



Designation: F1741 – 22

Standard Practice for Installation of Machine Spiral Wound Poly (Vinyl Chloride) (PVC) Liner Pipe for Rehabilitation of Existing Sewers and Conduits¹

This standard is issued under the fixed designation F1741; the number immediately following the designation indicates the year of original adoption or, in the case of revision, the year of last revision. A number in parentheses indicates the year of last reapproval. A superscript epsilon (ϵ) indicates an editorial change since the last revision or reapproval.

1. Scope*

1.1 This practice describes the procedures for the rehabilitation of sewer lines and conduits for existing pipelines 6 to 180 in. in diameter by the insertion of a machine-made field-fabricated spiral wound liner pipe into the existing pipeline using a winding machine which remains stationary in the insertion pit or, alternatively, which travels along the interior of the existing pipeline. These rehabilitation processes can be used in a variety of gravity applications such as sanitary sewers, storm sewers, culverts, and process piping.

1.1.1 When using stationary installation equipment for existing pipelines 6 to 48 in., after insertion, the spiral wound liner pipe is expanded until it presses against the interior surface of the existing pipeline. Alternatively, for existing pipelines 6 to 108 in. in diameter, the spiral wound liner pipe is inserted as a fixed diameter into the existing pipeline and is not expanded, and the annular space between the spiral wound liner pipe and the existing pipe is grouted.

1.1.2 When using the traveling installation equipment for existing pipelines 6 to 180 in. the spiral wound liner pipe is installed in contact with the interior surface of the existing pipeline to form a close fit liner, except in the corners of rectangular pipes or where obstructions or offsets occur. Alternatively, for existing pipelines 6 to 180 in. in diameter and for similar sized existing non circular pipelines such as arched or oval or rectangular shapes, the spiral wound liner is installed as a fixed diameter into the exiting pipeline to form a non-close fit liner and the annular space between the spiral wound liner pipe and the existing pipe is grouted.

1.2 The values stated in inch-pound units are to be regarded as standard. The values given in parentheses are mathematical conversions to SI units that are provided for information only and are not considered standard.

¹ This practice is under the jurisdiction of ASTM Committee F17 on Plastic Piping Systems and is the direct responsibility of Subcommittee F17.67 on Trenchless Plastic Pipeline Technology.

Current edition approved Nov. 15, 2022. Published December 2022. Originally approved in 1996. Last previous edition approved in 2018 as F1741–18. DOI: 10.1520/F1741-22.

1.3 *This standard does not purport to address all of the safety concerns, if any, associated with its use. It is the responsibility of the user of this standard to establish appropriate safety, health, and environmental practices and determine the applicability of regulatory limitations prior to use.*

Particular attention is drawn to those safety regulations and requirements involving entering into and working in confined spaces.

1.4 *This international standard was developed in accordance with internationally recognized principles on standardization established in the Decision on Principles for the Development of International Standards, Guides and Recommendations issued by the World Trade Organization Technical Barriers to Trade (TBT) Committee.*

2. Referenced Documents

2.1 *ASTM Standards:*²

[C39/C39M Test Method for Compressive Strength of Cylindrical Concrete Specimens](#)

[C109/C109M Test Method for Compressive Strength of Hydraulic Cement Mortars \(Using 2-in. or \[50 mm\] Cube Specimens\)](#)

[C495 Test Method for Compressive Strength of Lightweight Insulating Concrete](#)

[C1920 Practice for Cleaning of Vitrified Clay Sanitary Sewer Pipelines](#)

[D883 Terminology Relating to Plastics](#)

[D1600 Terminology for Abbreviated Terms Relating to Plastics](#)

[F412 Terminology Relating to Plastic Piping Systems](#)

[F1417 Practice for Installation Acceptance of Plastic Non-pressure Sewer Lines Using Low-Pressure Air](#)

[F1697 Specification for Poly\(Vinyl Chloride\) \(PVC\) Profile Strip for Machine Spiral-Wound Liner Pipe Rehabilitation of Existing Sewers and Conduit](#)

² For referenced ASTM standards, visit the ASTM website, www.astm.org, or contact ASTM Customer Service at service@astm.org. For *Annual Book of ASTM Standards* volume information, refer to the standard's Document Summary page on the ASTM website.

*A Summary of Changes section appears at the end of this standard

2.2 *Uni-Bell Standard:*

UNI-B-5-89 Recommended Practice for the Installation of PVC Sewer Pipe³

3. Terminology

3.1 *General*—Definitions are in accordance with Terminologies D883 and F412. Abbreviations are in accordance with Terminology D1600, unless otherwise indicated.

3.2 *Definitions of Terms Specific to This Standard:*

3.2.1 *extruded PVC profile strip*—a product available in various widths, consisting of a smooth inside surface and a ribbed outer surface with mechanically locked male and female edges which are self interlocking, or separate locking strips which serve the same purpose Type A and Type B are different profiles and are installed by different installation methods. See Fig. 1 and Table 1 for Type A and Fig. 2 and Table 2 for Type B. See Fig. 1 and Fig. 3 for installation method for Type A and Fig. 2 and Fig. 4 for installation method for Type B.

3.2.2 *insertion point*—an existing manhole, existing access shaft, or excavated pit that serves as the point where a winding machine field fabricates the spiral wound liner pipe and simultaneously inserts the spiral wound liner pipe into the existing pipeline.

3.2.3 *non-circular pipe*—arched, oval or rectangular or a combination thereof.

3.2.4 *production run*—a continuous extrusion of a given profile type.

3.2.5 *spiral wound liner pipe*—a product field fabricated from extruded PVC profile strip to a round shape, or noncircular shape, such as arched or oval or rectangular. (See Fig. 5.)

3.2.6 *steel reinforcement*— a shaped steel strip or clip inserted into the inside of the PVC profile to provide additional reinforcement and stiffening. (See Fig. 3 and Fig. 4.)

3.2.7 *termination point*—an existing manhole, existing access shaft, or an excavated pit that serves as the point of exit of the spiral wound liner pipe from the existing pipe.

4. Significance and Use

4.1 This practice is for use by designers and specifiers, regulatory agencies, owners, and inspection organizations who are involved in the rehabilitation of non-pressure sewers and conduits. Modifications may be required for specific job conditions.

5. Materials

5.1 The extruded profile strip used for the field fabrication of spiral wound liner pipe shall be in accordance with Specification F1697.

5.2 The profile strip should be coiled onto a reel in a continuous length for storage and shipping to the job site. Handling and storage should be in accordance with the manufacturer’s published recommendations.

5.3 The adhesive or sealants, or both, used with the male and female mechanical locking elements should be compatible with the PVC compound and the spiral wound liner pipe process so as not to affect the properties of the spiral wound finished liner pipe.

5.4 The steel reinforcing strips shall be used to reinforce the extruded PVC profile strip, where the design conditions requires additional stiffness, such as for non-circular shaped pipes.

6. Installation Recommendations

6.1 *Cleaning and Inspection:*

6.1.1 Prior to entering access areas such as manholes and performing inspection or cleaning operations, an evaluation of the atmosphere to determine the presence of toxic or flammable vapors or lack of oxygen must be undertaken in accordance with local, state, or federal safety regulations.

6.1.2 *Cleaning of Pipeline*—Internal debris shall be removed from the existing pipeline. Non-pressure gravity pipes shall be cleaned with hydraulically powered equipment, high-velocity jet cleaners, or mechanically powered equipment in accordance with manufacturers guidelines, Practice C1920, for VCP pipe or NASSCO recommended specifications, as applicable.

³ Available from Uni-Bell, 2655 Villa Creek Drive, Suite 155, Dallas TX 75234.

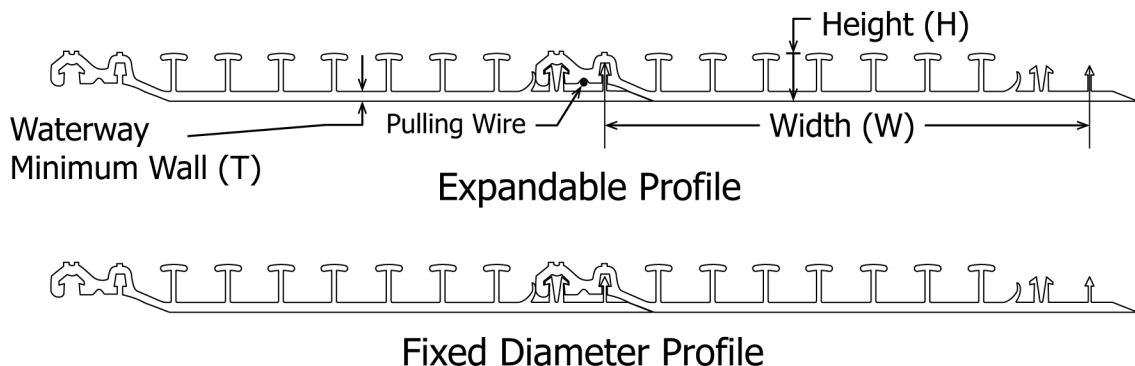

NOTE 1—For values of width, height, and waterway minimum wall, see Table 1.

FIG. 1 Type A-Typical PVC Profile Strip

TABLE 1 Type A Typical Profile Strip Moments of Inertia and Stiffness Factors

Profile Type ^{AB}	Moment of Inertia, <i>I</i>		Depth to Neutral Axis, \bar{y}		Minimum Height, <i>H</i>		Profile Area		Minimum Stiffness Factor, <i>EI</i> ^C	
	in. ⁴ /in.	(mm ⁴ /m)	in.	(mm)	in.	(mm)	in. ² /in.	(mm ² /mm)	in. ³ ·lbf/in. ²	(MPa·mm ³)
1	0.00047	(7.70)	0.077	(1.98)	0.216	(5.5)	0.118	(3.00)	188.0	(21.2 × 10 ³)
2	0.00140	(23.00)	0.130	(3.30)	0.314	(8.0)	0.146	(3.70)	561	(63.4 × 10 ³)
3	0.00537	(88.00)	0.206	(5.24)	0.511	(13.0)	0.205	(5.20)	2148	(242.7 × 10 ³)
4	0.00386	(63.30)	0.200	(5.08)	0.480	(12.2)	0.125	(3.18)	1600.0	(180.8 × 10 ³)
5	0.00400	(65.50)	0.180	(4.57)	0.488	(12.4)	0.125	(3.18)	1600.0	(180.8 × 10 ³)
6	0.00400	(65.50)	0.180	(4.57)	0.488	(12.4)	0.125	(3.18)	1600.0	(180.8 × 10 ³)

^AOther profiles, possibly using supplementary stiffener elements, may be available. Consult the manufacturer.

^BThe spacing of the ribs may vary for each profile type.

^CStiffness factors listed are the minimum values that will be provided by the manufacturer for the given profile type.

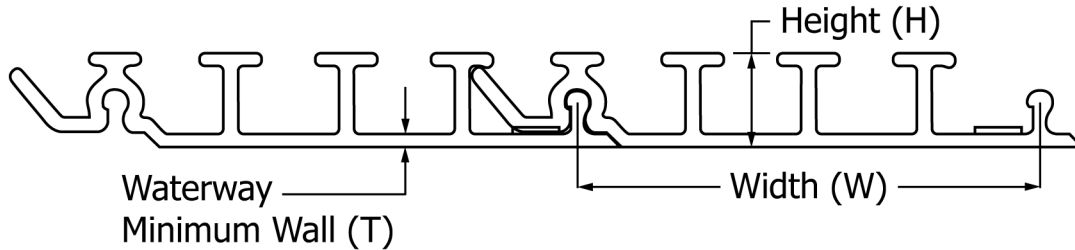

FIG. 2 Type B-Typical PVC Profile Strip

TABLE 2 Type B Typical Profile Strip Moments of Inertia and Stiffness Factors

Profile Type	Moment of Inertia, <i>I</i>		Depth to Neutral Axis, \bar{y}		Minimum Height, <i>H</i>		Profile Area		Minimum Stiffness Factor, <i>EI</i>	
	in. ⁴ /in.	(mm ⁴ /m)	in.	(mm)	in.	(mm)	in. ² /in.	(mm ² /mm)	in. ³ ·lbf/in. ²	(MPa·mm ³)
1	0.00106	(17.43)	...	(...)	0.319	(8.10)	0.132	(3.36)	362.5	40955
2	0.00218	(35.80)	0.26	(6.56)	0.422	(10.71)	0.150	(3.80)	745.0	84127
3	0.00571	(93.58)	0.58	(14.67)	0.578	(14.67)	0.227	(5.76)	1946.3	219900
4	0.01165	(190.92)	0.76	(19.35)	0.762	(19.35)	0.290	(7.36)	3971.0	448656
5	0.04142	(678.68)	1.12	(28.53)	1.123	(28.53)	0.463	(11.75)	14116.0	1594900
6	0.00444	(72.78)	0.56	(14.22)	0.560	(14.22)	0.187	(4.76)	1513.8	171042

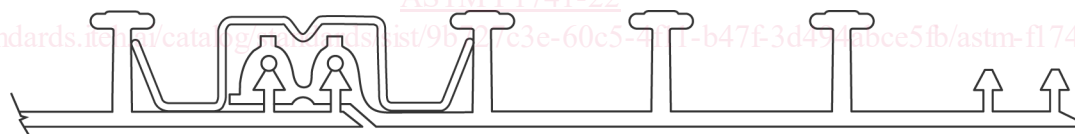

FIG. 3 Shaped Steel Reinforcing Strip Type A

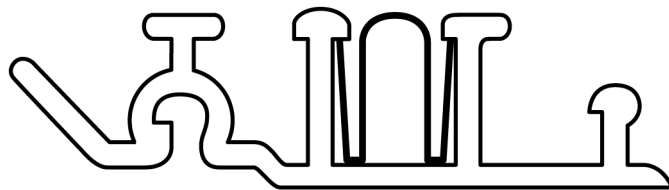

FIG. 4 Shaped Steel Reinforcing Strip Type B

6.1.3 *Inspection of Pipelines*—Inspection of pipelines should be performed by experienced personnel trained in locating breaks, obstacles, and service connections by closed-circuit television or by direct visual inspection. The interior of the pipeline should be carefully inspected to determine the location of any conditions that may prevent proper installation of the spiral wound liner pipe, such as protruding service taps, collapsed or crushed pipe, out-of-roundness, significant line

sags, and deflected joints. These conditions should be noted and corrected, if necessary, prior to installation.

6.1.4 *Line Obstructions*—The existing pipeline should be clear of obstructions that will prevent the proper insertion, and expansion if required, of the spiral wound liner pipe. Obstructions could include dropped or offset joints of more than 12.5 % of inside pipe diameter, service connections that protrude into the pipe more than 12.5 % of the inside pipe diameter or 1 in. (25 mm), whichever is less; and other obstructions in cross-sectional area of more than 16 % based on the inside diameter of the existing pipe. If inspection reveals an obstruction that cannot be removed by conventional equipment, then a point repair excavation should be made to uncover and remove or repair the obstruction. The angle of any bend along the pipeline that can be negotiated by the spiral wound liner pipe depends on a combination of factors such as the condition of the existing pipe, the location of the bend within the pipeline, and whether there are multiple bends. For

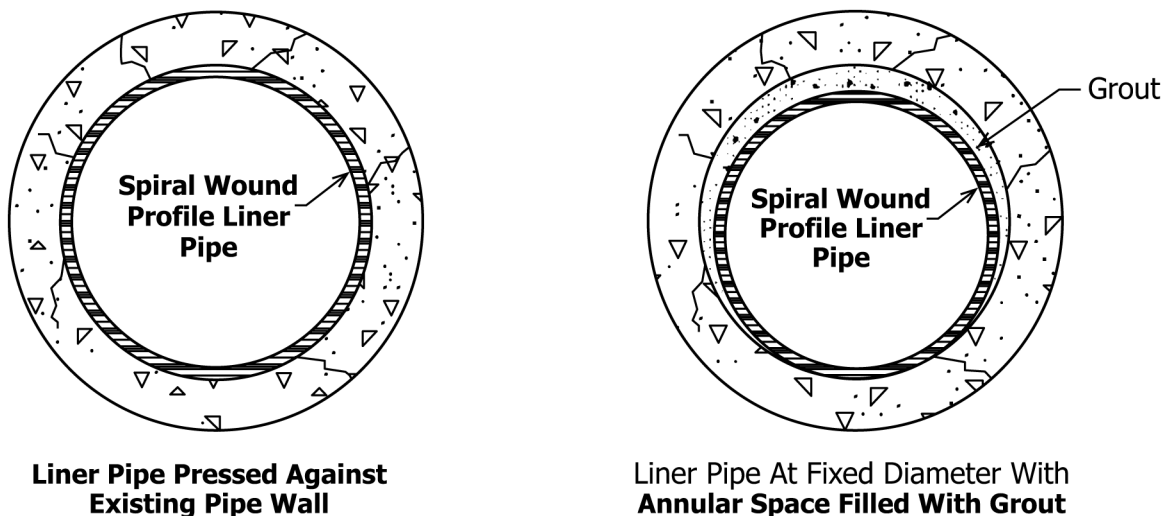

FIG. 5 Typical Spiral Wound Liner Pipe

a determination of whether a given bend can be accommodated, or whether access will be required for termination and start of a new insertion, consult the supplier of the liner material. Depending on the method of installation used, insertion and expansion, or fixed diameter, some changes in pipe size along the insertion length of the spiral wound liner pipe can be accommodated, and it is recommended that the spiral wound liner pipe material supplier be contacted.

6.2 *Bypassing*—The spiral wound liner pipe process does not require a dry pipeline and can be installed with some flow in the existing pipe or lateral connections, or both. If necessary, the bypass should be made by plugging the line at a point upstream of the pipe to be reconstructed and pumping the flow to a downstream point or adjacent system. The pump and bypass lines should be of adequate capacity and size to handle any extreme flows expected during the installation period.

6.2.1 Under certain conditions, part or all of the installation may be carried out with some flow in the existing pipeline or service connections, or both.

6.3 *Pipe Liner Fabrication and Insertion Using Stationary Installation Equipment:*

6.3.1 A winding machine should be placed in the insertion pit and oriented so that the liner pipe can be spirally wound and inserted (rotated and pushed) directly into the existing pipeline. A reel of extruded PVC profile strip should be positioned near the insertion point. The initial winding process begins with the profile strip being fed into the winding machine, forming the profile strip into the required spiral wound liner pipe diameter, which is simultaneously rotated and pushed along the existing pipeline for its full length to the termination point. As the profile strip is formed into a spiral, wound liner pipe in the winding machine, the required sealant or adhesive, or both unless already in place, shall be placed within the primary and secondary locks of the locking configuration at the edge of the profile strip, and wire is placed between the primary and secondary locks of the locking configuration when the spiral wound liner pipe is to be expanded (see Fig. 6 and Fig. 7).

6.3.2 When the spiral wound liner pipe is to be expanded as shown in Fig. 6, the end of the spiral wound liner pipe at the termination point should be torsionally restrained. A specific length of the inserted spiral wound liner pipe is released at the termination point by pulling the wire out of the expandable

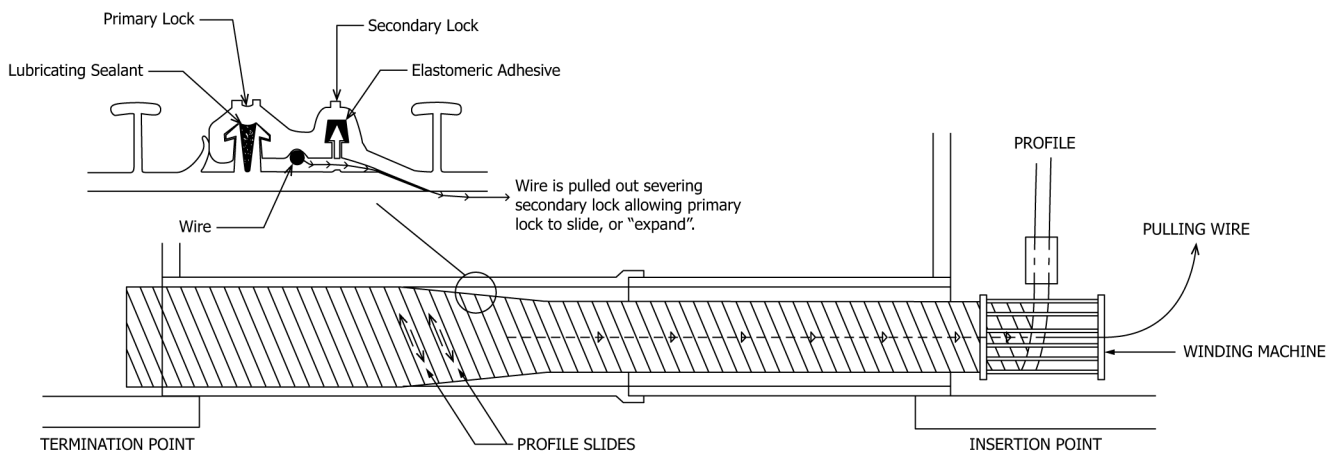

FIG. 6 Insertion of Expandable Spiral Wound Liner

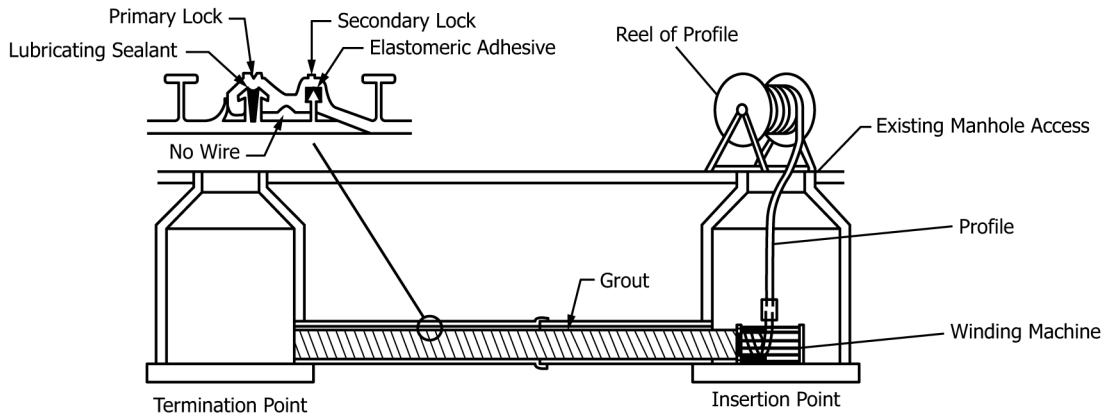

FIG. 7 Insertion of Fixed-Diameter Spiral Wound Liner

interlocked joint, thereby severing the secondary lock (see Fig. 6), thus releasing the profile strip to slide freely along the primary rock when a torque is applied to the inserted spiral wound liner pipe. The winding operation should be recommenced, thereby creating a torque which is applied to the released end, thus causing a radial growth or expansion over the released length of the spiral wound liner pipe. The initial radial growth should be permitted to continue until the released end of the spiral wound liner pipe is pressed against the existing pipeline (see Fig. 6), thus halting radially growth and torsionally restraining the spiral wound liner pipe. Subsequent secondary lock release and winding should continue until the spiral wound liner pipe is pressed against the full length of the existing pipe. The annular space between the expanded spiral wound liner pipe and the existing pipeline should be sealed at the ends with a sealing material that is compatible with the spiral wound liner pipe material.

6.4 Pipe Liner Fabrication Using Traveling Installation Equipment:

6.4.1 A traveling winding machine should be placed in the insertion point and oriented so that the winding machine can travel directly into the existing pipeline. A reel of extruded PVC profile strip should be positioned near the insertion point. The winding process begins with the profile strip being fed into the winding machine. The traveling winding machine then simultaneously rotates and moves along the existing pipeline for its full length to the termination point, forming the profile

strip into the required spiral wound liner pipe diameter or rectangular or non-circular pipeline shape, such as arched or oval. As the profile strip is formed into a spiral wound liner pipe in the winding machine, the sealant or adhesive, or both unless already in place, shall be placed within the primary lock of the locking configuration at the edge of the profile strip. (See Fig. 8 and Fig. 9)

6.4.2 When the spiral wound liner pipe is to be pressed against the existing pipe wall the traveling winding machine should be adjusted to apply the spiral wound liner pipe directly against the existing pipe wall. As the profile strip is formed into a spiral wound liner pipe in the winding machine, the sealant or adhesive, or both unless already in place, shall be placed within the primary lock of the locking configuration at the edge of the profile strip. The space between the spiral wound liner pipe and the existing pipeline should be sealed at the ends with a sealing material that is compatible with the spiral wound liner pipe material.

6.5 Grouting:

6.5.1 When the spiral wound liner pipe is inserted into the existing pipeline and grouted, the following procedure should be followed. The annular space between the expanded spiral wound liner pipe and the existing pipeline should be sealed at the ends with a sealing material that is compatible with the spiral wound liner pipe material. Grout is then injected throughout the annular space in a variety of ways such as through openings in the end seals, at reconnected service

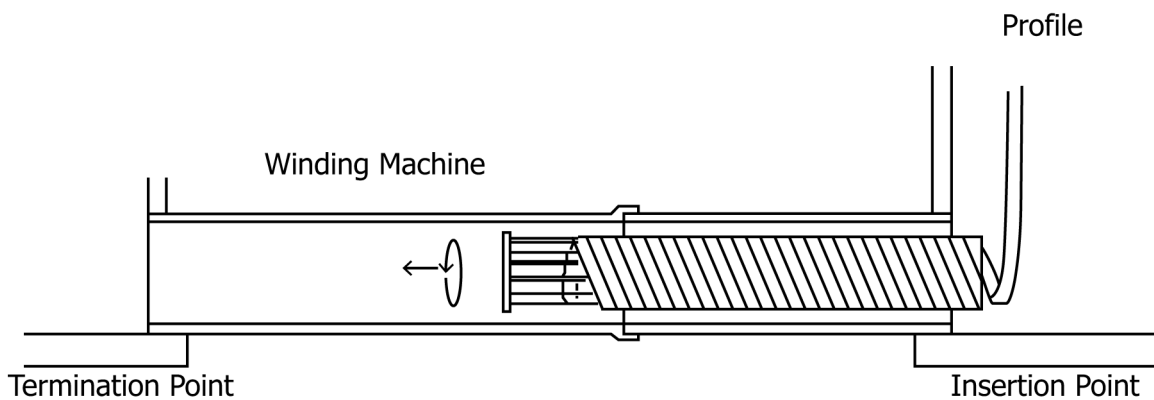

FIG. 8 Insertion of Fixed-Diameter Spiral Wound Liner Using Traveling Installation Equipment