



Designation: D3609 – 22

Standard Practice for Calibration Techniques Using Permeation Tubes¹

This standard is issued under the fixed designation D3609; the number immediately following the designation indicates the year of original adoption or, in the case of revision, the year of last revision. A number in parentheses indicates the year of last reapproval. A superscript epsilon (ϵ) indicates an editorial change since the last revision or reapproval.

1. Scope

1.1 This practice describes a means for using permeation tubes for dynamically calibrating instruments, analyzers, and analytical procedures used in measuring concentrations of gases or vapors in atmospheres (1, 2).²

1.2 Typical materials that may be sealed in permeation tubes include: sulfur dioxide, nitrogen dioxide, hydrogen sulfide, chlorine, ammonia, propane, and butane (1).

1.3 The values stated in SI units are to be regarded as standard.

1.4 *This standard does not purport to address all of the safety concerns, if any, associated with its use. It is the responsibility of the user of this standard to establish appropriate safety, health, and environmental practices and determine the applicability of regulatory limitations prior to use.*

1.5 *This international standard was developed in accordance with internationally recognized principles on standardization established in the Decision on Principles for the Development of International Standards, Guides and Recommendations issued by the World Trade Organization Technical Barriers to Trade (TBT) Committee.*

2. Referenced Documents

2.1 *ASTM Standards:*³

D1356 Terminology Relating to Sampling and Analysis of Atmospheres

D3195 Practice for Rotameter Calibration

E1 Specification for ASTM Liquid-in-Glass Thermometers

E2251 Specification for Liquid-in-Glass ASTM Thermometers with Low-Hazard Precision Liquids

3. Terminology

3.1 *Definitions*—Refer to Terminology **D1356**.

¹ This practice is under the jurisdiction of ASTM Committee D22 on Air Quality and is the direct responsibility of Subcommittee D22.01 on Quality Control.

Current edition approved Nov. 1, 2022. Published December 2022. Originally approved in 1977. Last previous edition approved in 2014 as D3609 – 00 (2014). DOI: 10.1520/D3609-22.

² The boldface numbers in parentheses refer to a list of references at the end of this standard.

³ For referenced ASTM standards, visit the ASTM website, www.astm.org, or contact ASTM Customer Service at service@astm.org. For *Annual Book of ASTM Standards* volume information, refer to the standard's Document Summary page on the ASTM website.

4. Summary of Practice

4.1 A liquefiable gas, when enclosed in an inert plastic tube, escapes by permeating the tubing wall at a constant, reproducible, temperature-dependent rate.

4.2 Permeation tubes are calibrated gravimetrically, with the weight loss of the tube equated to the weight of the escaping material.

4.3 Permeation tubes are held at constant temperature in a carrier-gas stream of dry air or nitrogen to produce a gas concentration dependent on the permeation rate and the flow of the carrier gas.

5. Significance and Use

5.1 Most analytical methods used in air pollutant measurements are comparative in nature and require calibration or standardization, or both, often with known blends of the gas of interest. Since many of the important air pollutants are reactive and unstable, it is difficult to store them as standard mixtures of known concentration for extended calibration purposes. An alternative is to prepare dynamically standard blends as required. This procedure is simplified if a constant source of the gas of interest can be provided. Permeation tubes provide this constant source, if properly calibrated and if maintained at constant temperature. Permeation tubes have been specified as reference calibration sources, for certain analytical procedures, by the Environmental Protection Agency (3).

6. Interferences and Precautions

6.1 Permeation tubes are essentially devices to provide a constant rate of emission of a specific gaseous substance over period of time. They consist of a two-phase (gas-liquid) system to maintain a constant vapor pressure (at constant temperature) which is the driving force for emission of the gas through a semipermeable membrane (tube walls). They can be expected to maintain a constant emission rate that is temperature dependent as long as a significant amount of liquid is present in the device. The liquid shall be pure, else its composition may change during the life time of the tube, due to differential evaporation, with consequent vapor pressure changes. Care must also be exercised that the diffusion membrane (tube walls) is not damaged or altered during use. The contents of permeation tubes are under relatively high pressure. Accordingly, there is the possibility of violent rupture of tube

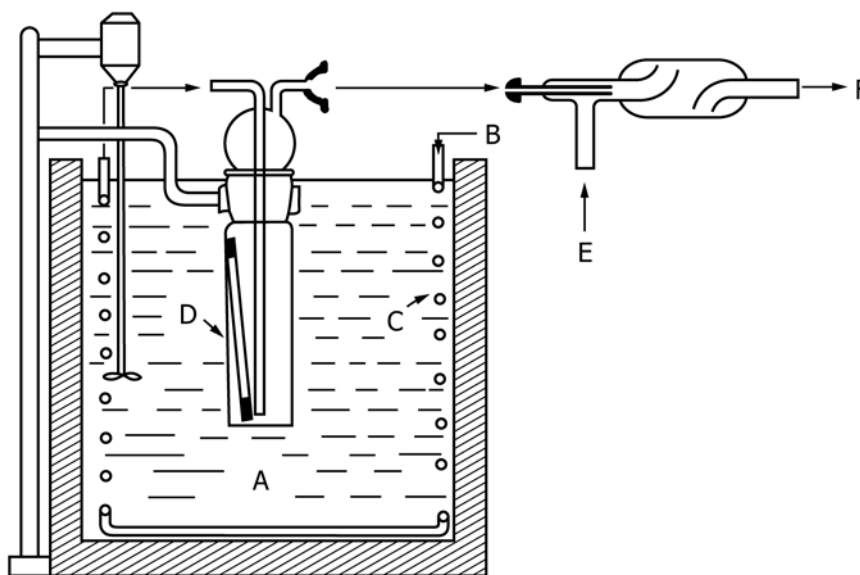

A—Thermostated water bath with thermometer
 B—Metered pure air inlet
 C—Air temperature equilibration coil
 D—Permeation tube
 E—Metered dilution air inlet
 F—Air mixture outlet

NOTE 1—This system has the advantage of smaller uncertainty of the temperature of the permeation tube.

FIG. 1 Optional System for Laboratory Use of a Permeation Tube

walls under high temperature exposure. Permeation rates have temperature coefficients up to 10 % per degree Celsius. When temperature coefficients are large, above 3 % per degree Celsius, stringent temperature control is required. Furthermore permeation tubes exhibit temperature hysteresis so that they must be temperature equilibrated from 2 to 24 h before use, depending upon the temperature differential between storage and use (4). It is important that permeation tubes are filled with anhydrous constituents of high purity. They shall be handled with care to minimize contact with moisture, oil, and foreign substances.

6.2 Sulfur dioxide (SO₂) permeation tubes are relatively insensitive to interferences.

6.3 Nitrogen dioxide (NO₂) permeation tubes are sensitive to moisture, hence they should be stored in dry atmospheres and used with relatively dry carrier gases (<10 % relative humidity). Permeation of moisture into the contents of a tube may damage the walls and also cause progressive decreases in the permeation rate. Moisture incorporated in the contents during manufacture can cause the same effect (4).

6.4 Hydrogen sulfide (H₂S) permeation tubes may turn white during use in the presence of oxygen because of inverse permeation and formation of colloidal sulfur. This phenomenon may affect the permeation rate, if severe, hence is a reason for recalibration. However, in an inert gas stream, the tubes are relatively stable.

6.5 Materials of construction shall be compatible with the contents of the tube. For instance, some fluorocarbons may cause FEP tubes to swell and possibly to rupture.

7. Apparatus

7.1 *Permeation Tube* sized in accordance with and calibrated to concentrations needed or expected for the analysis method. The user should check calibration as described in Section 9.1.

7.2 *Flow and Temperature Control System*—Prepare or purchase a system that will dry the carrier gas, and control and measure its flow as it passes over the permeation tube that is being held at constant temperature. If lower concentrations are desired, a second gas supply (diluent gas) with its control and measurement devices may be needed to mix with the gas from the permeation tube chamber. Equipment of this kind is available commercially. A typical system contains a thermoelectrically temperature-controlled permeation tube chamber with temperature control within ± 0.1 °C over the range from 15 °C to 35 °C. Such equipment is well suited to field usage.

7.3 A typical system for laboratory use that can be assembled from readily available parts is shown schematically in Fig. 1. The parts required are described in the following subsections.

7.3.1 *Flowmeters*—Several, sufficient to cover the range from 0 L/min to 15 L/min, calibrated by Practice D3195.

7.3.2 *Copper Tubing*—Approximately 1 m long [3 ft] by 6.25 mm [0.25 in.] in outside diameter for use as a heat exchanger in the water bath.

7.3.3 *Ball Joints (Ungreased) and Tubing*, for the necessary connections. Butt seals may also be used made with inert materials such as polyethylene.

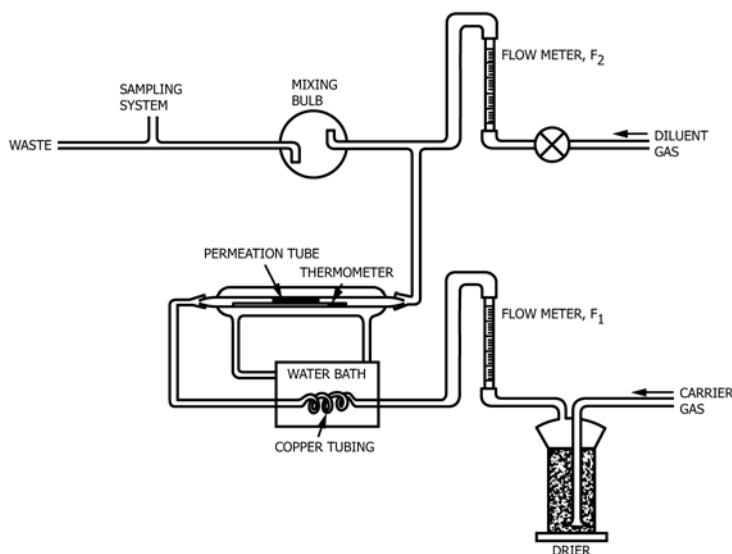

NOTE 1—This system is constructed from readily available laboratory equipment.

NOTE 2—**Warning**—If the room temperature is significantly different from that of the water bath, a small difference in temperature between the bath and the condenser containing the permeation tube can exist. In this event, the temperature indicated by the thermometer in the condenser should be used as that of the permeation tube, rather than that of the water bath.

FIG. 2 Typical System for Laboratory Use

7.3.4 *Mixing Bulb*, to ensure adequate mixing of the permeated gas and the diluent gas stream. A Kjeldahl trap is recommended.

7.3.5 *Long Condenser*, with large bore in which a thermometer and a permeation tube can be inserted.

7.3.6 *Temperature Controlled Water Bath*—About 8-L [2-gal] capacity, capable of ± 0.1 °C or better water temperature control, with a variable temperature control range from about 15 °C to 35 °C, preferably equipped with a positive displacement type recirculating pump with at least 1-L/min liquid flow rate to supply water to the condenser.

7.3.7 *Thermometer*, ASTM No. 91C (see Specification E1), ASTM No. S91C (see Specification E2251), or equivalent, calibrated to ± 0.1 °C.

7.3.8 *Barometer*.

7.4 An alternate system is shown in Fig. 2. It has the advantage of lower uncertainty of the temperature of the permeation tube. The required parts are described in the figure.

8. Reagents and Materials

8.1 *Carrier Gas or Diluent Gas for Flow Over Permeation Tube*—Cylinder of dry nitrogen or pure, dry air, or purified room air (charcoal and drying agent—inert air mover).

8.1.1 *Drier*, indicating type and should be discarded when color changes.

8.2 *Diluent Gas for Blending with Carrier Stream Downstream from Permeation Tube*, free from impurities that would consume test substances.

9. Calibration of Permeation Tubes

9.1 Permeation tubes may be calibrated gravimetrically by measurement of the weight loss occurring during storage at a constant temperature (4, 5). A slow stream of dry air or nitrogen shall flow over the tube during the calibration period.

A specially constructed constant temperature chamber may be used or, if more convenient, the weight loss occurring during use of the tube in the actual flow system (7.2 and 7.3) can be measured. In the latter case, place the tube in its chamber (condenser) and run the system as described in Section 10. Remove the tube at 24-h intervals and weigh on a semimicro analytical balance. Handle the tube with gloves or forceps to minimize pickup of moisture or grease. Remove the tube for only the minimum time required for the weighing. Furthermore, it is advisable to conduct the weighings when the relative humidity does not exceed 50 %. Record the weighings to the nearest 0.01 mg. Because NO_2 permeation tubes may pick up moisture on exposure to air, they may need to be weighed on a rigid time schedule to reproduce any mass changes as a result of this cause (5). Repeat the weighing operation at scheduled intervals and plot the gross weight against elapsed time in minutes. The slope expressed as micrograms per minute represents the output of the tube. The total time usually needed to calibrate at a given temperature should not be less than five days. Alternatively, linear regression analysis may be used to determine the permeation rate. Record measurements of permeation rates at several temperatures and plot the results on semilog paper to obtain the output at any temperature within the calibration range. As a precaution against defective seals, check the first calibration after approximately two weeks; it should be within 2 % of the initial value. If 2 % cannot be achieved, reject the tube.

NOTE 1—While permeation tube life may be extended by refrigerated storage, it is suggested to store tubes at operating (or room) temperature to avoid excessive preconditioning time.

9.2 The frequency of recalibration will depend upon type of permeation tube, the quality of its construction and the care exercised in its use.