



Designation: ~~C167—18~~ C167 – 22

# Standard Test Methods for Thickness and Density of Blanket or Batt Thermal Insulations<sup>1</sup>

This standard is issued under the fixed designation C167; the number immediately following the designation indicates the year of original adoption or, in the case of revision, the year of last revision. A number in parentheses indicates the year of last reapproval. A superscript epsilon ( $\epsilon$ ) indicates an editorial change since the last revision or reapproval.

*This standard has been approved for use by agencies of the U.S. Department of Defense.*

## 1. Scope

1.1 These test methods cover the determination of thickness and density of flexible, felted, or woven thermal insulating blankets, rolls, or batts composed of fibrous materials, with or without surface covering or reinforcement.

1.2 The values stated in inch-pound units are to be regarded as standard. The values given in parentheses are mathematical conversions to SI units that are provided for information only and are not considered standard.

1.3 *This standard does not purport to address all of the safety concerns, if any, associated with its use. It is the responsibility of the user of this standard to establish appropriate safety, health, and environmental practices and determine the applicability of regulatory limitations prior to use.*

1.4 *This international standard was developed in accordance with internationally recognized principles on standardization established in the Decision on Principles for the Development of International Standards, Guides and Recommendations issued by the World Trade Organization Technical Barriers to Trade (TBT) Committee.*

## 2. Referenced Documents

2.1 *ASTM Standards*:<sup>2</sup> <https://standards.iteh.ai/catalog/standards/sist/6b21fbd6-deb0-4626-bcfd-31cb6aeb405b/astm-c167-22>

[C168 Terminology Relating to Thermal Insulation](#)

[E2935 Practice for Evaluating Equivalence of Two Testing Processes](#)

## 3. Terminology

3.1 *Definitions*—Terminology [C168](#) shall be considered as applicable to the terms used in these test methods.

3.2 *Definitions of Terms Specific to This Standard:*

3.2.1 *package*—an individually wrapped group or bag of batts or a single roll of thermal insulation material.

## 4. Significance and Use

4.1 Proper measurements of thickness and density of blanket or batt insulations are essential for determining thermal insulation properties. For a particular batt or blanket product, thickness and density are usually directly related to thermal insulating value.

<sup>1</sup> These test methods are under the jurisdiction of ASTM Committee [C16](#) on Thermal Insulation and are the direct responsibility of Subcommittee [C16.32](#) on Mechanical Properties.

Current edition approved Nov. 1, 2018; Nov. 1, 2022. Published November 2018/December 2022. Originally approved in 1941. Last previous edition approved in 2015/2018 as ~~C167—15~~ C167 – 18. DOI: [10.1520/C0167-18](https://doi.org/10.1520/C0167-18); [10.1520/C0167-22](https://doi.org/10.1520/C0167-22).

<sup>2</sup> For referenced ASTM standards, visit the ASTM website, [www.astm.org](http://www.astm.org), or contact ASTM Customer Service at [service@astm.org](mailto:service@astm.org). For *Annual Book of ASTM Standards* volume information, refer to the standard's Document Summary page on the ASTM website.

4.2 These test methods are of significant value in manufacturing quality control, to ensure that claimed insulation values of products are maintained.

**5. Apparatus**

5.1 *Depth Gauge*, of the type shown in Fig. 1. The disk shall be fabricated of a suitable plastic material. The disk shall have a mass of  $9.3 \pm 0.3$  grams and shall exert a pressure of  $0.4 \text{ lbf/ft}^2$  ( $20 \text{ Pa}$ ). The disk shall be 3-in.  $\pm 0.08$ -in. ( $76 \text{ mm} \pm 2\text{mm}$ ) in diameter. The disk shall be perpendicular to the pin at all times and shall have a friction device or thumb grip to secure the pin unless purposely moved. The pin shall be made at a maximum  $1/8$ -in. ( $3 \text{ mm}$ ) diameter. The pin shall be of sufficient length for the material to be measured.

5.2 *Steel rule*, graduated in 0.05-in. or 1-mm intervals.

5.3 *Scales*, of sufficient capacity and sensitivity to weigh the test specimen to an accuracy of  $\pm 0.5 \%$ .

5.4 An alternative thickness measurement technique is considered acceptable if the alternative method and depth gauge presented in 5.1 meet the means equivalency analysis as directed in Section 7 of Practice E2935. The equivalence limit of 0.2 in., a confidence level of 95 %, and minimum sample size of 50 shall be used in the equivalency analysis. The equivalence analysis must cover the range of thickness for which it will be used.

**6. Sampling**

6.1 A test sample shall consist of one representative roll or package of insulation.

6.2 *Sampling of Packages*—For packages which contain 20 or more batts, five batts shall be selected. For packages which contain less than 20 batts, either the three-batt or five-batt selection technique may be used. Batts which are folded in half shall count as two batts for purposes of choosing and employing the selection method.

6.2.1 *Three-Batt Method*—Select the center batt and the second batt in from each end of the package.

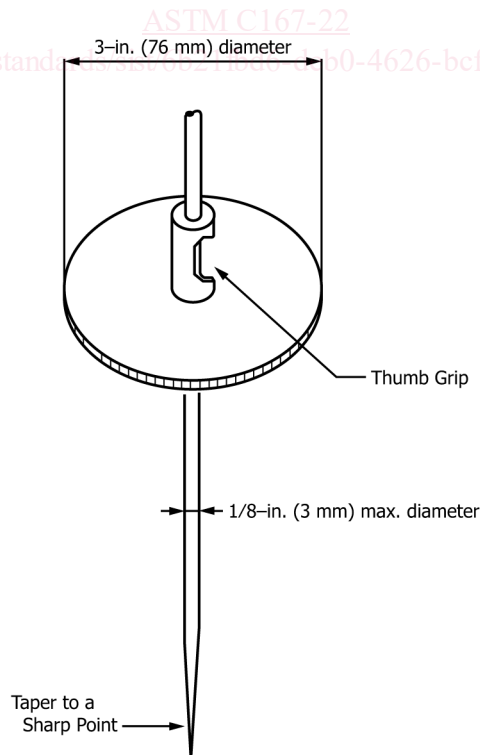

**FIG. 1 Depth Gauge for Thickness Measurements**

6.2.2 *Five-Batt Method*—Divide the package sequentially into five groups of batts as equal in number as possible. Select the first batt from each group. Be careful to select one and only one batt from the two end batts within the package.

6.2.3 Cut batts which are longer than 48 in. to  $48 \pm 0.25$  in. ( $122 \pm 0.63$  cm) in length.

6.3 *Sampling of Cut Rolls*—Five batts shall be cut of roll-width by  $48 \pm 0.25$  in. ( $122 \pm 0.63$  cm) in length.

6.3.1 Cut one batt from the center of the roll, two batts from the ends of the roll, and the fourth and fifth from the quarter points along the length. See Fig. 2.

6.3.2 For blankets wider than 24 in., cut each of the five batts  $24 \pm 0.25$  in. ( $61 \pm 0.63$  cm) wide by  $48 \pm 0.25$  in. ( $122 \pm 0.63$  cm) long.

6.4 *Sampling for Full Roll Method*—~~This method~~ Subsection 7.6 can be used is acceptable to use in place of 6.3 when the roll is wider than 24 in. (61 cm) or longer than 50 ft (16.4 m). ~~Prior to unrolling the material, weigh the entire roll to the nearest 0.25 pound (0.11 kg). Two methods may be used to obtain the full roll weight. The first method removes the insulation product from the packaging prior to weighing. The material will expand and may unroll slightly, care must be taken to ensure that the full roll is weighed accurately. The second method weighs the packaged insulation product, then weighs the packaging material only. The packaging material weight is subtracted from packaged product weight to obtain net material weight.~~

## 7. Procedure

7.1 *Expansion of Packages and Cut Roll*—Hold the first batt vertically off the floor by grasping it with both hands on its long dimension so that the lower edge is  $18 \pm 1$  in. ( $460 \pm 25$  mm) above a solid horizontal surface. Release the batt, allowing it to strike the surface. Repeat the above for a second time. Next, holding the batt by the other long edge, drop twice as above. Place the specimen on the flat, hard surface. Repeat the above for the remaining four specimens. Allow specimens to reach equilibrium by waiting at least 5 min before making thickness measurements within 1 in. (25 mm) in any direction of five points as indicated in Fig. 3.

# Document Preview

NOTE 1—If 23-in. (580-mm) wide samples are tested, use a quarter or half of that dimension to establish the test points.

NOTE 2—Some materials may require 4 h or more to reach equilibrium.

7.2 *Expansion of Full Roll*—Unroll the insulation. Flip the test roll over its entire length so the bottom surface is now on top. Next grasp one end and pull the material over itself until the original surface is again facing up. If there is insufficient room to pull the material over itself (less than twice the unrolled length), the material may be repositioned by sliding the partially pulled roll to the end of the testing space, and continue to pull the material over itself.

NOTE 3—Use 7.1 if sampling procedure in 6.3 is used.

7.3 *Measurement of Packages and Cut Roll*—Insert the pin of the thickness gauge vertically into the material at the first measuring point with a twisting motion until it contacts the hard surface beneath. Lower the disk until it lightly and uniformly contacts the specimen. An alternative procedure is to use a disk whose mass exerts a specified pressure of at least 0.4 lbf/ft<sup>2</sup> (20 Pa) on the specimen. With the gauge disk locked against the pin, lift the gauge unit from the test specimen. While holding the gauge in locked

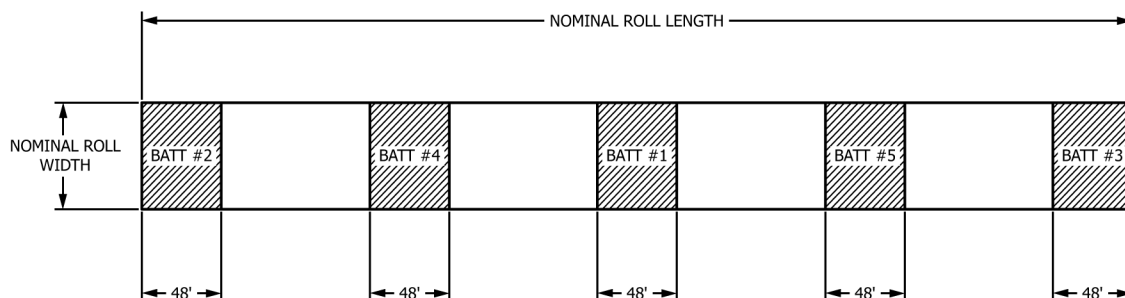
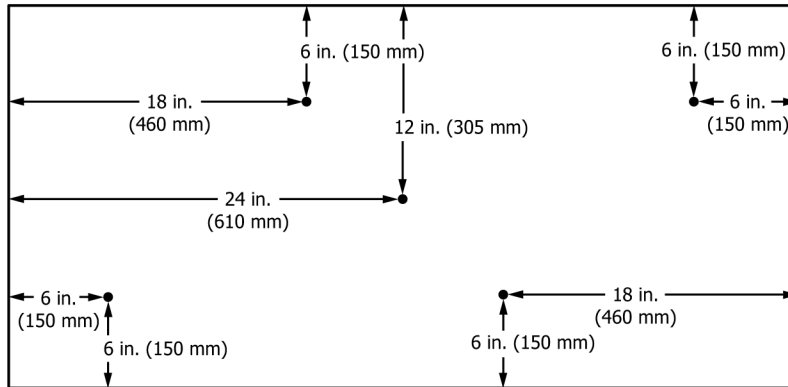

FIG. 2 Sampling of Cut Rolls

24 by 48 - in. Specimen



15 by 48 - in. Specimen

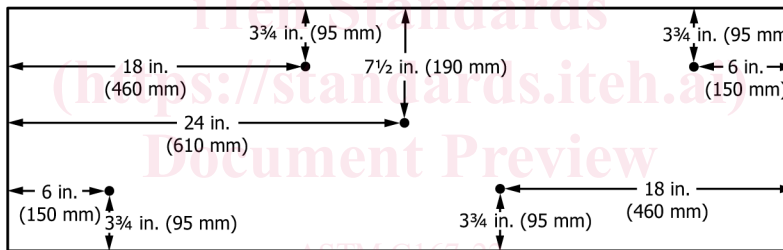

FIG. 3 Thickness Measurement Locations

<https://standards.iteh.ai/catalog/standards/sist/66211b06-dc00-4626-bcfd-31cb6aeb405b/astm-c167-22>

position, place the disk against the zero end of the rule with the pin projecting along the calibrated surface of the rule. Observe and record the reading at the pointed end of the pin to the nearest 0.05 in. (1 mm). Repeat the above for each of the remaining measuring points as shown in Fig. 3.

7.4 *Measurement of Full Roll*—Record the roll length to the nearest 1 in. (2.54) cm. Take measurements on each side of the roll. If the roll has been cut in half, take a third roll length measurement along the midpoint of the roll width. Record roll width at three locations to the nearest 0.125 in. (0.32) cm. Width measurements will be taken 10 ft (3.05) m from each end, and in the middle of the roll length. Using a pin gauge, record thickness to the nearest 0.05 in. (1 mm) as shown in Fig. 4. Refer to Section 7.3 for

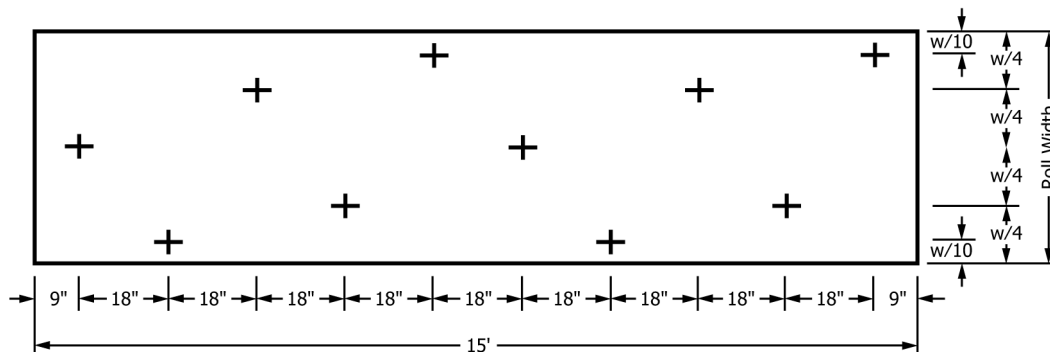

FIG. 4 Thickness Measurement Locations – Full Roll

use of pin gauge. Two 15 ft (4.57 m) long sections shall be measured. These sections shall be 10 (3.05 m) in from each end. A total of twenty thickness measurements will be taken for each roll.

NOTE 4—Use 7.4 if sampling procedure in 6.4 is used.

~~NOTE 4—Use 7.4 if sampling procedure in 6.4 is used.~~

7.5 Determination of Batt Weight—Determine the weight of each batt including the facer, if applicable, to a minimum precision of 0.5 g.

7.5.1 For batts received with a facer, determine the weight of the facer from a minimum of one additional batt not used in the sample selection. Determine the weight of the facer by carefully removing the facer with a sharp knife or similar tool. Ensure that all fibrous material is removed from the facer before determining facer weight.

7.5.1.1 The facer weight shall be used to determine the weight per unit area and density of the insulation in 8.2. Subtract the weight of the facer from the as-received weight (facer plus insulation) of the samples to determine the weight of the insulation.

7.6 Determination of Roll Weight—Prior to unrolling the material, weigh the entire roll including the facer, if applicable, to the nearest 0.2 lb (0.1 kg).

7.6.1 Two methods are acceptable for use to obtain the full roll weight.

7.6.1.1 The first method removes the insulation product from the packaging prior to weighing. The material will expand and potentially unroll slightly; care must be taken to ensure that the full roll is weighted accurately.

7.6.1.2 The second method weighs the packaged insulation product then weighs the packaging material only. The packaging material weight is subtracted from the weight of the packaged product to obtain the net thermal insulation weight.

7.6.2 For full rolls with facers. If the rolls are received with a facer, repeat the step in 7.5.1, and determine the weight of at least 4.0 ft<sup>2</sup> sections of the facer.

7.6.3 Use this weight to determine the weight of the entire roll facer. The facer weight shall be used to determine the weight per unit area and density of the insulation in 8.2.

## **8. Calculation**

8.1 Thickness—Take the average of the thickness measurements made in accordance with Section 7 as the thickness of the specimen.