



Designation: **D972—16** **D972 – 22**

Standard Test Method for Evaporation Loss of Lubricating Greases and Oils¹

This standard is issued under the fixed designation D972; the number immediately following the designation indicates the year of original adoption or, in the case of revision, the year of last revision. A number in parentheses indicates the year of last reapproval. A superscript epsilon (ϵ) indicates an editorial change since the last revision or reapproval.

This standard has been approved for use by agencies of the U.S. Department of Defense.

1. Scope*

1.1 This test method covers the determination of the loss in mass by evaporation of lubricating greases and oils for applications where evaporation loss is a factor. Evaporation loss data can be obtained at any temperature in the range from 100 °C to 150 °C (210 °F to 300 °F).

1.2 The values stated in SI units are to be regarded as standard.

1.2.1 *Exception*—The values given in parentheses are for information only.

1.3 *This standard does not purport to address all of the safety concerns, if any, associated with its use. It is the responsibility of the user of this standard to establish appropriate safety, health, and environmental practices and determine the applicability of regulatory limitations prior to use.*

1.4 *This international standard was developed in accordance with internationally recognized principles on standardization established in the Decision on Principles for the Development of International Standards, Guides and Recommendations issued by the World Trade Organization Technical Barriers to Trade (TBT) Committee.*

2. Referenced Documents

[ASTM D972-22](#)

<https://standards.iteh.ai/catalog/standards/sist/bfc06a75-4e6d-4a46-ae11-4495b8cbb9b7/astm-d972-22>

2.1 *ASTM Standards:*²

[A240/A240M Specification for Chromium and Chromium-Nickel Stainless Steel Plate, Sheet, and Strip for Pressure Vessels and for General Applications](#)

[D217 Test Methods for Cone Penetration of Lubricating Grease](#)

[D2595 Test Method for Evaporation Loss of Lubricating Greases Over Wide-Temperature Range](#)

[D4175 Terminology Relating to Petroleum Products, Liquid Fuels, and Lubricants](#)

[E2251 Specification for Liquid-in-Glass ASTM Thermometers with Low-Hazard Precision Liquids](#)

3. Terminology

3.1 *Definitions:*

3.1.1 For definitions of terms used in this test method, refer to Terminology [D4175](#).

3.1.2 *lubricating grease, n*—a semi-fluid to solid product of a thickener in a liquid lubricant.

¹ This test method is under the jurisdiction of ASTM Committee D02 on Petroleum Products, Liquid Fuels, and Lubricants and is the direct responsibility of Subcommittee D02.G0.03 on Physical Tests.

Current edition approved April 1, 2016/Dec. 1, 2022. Published May 2016/December 2022. Originally approved in 1948. Last previous edition approved in 2008/2016 as [D972—02 \(2008\):D972 – 16](#). DOI: [10.1520/D0972-16](#); [10.1520/D0972-22](#).

² For referenced ASTM standards, visit the ASTM website, www.astm.org, or contact ASTM Customer Service at service@astm.org. For *Annual Book of ASTM Standards* volume information, refer to the standard's Document Summary page on the ASTM website.

*A Summary of Changes section appears at the end of this standard

3.1.2.1 Discussion—

The dispersion of the thickener forms a two-phase system and immobilizes the liquid lubricant by surface tension and other physical forces. Other ingredients are commonly ~~D217~~ included to impart special properties.

3.1.3 *thickener, n*—in lubricating grease, a substance composed of finely divided particles dispersed in a liquid to form the product's structure.

3.1.3.1 Discussion—

Thickeners can be fibers (such as various metallic soaps) or plates or spheres (such as certain non-soap thickeners), which are insoluble or, at most, only very slightly soluble in the liquid lubricant. The general requirements are that the solid particles are extremely small, uniformly dispersed, and capable of forming a relatively stable, gel-like structure with the ~~D217~~ liquid lubricant.

4. Summary of Test Method

4.1 The weighed sample of lubricant in an evaporation cell is placed in a bath maintained at the desired test temperature. Heated air is passed over its surface for 22 h. The evaporation loss is calculated from the loss in mass of the sample.

5. Significance and Use

5.1 The loss of volatile materials from greases and oils can adversely effect the original performance characteristics of a lubricant and therefore could be a significant factor in evaluating a lubricant for a specific use. Such volatiles can also be considered contaminants in the environment in which the lubricant is to be used. Correlation between results from this test method and service performance has not been established.

5.2 The test can be run at any agreed upon temperature between 100 °C and 150 °C (210 °F to 300 °F).

NOTE 1—The specified flow of air, 2.58 g/min \pm 0.02 g/min, (2 L/min at standard temperature and pressure), assumes dry air. It is not known that the original work involved dry air but it has since been shown that this can be a factor in reproducibility and should be addressed. A dew point of less than 10 °C at standard temperature and pressure will be satisfactory.

NOTE 2—To determine evaporation loss at temperatures above 150 °C (300 °F), see Test Methods ~~D2595~~.

6. Apparatus

6.1 *Evaporation Cell*, (Fig. 1) as described in Annex A1.

6.2 *Air Supply System*, capable of supplying to the cell the required flow of air free of entrained particles. A 400 mm (16 in.) length of 25 mm (1 in.) diameter pipe packed with glass wool has been found satisfactory for filtering the air.

6.3 *Oil Bath*, shown in Fig. 1a and described in Annex A1.

NOTE 3—Other constant-temperature baths may be used if they are equivalent in heat capacity and thermal gradient characteristics to the oil bath.

6.4 *Thermometers*—For tests at 100 °C (210 °F) an ASTM Thermometer having a range from 95 °C to 103 °C (204 °F to 218 °F) and conforming to the requirements for Thermometer S22C (S22F) as prescribed in Specification ~~E2251~~ shall be used. For tests at temperatures above 100 °C (210 °F), an ASTM Precision Thermometer conforming to the requirements for Thermometer S67C (S67F) as prescribed in Specification ~~E2251~~ is suitable.

6.5 *Flowmeter*—A rotameter calibrated to deliver air at a rate of 2.58 g/min \pm 0.02 g/min between 15 °C and 30 °C (60 °F and 85 °F) (2 L/min at standard temperature and pressure). It shall be furnished with a needle valve and mounted as shown in Fig. 1.

7. Sampling

7.1 Each grease test will require approximately 20 g to fill the sample cup for a single cup for a single run. Therefore, the sample presented for analysis should be large enough to make possible the selection of a representative portion for testing. Examine the sample for any indication of non-homogeneity such as oil separation, phase changes, or gross contamination. If any abnormal conditions are found, obtain a new sample.

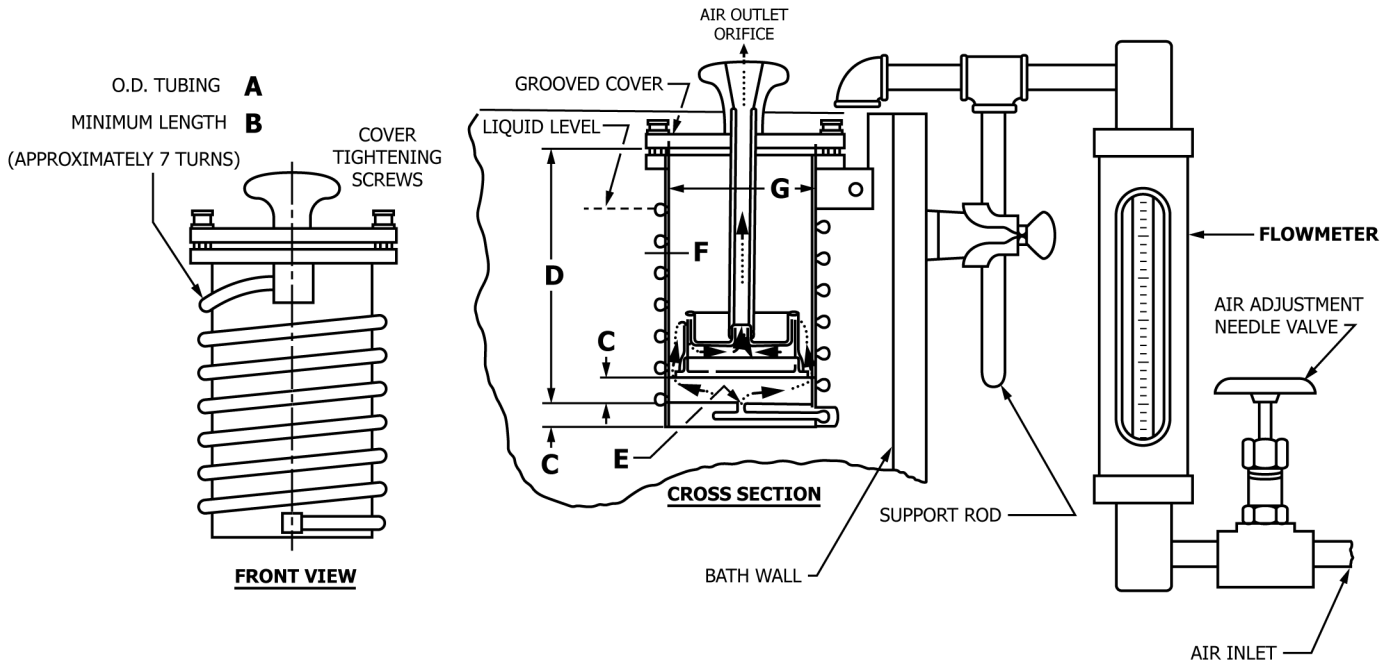

FIG. 1 Evaporation Test Cell

FIG. 1a Assembled Apparatus

Key	mm	in.	Key	mm	in.
A	6.4	0.25	D	124/130	5.0 ± 0.125
B	1830	72	E	3.2	0.125
C	13	0.5 ± 0.1 = 25	F	1.3/1.8	0.051/0.072
			G	73.1	2.875

Tolerances: ±0.4 mm (±0.0156 in.) unless otherwise noted

ASTM Standards
<https://standards.iteh.ai/>
 Document Preview

7.2 Each oil test will require at least 10 g of sample for a single run. Therefore, sufficient sample should be available to observe any gross contamination or phase separation. If any abnormal conditions are found, obtain a new sample.

8. Preparation of Apparatus

8.1 Clean and inspect all components and particularly for wear or damage to threads on sample cups and hood assemblies. Repair or replace if mating is impaired.

8.2 Verify unrestricted air flow through tubing on test cell and through eduction tube through cover.

8.3 Check that the oil bath is filled with a sufficient quantity of fluid to allow submersion of the evaporation cell to the proper level as required in 9.2.

8.4 Check flowmeter before running any test if there is doubt of its accuracy.

9. Procedure for Greases

9.1 Weigh the clean grease-sample cup and hood (Fig. 2) to the nearest 1 mg. Remove the hood and fill the cup with sample, taking care to avoid occlusion of air. Smooth the surface level with the rim of the cup with a straight-edged spatula. Remove with a clean cloth any grease which may remain on the rim or threads of the cup. Thread the hood tightly onto the cup without disturbing the smoothed grease surface. Weigh the assembly and record the mass of the sample to the nearest 1 mg.

9.2 With the cover in place, but without the hood and sample cup attached, allow the evaporation cell to acquire the temperature of the bath (controlled to ±0.5 °C (±1 °F)) at which the test is to be made by immersing the cell in the bath, as shown in Fig. 2. Ensure the cell is immersed to the designated depth using the support rod adjustment. Allow the cell to remain in the bath at least ½ h before beginning the test. During this period, allow clean air to flow through the cell at the prescribed rate, 2.58 g/min

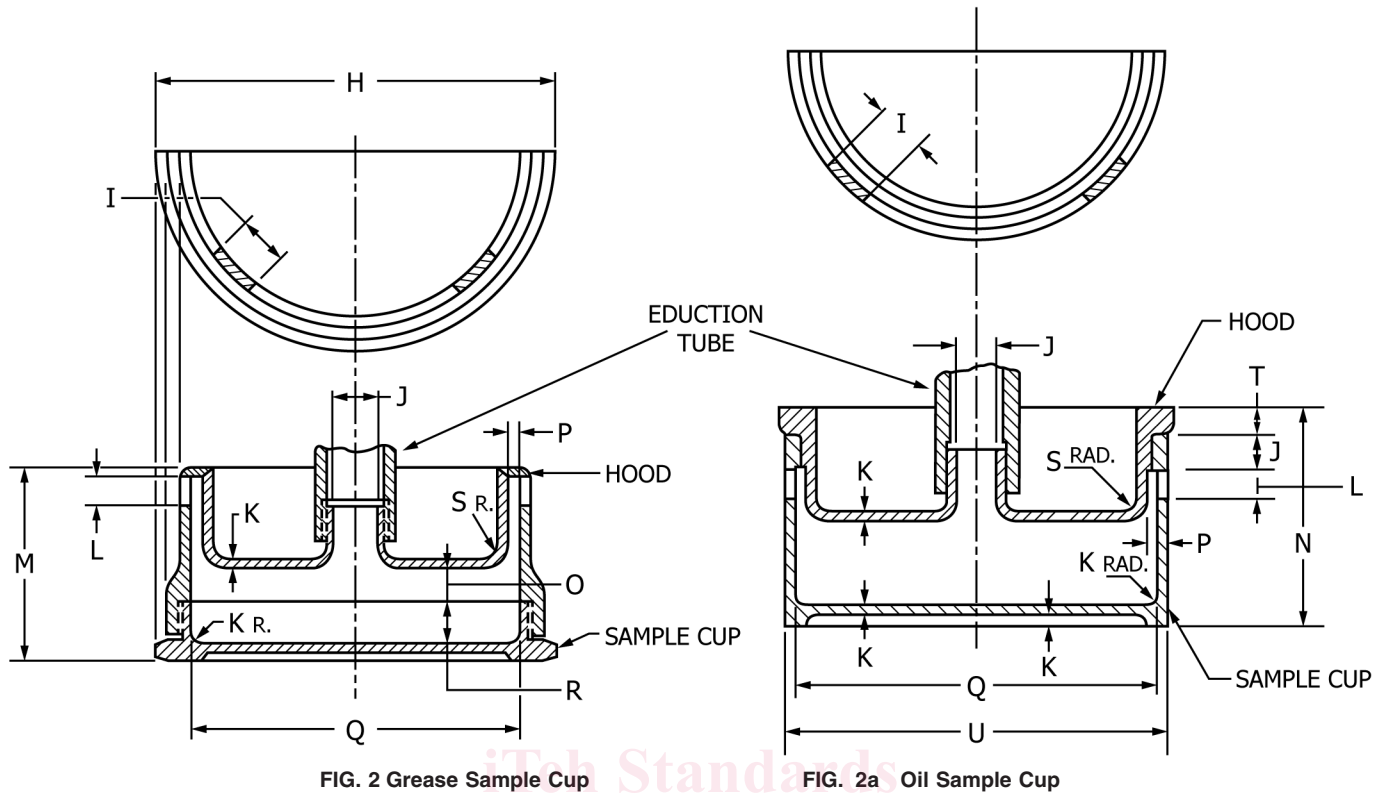

FIG. 2 Grease Sample Cup

FIG. 2a Oil Sample Cup

Key	mm	in.	Key	mm	in.
H	66	2.625	O	5.40/5.65	0.213/0.223
I	7.62	0.3125	P	1.45/1.70	0.057/0.067
J	6.35	0.25	Q	54.64/54.89	2.15/2.16
K	1.6	0.0625	R	6.9/7.4	0.27/0.29
L	5	0.1875	S	3	0.125
M	33	1.3125	T	4	0.16
N	40	1.6	U	58.7	2.3

Tolerances: ± 0.4 mm (± 0.0156 in.) unless otherwise noted

± 0.02 g ± 0.02 g/min (2 L/min at standard temperature and pressure), as indicated by the rotameter. Remove the cover, thread the weighed hood and sample cup into place, and replace the cover. Tighten the three cover-tightening screws securely to prevent air leakage under the cover. Pass clean air through the cell at the prescribed rate for 22 h \pm 5 min.

9.3 Remove the assembled sample cup and hood from the cell. At the end of the 22 h period allow to cool to room temperature. Determine the mass of the sample to the nearest 1 mg.

10. Procedure for Oils

10.1 Weigh the clean oil-sample cup and hood (Fig. 2a) to the nearest 1 mg. Transfer, by means of a pipet, 10.00 g \pm 0.05 g of sample to the cup. Assemble the cup and hood, being careful not to splash oil on the underside of the hood. Weigh the assembly and record the net sample mass to the nearest 1 mg.

10.2 Evaporate the sample as described in 9.2 and 9.3.

11. Calculation

11.1 Calculate the evaporation loss of the sample as follows:

$$\text{Evaporation loss, mass \%} = [(S - W)/S] \times 100 \quad (1)$$

where: