



Designation: D2595 – 22

Standard Test Method for Evaporation Loss of Lubricating Greases Over Wide-Temperature Range¹

This standard is issued under the fixed designation D2595; the number immediately following the designation indicates the year of original adoption or, in the case of revision, the year of last revision. A number in parentheses indicates the year of last reapproval. A superscript epsilon (ϵ) indicates an editorial change since the last revision or reapproval.

This standard has been approved for use by agencies of the U.S. Department of Defense.

1. Scope*

1.1 This test method covers the determination of evaporation loss of lubricating greases at temperatures between 93 °C and 316 °C (200 °F and 600 °F). This test method is intended to augment Test Method [D972](#), which is limited to 149 °C (300 °F).

1.2 The values stated in SI units are to be regarded as the standard. The values in parentheses are for information only.

1.3 *This standard does not purport to address all of the safety concerns, if any, associated with its use. It is the responsibility of the user of this standard to establish appropriate safety, health, and environmental practices and determine the applicability of regulatory limitations prior to use.* For specific safety information, see [5.2](#).

1.4 *This international standard was developed in accordance with internationally recognized principles on standardization established in the Decision on Principles for the Development of International Standards, Guides and Recommendations issued by the World Trade Organization Technical Barriers to Trade (TBT) Committee.*

2. Referenced Documents

2.1 ASTM Standards:²

[A240/A240M](#) Specification for Chromium and Chromium-Nickel Stainless Steel Plate, Sheet, and Strip for Pressure Vessels and for General Applications

[D972](#) Test Method for Evaporation Loss of Lubricating Greases and Oils

[D4175](#) Terminology Relating to Petroleum Products, Liquid Fuels, and Lubricants

[E2877](#) Guide for Digital Contact Thermometers

¹ This test method is under the jurisdiction of ASTM Committee [D02](#) on Petroleum Products, Liquid Fuels, and Lubricants and is the direct responsibility of Subcommittee [D02.G0.03](#) on Physical Tests.

Current edition approved Dec. 1, 2022. Published December 2022. Originally approved in 1967. Last previous edition approved in 2017 as D2595 – 17. DOI: 10.1520/D2595-22.

² For referenced ASTM standards, visit the ASTM website, www.astm.org, or contact ASTM Customer Service at service@astm.org. For *Annual Book of ASTM Standards* volume information, refer to the standard's Document Summary page on the ASTM website.

3. Terminology

3.1 Definitions:

3.1.1 For definitions of terms used in this test method, refer to Terminology [D4175](#).

3.1.2 *lubricating grease, n*—a semi-fluid to solid product of a thickener in a liquid lubricant.

3.1.2.1 *Discussion*—The dispersion of the thickener forms a two-phase system and immobilizes the liquid lubricant by surface tension and other physical forces. Other ingredients are commonly included to impart special properties.

3.1.3 *thickener, n*—in lubricating grease, a substance composed of finely divided particles dispersed in a liquid lubricant to form the product's structure.

3.1.3.1 *Discussion*—The thickener can be fibers (such as various metallic soaps) or plates or spheres (such as certain non-soap thickeners) which are insoluble or, at most, only very slightly soluble in the liquid lubricant. The general requirements are that the solid particles be extremely small, uniformly dispersed, and capable of forming a relatively stable, gel-like structure with the liquid lubricant.

4. Summary of Test Method

4.1 A weighed sample of grease in an evaporation cell is placed in a heating device maintained at the desired test temperature. Heated air is passed over the grease surface for 22 h \pm 0.1 h. The loss in weight of the sample due to evaporation is determined.

5. Significance and Use

5.1 The loss of volatile materials from greases and oils can adversely affect the original performance characteristics of a lubricant and, therefore, could be a significant factor in evaluating a lubricant for a specific use. Such volatiles can also be considered contaminants in the environment in which the lubricant is to be used. Correlation between results from this test method and service performance has not been established.

5.2 The test method can be used at any specified temperature between 93 °C and 316 °C (200 °F and 600 °F) that may be agreed upon by the user of the method. (**Warning**—This

*A Summary of Changes section appears at the end of this standard

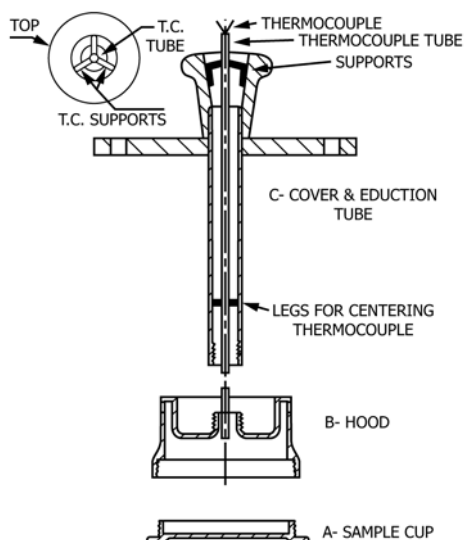
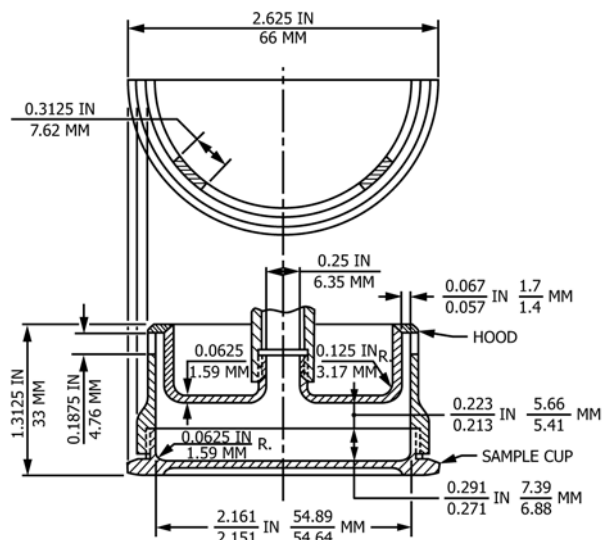

FIG. 1 Thermocouple Arrangement



SECTION OF GREASE SAMPLE CUP ALL DIMENSIONS ± 0.0156 in. (± 0.4 mm) UNLESS OTHERWISE SPECIFIED

FIG. 2 Evaporation Test Cell

test method should not be used at temperatures which exceed the flash point of the base oil of the grease.)

NOTE 1—The specified flow of air, $2.58 \text{ g/min} \pm 0.02 \text{ g/min}$, (2 L/min at standard temperature and pressure), assumes dry air. It is not known that the original work involved dry air but it has since been shown that this can be a factor in reproducibility and should be addressed. Air with a dew point of less than 10°C at standard temperature and pressure will be satisfactory.

6. Apparatus

6.1 *Evaporation Cell Assembly* (Fig. 1) consisting of the following items:

6.1.1 *Sample Cup, A.*

6.1.2 *Hood, B.*

6.1.3 *Cover and Education Tube, C*—These items (6.1.1 to 6.1.3) shall be constructed from a stainless steel conforming to Type 304 of Specification A240/A240M. Design dimensions and dimensional tolerances shall be as shown in Fig. 2 and Fig. 3.

6.1.4 *Gasket*—Shall be of a heat-resistant (315°C (600°F)) material. A gasket cut from 3.2 mm ($1/8 \text{ in.}$) TFE-fluorocarbon sheet has been found to work successfully.

6.1.5 *Thermocouple Tube and Supports*—The tube shall be of stainless steel having an outside diameter of $3.18 \text{ mm} \pm 0.025 \text{ mm}$ ($0.125 \text{ in.} \pm 0.001 \text{ in.}$) and fitted with stainless steel centering devices as shown in Fig. 1.

6.2 *Air Supply System*—Shall consist of a calibrated flowmeter, filtering device, and accessory valves capable of delivering and maintaining a flow of dust-free air at the rate of $2.58 \text{ g/min} \pm 0.02 \text{ g/min}$ between 15.6°C and 29.4°C (60°F and 85°F) (2 L/min at standard temperature and pressure).

6.3 *Heating Device*—An aluminum block heater similar to that shown in Fig. 4 has been found to be satisfactory. The aluminum block heater found to be satisfactory consists of an aluminum block approximately 254 mm (10 in.) wide, 356 mm (14 in.) long, and 203 mm (8 in.) deep. It is completely and adequately insulated on all sides. It is heated by two 650 W cartridge-type heaters and a 500 W ring-type heater under each

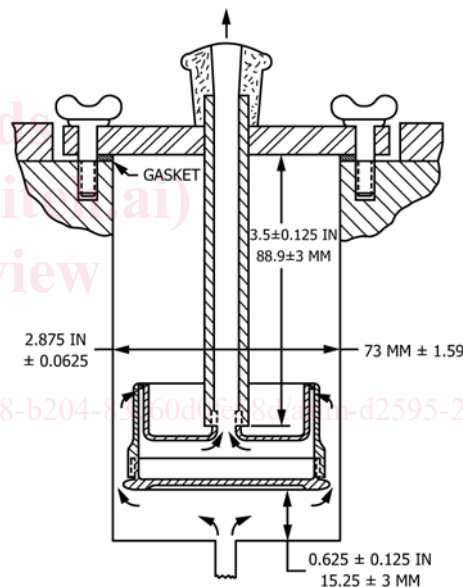

FIG. 3 Assembled Test Cell in Aluminum Block Heater

of the two cells as shown in Fig. 2. These were sufficient for the two-cell block but if additional evaporation spaces are included, additional or larger heaters are required. The heaters should be of sufficient size so that the block will return to the desired test temperature within 60 min after insertion of the test samples. It shall be equipped with sufficient heaters and control instruments to maintain the desired test temperature within 1°C ($\pm 2^\circ\text{F}$).

6.4 *Digital Contact Thermometers*—Digital contact thermometers, such as PRTs (platinum resistance thermometers) or thermocouples, having a range from -5°C to 400°C (20°F to 760°F) and conforming to the requirements as described in Guide E2877.

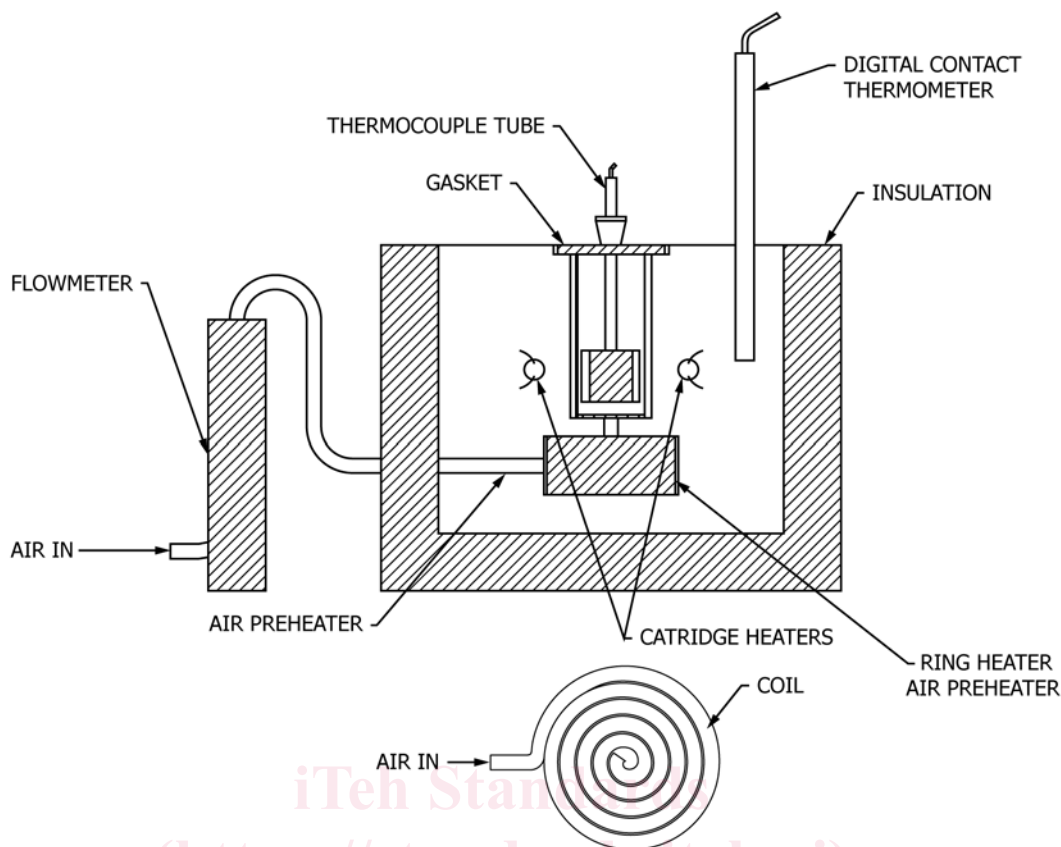

FIG. 4 Aluminum Block Heater

7. Sampling

7.1 Each test will require approximately 20 g to fill the sample cup for a single run. Therefore, the sample presented for analysis should be large enough to make possible the selection of a representative portion for testing. Examine the sample for any indication of non-homogeneity such as oil separation, phase changes, or gross contamination. If any abnormal conditions are found, obtain a new sample.

8. Preparation of Apparatus

8.1 Clean thoroughly all parts of the evaporation cell assembly.

8.2 With Fig. 1 as reference, connect the cover-education tube (C) to the hood (B). Adjust thermocouple tube so that the bottom of the tube is flush with face of hood as shown. Insert thermocouple in tube and adjust so that tip is flush with bottom edge of tube. Fasten the thermocouple securely in this position by compressing the top edge of the tube. Remove the tube-thermocouple assembly and disconnect the hood from the cover-education tube.

8.3 Clean thoroughly all parts of the evaporation cell assembly.

8.4 Place the cover-education tube (C) thermocouple assembly and gasket in the heating device as shown by Fig. 4. Fasten the cover securely in position.

8.5 Adjust the temperature of the heating device to maintain the test temperature and control within $\pm 1\text{ }^{\circ}\text{C}$ ($\pm 2\text{ }^{\circ}\text{F}$). Use the digital contact thermometer for this observation.

8.6 Regulate air flow through the assembly to $2.58\text{ g/min} \pm 0.02\text{ g/min}$ (2 L/min at standard temperature and pressure).

8.7 By regulating the air preheater, adjust the exit air temperature to the specified test temperature within $\pm 1\text{ }^{\circ}\text{C}$ ($\pm 2\text{ }^{\circ}\text{F}$). Use the thermocouple plus a temperature indicator or recorder for this measurement.

8.8 Maintain the temperatures of the heating device and exit air and the air flow rate for at least 0.5 h prior to test.

9. Procedure

9.1 Weigh the clean grease sample cup and hood to the nearest 0.01 g. Remove the hood and fill the cup with the test grease taking care to avoid occlusion of air. Smooth the surface level with the rim of the cup with a straight edge spatula. Remove with a clean cloth any grease which may remain on the rim or threads of the cup. Thread the hood tightly onto the cup without disturbing the smoothed grease surface. Weigh the assembly and record the net mass of the grease sample to the nearest 0.01 g.

9.2 Remove the cover, education tube, and thermocouple assembly from the heating device. Thread the weighed and assembled sample cup and hood into the education tube. Install