



Designation: ~~E2488 – 09 (Reapproved 2014)~~ E2488 – 22

## Standard Guide for the Preparation and Evaluation of Liquid Baths Used for Temperature Calibration by Comparison<sup>1</sup>

This standard is issued under the fixed designation E2488; the number immediately following the designation indicates the year of original adoption or, in the case of revision, the year of last revision. A number in parentheses indicates the year of last reapproval. A superscript epsilon ( $\epsilon$ ) indicates an editorial change since the last revision or reapproval.

### INTRODUCTION

Many of the Standards and Test Methods under the jurisdiction of ASTM committee E20 on Temperature Measurement make reference to the use of controlled temperature fluid baths for the calibration of thermometers by the comparison method. In this method the thermometer under test is measured while immersed in an isothermal medium whose temperature is simultaneously determined by a calibrated reference thermometer. The uncertainty of all such comparison calibrations depends upon how well the isothermal conditions can be maintained. The bath temperature must be stable over time and uniform within the working space at the operating temperatures. This guide provides basic information, options and instructions that will enable the user to prepare and evaluate controlled temperature baths for calibrations.

### 1. Scope

1.1 This guide is intended for use with controlled temperature comparison baths that contain test fluids and operate within the temperature range of ~~-100°C–100 °C~~ to 550°C:550 °C.

1.2 This guide describes the essential features of controlled temperature fluid baths used for the purpose of thermometer calibration by the comparison method.

1.3 This guide does not address the details on the design and construction of controlled-temperature fluid baths.

1.4 This guide describes a method to define the working space of a bath and evaluate the temperature variations within this space. Ideally, the working space will be as close as possible to isothermal.

1.5 This guide does not address fixed point baths, ice point baths, or vapor baths.

1.6 This guide does not address fluidized powder baths.

1.7 This guide does not address baths that are programmed to change temperature.

1.8 The values stated in SI units are to be regarded as standard. No other units of measurement are included in this standard.

<sup>1</sup> This guide is under the jurisdiction of ASTM Committee E20 on Temperature Measurement and is the direct responsibility of Subcommittee E20.07 on Fundamentals in Thermometry.

Current edition approved Dec. 1, 2014 Nov. 15, 2022. Published December 2014 December 2022. Originally approved in 2009. Last previous edition approved in 2009 2014 as ~~E2488 – 09: E2488 – 09 (2014)~~. DOI: ~~10.1520/E2488-09R14~~. 10.1520/E2488-22.

1.9 *This standard does not purport to address all of the safety concerns, if any, associated with its use. It is the responsibility of the user of this standard to establish appropriate safety, health, and environmental practices and determine the applicability of regulatory limitations prior to use.*

1.10 *This international standard was developed in accordance with internationally recognized principles on standardization established in the Decision on Principles for the Development of International Standards, Guides and Recommendations issued by the World Trade Organization Technical Barriers to Trade (TBT) Committee.*

## 2. Referenced Documents

### 2.1 ASTM Standards:<sup>2</sup>

- E1 Specification for ASTM Liquid-in-Glass Thermometers
- E344 Terminology Relating to Thermometry and Hydrometry
- E644 Test Methods for Testing Industrial Resistance Thermometers
- E839 Test Methods for Sheathed Thermocouples and Sheathed Thermocouple Cable

### 2.2 Other Documents:

- ITS-90 The International Temperature Scale of 1990<sup>3</sup>
- NIST Monograph 126 Platinum Resistance Thermometry<sup>4</sup>
- NIST Monograph 150 Liquid-in-Glass Thermometry<sup>4</sup>
- NIST SP 250-22 Platinum Resistance Thermometer Calibrations<sup>4</sup>
- NIST SP 250-23 Liquid-in-Glass Thermometer Calibration Service<sup>4</sup>

### 2.3 Military Standards:

- ~~MIL-STD-202G—Test Methods for Electronic and Electrical Component Parts<sup>5</sup>~~

## 3. Terminology

3.1 Standard terms used in this guide are defined in Terminology E344.

### 3.2 Definitions of Terms Specific to This Standard:

3.2.1 *bath gradient error, n*—the error caused by temperature differences within the working space of the bath.

3.2.2 *immersion error, n*—an error caused by heat conduction, radiation or both between the temperature sensing portion of the sensor used in the bath and the environment external to the measurement system. Immersion error is caused by an incorrect immersion length and the resulting incorrect thermal contact of the temperature sensing portion of the sensor with the medium under measurement.

3.2.3 *isothermal, adj*—of, related to, or designating a region of nominally uniform temperature.

3.2.4 *thermal stability, n*—the degree of variability of the temperatures within a specified working space over a specified time interval.

3.2.5 *working space, n*—the region within a controlled temperature bath where the temperature uncertainty is maintained within acceptable limits for the purpose of performing calibrations by the comparison method.

3.2.6 *working temperature range, n*—the minimum to maximum temperature range for which the bath system provides adequate stability and uniformity.

## 4. Summary of Practice

4.1 This guide is intended to provide basic information that will enable the user to evaluate various controlled temperature bath features and to enable the user to prepare and properly utilize such controlled temperature baths for calibration of thermometers by the comparison method.

<sup>2</sup> For referenced ASTM standards, visit the ASTM website, [www.astm.org](http://www.astm.org), or contact ASTM Customer Service at [service@astm.org](mailto:service@astm.org). For *Annual Book of ASTM Standards* volume information, refer to the standard's Document Summary page on the ASTM website.

<sup>3</sup> Preston-Thomas, H., *METROLOGIA*, Vol. 27, 1990, pp 3-10 and 107 (errata). Mangum, B. W., *JOURNAL OF RESEARCH*, National Institute of Standards and Technology, Vol 95, 1990, p. 69.

<sup>4</sup> Available from National Institute of Standards and Technology (NIST), 100 Bureau Dr., Stop 1070, Gaithersburg, MD 20899-1070, <http://www.nist.gov>.

5. Significance and Use

5.1 The design of a controlled temperature bath will determine what thermometers can be calibrated and to what extent an isothermal condition is achieved. The lack of thermal stability and uniformity of the bath are sources of error that contribute to the overall calibration uncertainty.

5.2 This guide describes a procedure for determining the effective working space for a controlled temperature fluid bath.

5.3 This guide describes a procedure for determining the thermal stability within a controlled temperature fluid bath. Overall thermal stability is composed of the bath performance as specified by the manufacturer of the bath equipment and as a component of calibration uncertainty.

5.4 This guide describes a procedure for determining the temperature uniformity of the working space of the controlled temperature fluid bath.

6. Procedure

6.1 *Bath System*—A controlled temperature fluid bath system will incorporate most, if not all, of the following components: a fluid medium; a mechanical design that provides for containment and circulation of the fluid; a monitoring ~~thermometer~~, thermometer; a temperature control unit; and, and elements that provide for heating, cooling, or both. There are many commercially available controlled temperature baths. These baths operate from as low as  $-100^{\circ}\text{C}$ - $100^{\circ}\text{C}$  to as high as  $+550^{\circ}\text{C}$ ;  $+550^{\circ}\text{C}$ , although no single bath system is capable of operation over that entire range. The design of each individual bath will create practical limits for the working temperature range. These limits are determined by considering the minimum and maximum temperature ratings for each of the components in the bath system. The user is advised to carefully review the bath manufacturer’s literature to be certain that the bath system is suitable for the intended calibration temperature range and the types of thermometers to be tested. Figs. 1-4 represent various designs of controlled temperature fluid bath systems. Fig. 4 shows a block diagram of a comparison calibration setup.

6.1.1 *Fluid Medium*—There are many types of fluid media suitable for use in liquid temperature comparison baths. The physical properties of the medium will establish the limits for the safe operating temperature range, as well as determine the overall performance of the bath system. Fig. 5 provides a partial listing of common bath media that have been used successfully for liquid temperature comparison baths. This guide is not intended to restrict the user to only those fluids shown in Fig. 5. It is advisable for the user to review carefully the manufacturer’s literature on any alternative fluid to be certain that it complies with the safety considerations of 6.1.1.1.

6.1.1.1 *Safety and Environmental Impact Considerations*—(See 1.81.9.) It is strongly recommended that the Material Safety Data Sheet (MSDS) of any material used as a fluid medium be reviewed and understood by the user before the material is handled for

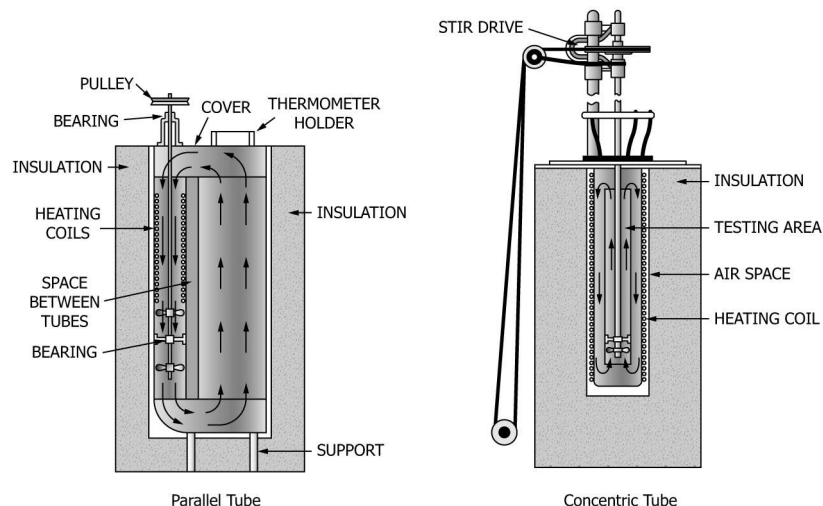

FIG. 1 Alternative Designs of Top Stirred Comparison Baths Without Controllers-Controllers

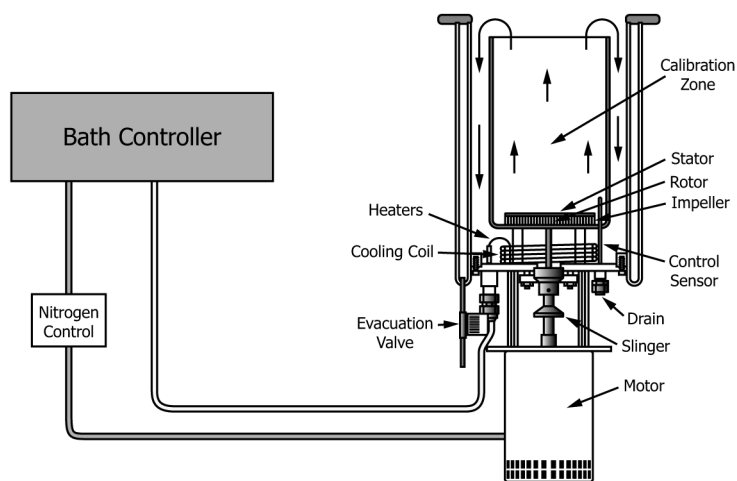

FIG. 2 Sample Design of Bottom-Stirred Comparison Bath with Controller

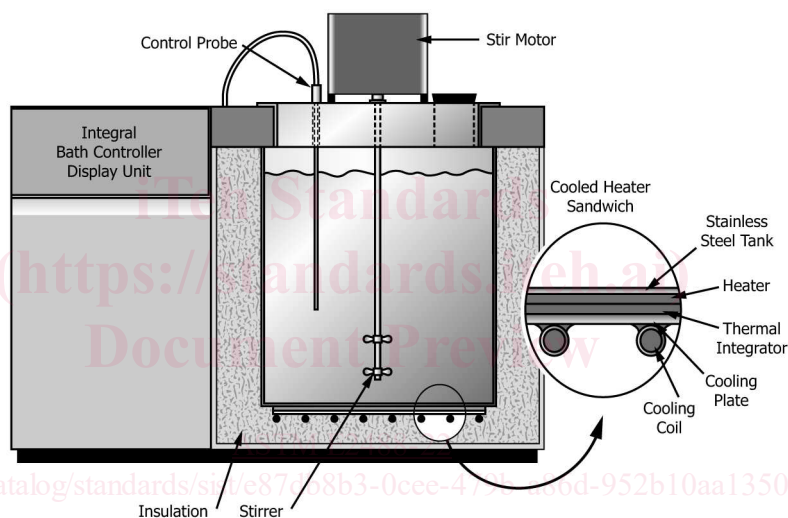

FIG. 3 Sample Design of Comparison Bath with Integral Heating, Cooling and Controller

the first time. The data sheets of all test fluids should be kept readily available during bath operation in case of accidents or spills. Additionally, some producers of bath fluids provide a Global Warming Potential Index in their specifications that should be considered when choosing a bath fluid.

(1) *Temperature Limits*—Fig. 5 provides minimum and maximum safe operating temperatures for several common bath media. Flash point temperatures are also given for certain flammable media. Consult the manufacturer’s MSDS document for each bath fluid used.

(2) *Flammability*—Fluids are easily ignited above their flash point. Whenever possible, the bath fluid shall be maintained below the specified flash point. Some fluids are flammable at room temperature so the user must exercise caution to prevent the exposure of these fluids to open flames or sparks. As a general safety practice, a fire suppression system (for example, extinguisher, blankets, hoods, lids, etc.) should always be readily available when operating a bath with flammable media.

(3) *Ventilation*—Proper ventilation, such as exhaust hoods or vents, is required to remove any fumes or vapors that may be toxic or otherwise harmful to the operators performing the calibration.

(4) *Toxicity*—Protective clothing and shielding shall be required for operators who must handle fluids that are environmentally hazardous or toxic. Proper disposal of excess fluids, spills, residues, or materials contaminated by the fluids shall be in accordance with all regulatory policies.

(5) *Chemical Stability*—The bath fluid shall be chemically stable at the operating temperatures and inert to both the container and the components or elements submitted to comparison testing. **Warning**—The salts or molten metals used for calibration at high temperatures (above 260°C) are particularly corrosive to many materials. Special care should be taken to determine the compatibility of the materials used in construction of the thermometer. **DISCUSSION**—Chemical instability may change the

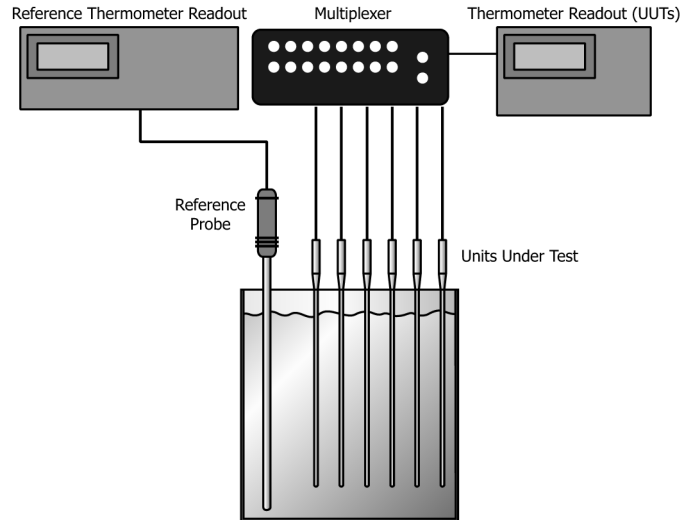

FIG. 4 Block Diagram of Comparison Calibration Setup

Bath fluid	min.	max.	comments/limitations
Water	0.05 °C	95 °C	Freeze = 0 °C, Boil = 100 °C, (d)
Ethylene Glycol/Water (1:1)	-35 °C	107 °C	
Mineral oil (8042-47-5)	0 °C	120 °C	Flash = 168 °C, (a)
Aliphatic Hydrocarbon	-65 °C	50 °C	Flash = 60 °C
Light mineral oils	-75 °C	200 °C	(a), depends on viscosity
Transformer oil, Motor oil	0 °C	75 °C	Flash = 145 °C
Methylcyclohexane	-100 °C	0 °C	Flash = -5 °C
PCTFE fluid (Halocarbon 0.8)	-100 °C	70 °C	Boil ca 132 °C, (b), (e)
Hydrofluoroether (HFE-7500)	-75 °C	100 °C	Boil = 130 °C, (f)
Perfluorocarbon fluid (FC-40)	0 °C	150 °C	(a), (f)
Perfluorocarbon fluid (FC-70)	50 °C	200 °C	(a), (f)
Perfluorocarbon fluid (FC-77)	-100 °C	0 °C	(f)
Perfluorocarbon fluid (D02-TS)	-65 °C	150 °C	(a), (g)
Perfluorocarbon fluid (UCON-WS)	0 °C	200 °C	(a), (h)
Silicone oil 710	80 °C	300 °C	Flash = 302 °C, (a)
Silicone oil 200.05	-40 °C	125 °C	Flash = 133 °C, (a)
Silicone oil 200.10	-30 °C	160 °C	Flash = 211 °C, (a)
Silicone oil 200.20	10 °C	230 °C	Flash = 246 °C, (a)
Silicone oil 200.50	30 °C	275 °C	Flash = 318 °C, (a)
Silicone oil 210H	50 °C	175 °C	Flash = 288 °C, (a)
Silicone oil 550	0 °C	230 °C	Flash = 308 °C, (a)
Liquid tin	315 °C	540 °C	(a)
Salt .40NaNO <sub>2</sub> / .07NaNO <sub>3</sub> / .53KNO <sub>3</sub>	180 °C	550 °C	Decomposes @ 593 °C, oxidizer, (a), (c)
Molten salts	200 °C	620 °C	(a), (c)

Notes:

- (a) Avoid introduction of water or wet objects above 100 °C.
- (b) Avoid Aluminum.
- (c) Corrosive, can etch glass.
- (d) Practical limits for a stirred water bath are 0.05 °C to 95 °C.
- (e) Halocarbon Products Corporation
- (f) 3M Specialty Materials
- (g) Solvay Solexis, Inc.
- (h) DOW Chemical Company

FIG. 5 Typical Bath Fluid Media and Useful Operating Temperature Ranges

properties of a bath fluid in one or more of the following ways: (1) Safety—The flash point of the bath fluid may change over time due to the chemical decomposition, breaking of chemical bonds, caused by repeated use at high temperatures. (2) Performance—A bath fluid that is subject to polymerization when exposed to high temperatures for extended periods will become more viscous. The increase in viscosity can degrade performance and will make maintenance and cleanup very difficult.

NOTE 1—Chemical instability may change the properties of a bath fluid in one or more of the following ways: (1) Safety—The flash point of the bath



fluid may change over time due to the chemical decomposition, breaking of chemical bonds, caused by repeated use at high temperatures. (2) Performance—A bath fluid that is subject to polymerization when exposed to high temperatures for extended periods will become more viscous. The increase in viscosity can degrade performance and will make maintenance and cleanup very difficult.

(6) *Expansion of Fluids*—The bath system must be designed to provide sufficient room for the expansion of fluids when heated so that spills and overflows do not occur. It is also important to consider that fluids will contract when being refrigerated to very low temperatures and then expand when allowed to return to room temperature.

(7) *Cross Contamination Between Baths*—Proper caution must be taken to avoid the mixing of test fluids when thermometers are transferred from one adjacent bath to another during multiple calibrations. Depending upon the fluids and temperatures involved, this can be a minor problem compromising bath performance, or it can be a major safety issue. For example, fluids at temperatures above  $100^{\circ}\text{C}$  may react violently if water or a wet object is immersed into them. The introduction of water or organic materials into a molten salt bath can also produce violent reactions.

6.1.1.2 *Performance Considerations*—Considerations—The physical properties of the fluid media will determine the overall performance of the bath system.

(1) *Fluid Viscosity*—The fluid viscosity can vary greatly over a wide temperature range and this can lead to problems with stirring, agitation, or the establishment of undesirable temperature gradients. In practice, a bath fluid with a viscosity of ten centistokes, or less, usually provides good stirring and mixing action. When the viscosity of the fluid becomes 50 centistokes, or greater, the stirring and mixing becomes less effective and the possibility of temperature gradients is increased. High viscosity also leads to excessive fluid drag-out. These viscosity numbers are intended only as a general observation. The selection of a test fluid should be based upon a careful consideration of many factors.

(2) *Volatility*—Fluids operated near their boiling points, or that have a high vapor pressure under normal laboratory environments will present a problem in controlling the bath temperature. Evaporation from the surface of the liquid will produce an undesirable temperature gradient because of the increased cooling effect at the surface. In addition, the loss of bath fluid over time due to evaporation will cause the length of immersion of the thermometers to vary unless the bath design is such that it replenishes the lost fluid.

(3) *Moisture Condensation*—Refrigerated baths can cause atmospheric moisture to condense on the surfaces above the fluid. Precipitation of this moisture into the test fluid can seriously degrade the performance of the bath system.

(4) *Dielectric Properties*—The volume resistivity, dielectric strength and dielectric constant of the fluid are important considerations whenever the thermometer or device under test has exposed conductors or electrical contacts wetted by the fluid. In general, the dielectric strength of the fluids should be as high as practical when testing resistance thermometers. Fluids that absorb moisture over time (for example, isopropyl alcohol) should be periodically checked and either replaced or treated to remove the moisture.

(5) *Thermal Conductivity*—The thermal conductivity of the bath fluid medium should be relatively high. This will keep bath temperature gradients within the fluid as small as possible, and will also subject the device under test to a more uniform temperature over its immersed surface.

(6) *Specific Heat*—It is not always possible to select fluids that have ideal properties for each bath system or range of temperatures that will be encountered. Some compromises in the selection of bath fluids must be expected. However, when all other factors are essentially equal, it is advisable to select the fluid with the highest specific heat. A fluid with a higher specific heat means that for a given amount of heat loss or gain to the bath system, a smaller change in the temperature of the bath fluid will result.

6.1.2 *Mechanical Design*—The mechanical design of the bath and the materials employed in its construction determine the limits for the working temperature range as well as the overall stability and uniformity of the bath. A poorly designed bath will not provide the desired levels of uncertainty needed for precision calibration. However, the performance of a marginal bath system may be improved to acceptable levels of uncertainty by the use of an equalizing block immersed in the bath fluid.

6.1.2.1 *Container*—The material used to contain the fluid in a bath system must be compatible with the medium selected. Most commercial baths are constructed of a borosilicate glass or a stainless steel. These materials provide chemical resistance to a wide range of fluids and operating temperatures. Nevertheless, it is advisable that the user checks the chemical compatibility of the desired test fluid with the container materials and to avoid all circumstances where chemical reaction or corrosion can exist.

6.1.2.2 *Insulation and Non-metallic Materials*—The types and temperature ratings of insulation materials used in the construction of the bath system will establish the limits for the working temperature range. Gaskets, seals, and plastic insulating materials used in bath construction will become brittle or cracked when exposed to temperatures below their minimum temperature rating. These materials will also be susceptible to swelling, deformation, or melting when exposed to temperatures that are above their high temperature rating. Materials that may be damaged by excessive temperature exposures can lead to fluid leaks, loss of thermal insulating properties or loss of electrical insulating properties.

6.1.2.3 *Circulation or Mixing*—Stirring and circulation of the fluids is very important in order to minimize gradients within the

bath container. There are baths designed to provide a laminar flow of the bath fluid—examples of this type may be found in Test Methods [E644](#) and [Method E839](#)—however, these baths are usually used for thermal response-time testing and not used for calibration of thermometers by the comparison method. Many commercially available calibration baths are designed to provide both vertical and horizontal mixing of the bath fluid to minimize gradients within the media. Circulating pumps or impellers mounted on motorized shafts typically provide the mixing action. There are limits to the amount of stirring that is desirable for a given bath design. Too much agitation of a liquid can lead to foaming or frothing as air mixes into the medium. Fluid separation (cavitation) may occur if the fluid flow rate is too high. Such turbulent liquid flow can result in temperature instability. Too little stirring will obviously lead to the establishment of gradients and thus poor uniformity.

**6.1.2.4 Heating and Cooling Systems**—Commercial baths may contain heating elements, cooling elements, or both, depending upon the desired range of operating temperatures. Heating or cooling elements, or both, should be carefully selected so that the amount of heat transfer to the bath fluid is ideal. Too much heat transfer to or from the fluid medium will result in excessive temperature variation over time (for example, poor stability of bath temperature). If the cooling elements are built into the bath, then the user must be aware of the upper and lower temperature limits imposed by the refrigerant gases or liquids used in the system. Widely separated heating and cooling elements within a bath container can lead to significant temperature gradients. Modern, commercially available, precision laboratory baths offer integral heating and cooling elements or surfaces (see [Fig. 3](#)). Such integrated elements or surfaces give the appearance of a single thermal energy source and this has the effects of reducing temperature gradients and improving bath stability.

**6.1.2.5 Heat Capacity**—The volume of the bath relative to the volume of thermometers or other devices immersed in the bath must be sufficient so that the work introduced does not significantly affect the temperature of the fluid. Classically, a bath with a volume equal to 1000 times the volume displaced by the units under test has been considered ideal. This may not always be practical to achieve for a variety of reasons, but the test operator must be aware of the limitations imposed on the bath system and factor this into uncertainty reporting. The depth of bath container must also be large enough to accommodate the minimum immersion depth of the thermometer or other device under test. Ideally, the heat capacity of the bath should be such that the temperature returns to a stable condition within a short time and the stem effect error is minimal.

**6.1.3 Control Circuitry**—Commercial baths with advertised temperature control ranging from as little as  $\pm 0.001^\circ\text{C} \pm 0.001^\circ\text{C}$  for sophisticated, precision laboratory baths; to as much as  $\pm 3^\circ\text{C} \pm 3^\circ\text{C}$  for general-purpose testing baths are available. See [section 6.2](#) to determine how to verify the bath control.

**6.1.3.1 Control Unit**—The control unit senses the temperature of a thermometer immersed in the bath fluid and adjusts the heat transferred to or from the bath by varying or cycling the heating or cooling elements, or both. On-off control of the heating or cooling elements provides poorer temperature control because the bath fluid is generally being driven between two temperature extremes. For greater control of the bath fluid, it is desirable to transfer the heat energy in smaller increments. As such, proportional controllers are used in the more advanced bath designs. Such advanced baths will often use a microprocessor-based bath controller and a sensitive thermometer such as a thermistor, resistance temperature detector or calibrated thermocouple. Safety cut-outs can be set electronically with microprocessor-based controllers.

**6.1.3.2 Control and Monitoring Thermometer(s)**—The control thermometer provides input to the control unit to adjust the fluid temperature. The monitoring thermometer provides an indication to the test operator that the bath system is under control at the desired temperature. These may or may not be independent thermometers and in the case of the monitoring thermometer, it may or may not be the reference thermometer being used for the comparison measurements. In any event, the design of the thermometer itself is an important consideration in order to minimize thermal gradients within the bath fluid and to achieve the best stability. A proper thermometer design will take into consideration the following features:

(1) *Thermal Response*—The difference between the thermal response time of the control/monitoring thermometer and that of the thermometer under test is a major consideration. For example, it is inappropriate to use a large mass thermometer to monitor the temperature of a bath in which fast-response, small-mass thermometers or other sensing devices are to be calibrated. The large thermal mass of the monitor will integrate the temperature fluctuations of the test medium so that the indicated temperature control variation is just a fraction of the actual variation. To determine the true stability of the bath it is necessary to examine the temperature excursions exhibited by the thermometer under test as well as those of the monitor. To minimize the difference in the thermal response of the two thermometers it is suggested that the fast response unit be mass-loaded or that a heat sink is used for both the monitor and the unit under test to force them to both exhibit the same fluctuations. A thermal equalizing block is often used for this purpose. Usually the blocks are constructed of copper, aluminum, or some other thermally conductive metal that is compatible with both the thermometers under test and the fluid medium. The block is immersed completely into the bath fluid and suspended in such a way that there is fluid flow all around the exterior of the block.

(2) *Uncertainty of the Monitor/Reference Thermometer*—The approximate attainable uncertainties for several different types of thermometers are indicated below. The monitoring thermometer that is used to observe the bath temperature fluctuations and