



Designation: ~~E2023–21~~ E2023 – 22

## Standard Practice for Fabrication of Neutron Radiographic Sensitivity Indicators<sup>1</sup>

This standard is issued under the fixed designation E2023; the number immediately following the designation indicates the year of original adoption or, in the case of revision, the year of last revision. A number in parentheses indicates the year of last reapproval. A superscript epsilon ( $\epsilon$ ) indicates an editorial change since the last revision or reapproval.

### 1. Scope

1.1 This practice covers the fabrication of Sensitivity Indicators (SI), which can be used to determine the relative quality of film radiographic images produced by direct, thermal neutron radiographic examination.

1.2 *Units*—The values stated in inch-pound units are to be regarded as standard.

1.3 *This standard does not purport to address all of the safety concerns, if any, associated with its use. It is the responsibility of the user of this standard to establish appropriate safety, health, and environmental practices and determine the applicability of regulatory limitations prior to use.*

1.4 *This international standard was developed in accordance with internationally recognized principles on standardization established in the Decision on Principles for the Development of International Standards, Guides and Recommendations issued by the World Trade Organization Technical Barriers to Trade (TBT) Committee.*

### 2. Referenced Documents

2.1 *ASTM Standards:*<sup>2</sup>

[E543 Specification for Agencies Performing Nondestructive Testing](#)

[E545 Test Method for Determining Image Quality in Direct Thermal Neutron Radiographic Examination](#)

[E748 Guide for Thermal Neutron Radiography of Materials](#)

[E1316 Terminology for Nondestructive Examinations](#)

### 3. Terminology

3.1 *Definitions*—For definitions of terms used in this practice, see Terminology [E1316](#), Section H.

### 4. Summary of Practice

4.1 The Sensitivity Indicator (SI) is used for qualitative determination of the sensitivity of detail visible on the neutron radiograph. It consists of a step wedge containing gaps and holes of known dimensions. Visual inspection of the image of this device provides subjective information regarding total radiographic sensitivity with respect to the step-block material.

4.2 Neutron radiography practices are discussed in Guide [E748](#). The neutron radiograph used to determine image quality using the SI shall meet the requirements of Test Method [E545](#).

<sup>1</sup> This practice is under the jurisdiction of ASTM Committee [E07](#) on Nondestructive Testing and is the direct responsibility of Subcommittee [E07.05](#) on Radiology (Neutron) Method.

Current edition approved Nov. 1, 2021/Dec. 1, 2022. Published November 2021/December 2022. Originally approved in 1999. Last previous edition approved in 2019/2021 as ~~E2023 – 19~~ E2023 – 21. DOI: ~~10.1520/E2023-21~~ 10.1520/E2023-22.

<sup>2</sup> For referenced ASTM standards, visit the ASTM website, [www.astm.org](http://www.astm.org), or contact ASTM Customer Service at [service@astm.org](mailto:service@astm.org). For *Annual Book of ASTM Standards* volume information, refer to the standard's Document Summary page on the ASTM website.

5. Significance and Use

5.1 The only truly valid image quality indicator is a material or component, equivalent to the part being neutron radiographed, with a known standard discontinuity, inclusion, omission, or flaw (reference standard comparison part). The SI is designed to substitute for the reference standard, providing qualitative information on hole and gap sensitivity in a single unit. Fabrication in accordance with this practice is vital for accurate and consistent measurements.

5.2 This practice shall be followed for the fabrication of all SIs to be used with Test Method E545 to determine image quality in direct thermal neutron radiography. Devices constructed to previous versions of this practice, or Test Method E545 for devices built between 1981 and 1991, can also be used.

6. Basis of Application

6.1 *Qualification of Nondestructive Agencies*—If specified in the contractual agreement, NDT agencies shall be qualified and evaluated as described in Specification E543. The applicable edition of Specification E543 shall be specified in the contractual agreement.

6.2 *Procedures and Techniques*—The procedures and techniques to be utilized shall be as described in this practice unless otherwise specified. Specific techniques may be specified in the contractual agreement.

6.3 *Reporting Criteria/Acceptance Criteria*—Reporting criteria for the examination results shall be in accordance with Sections 9 and 10, unless otherwise specified. Acceptance criteria, for example, reference radiographs, shall be specified in the contractual agreement.

6.4 Re-examination of repaired/reworked items is not addressed in this practice and, if required, shall be specified in the contractual document.

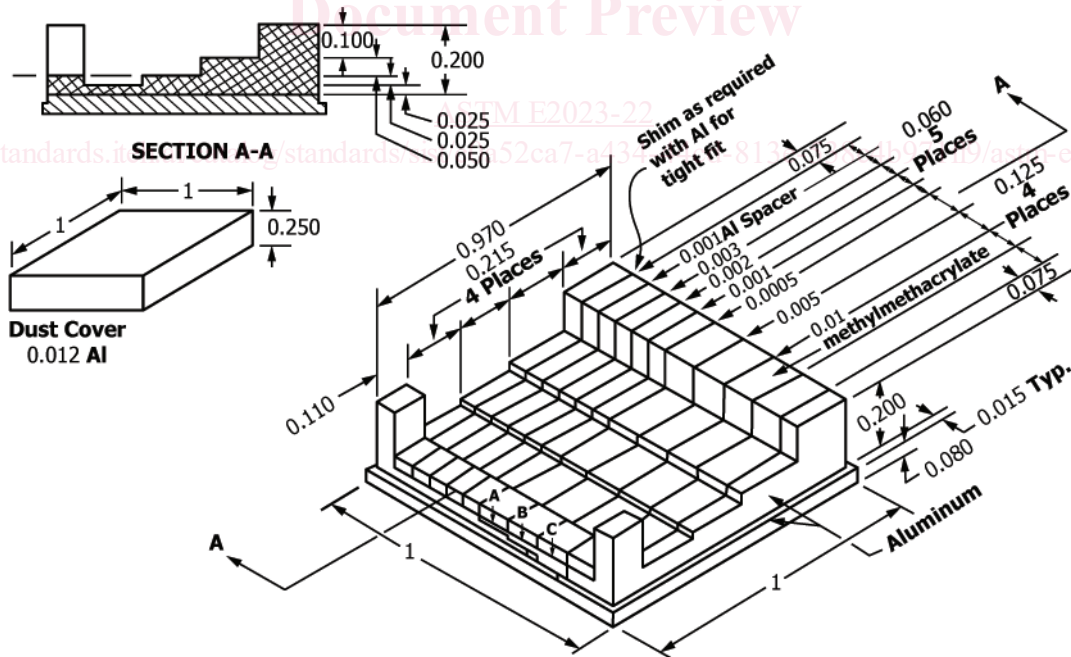

Material — Methylmethacrylate

Shim Section	Thickness	Hole Diameter
A	0.005	0.005
B	0.010	0.010
C	0.020	0.020

NOTE 1—All dimensions are in inches.

FIG. 1 Sensitivity Indicator

7. Sensitivity Indicator (SI)

7.1 The Sensitivity Indicator (SI) shall be constructed of cast acrylic resin and aluminum. The construction and dimensions are shown in Fig. 1.

7.2 The acrylic resin shall be methylnmethacrylate.

7.3 All dimensional tolerances are as noted on the figures.

7.4 Aluminum shims and strips shall be 99.9 % pure elemental material.

7.5 The SI may be encased in a 6061 aluminum dust cover, 0.012 in. thick.

8. Fabrication<sup>3</sup>

8.1 Components:

8.1.1 Mill a Channel, 0.850 in. wide from an aluminum block, 1 in. wide by at least 0.303 in. high. The length of this channel establishes how many SI indicators can be fabricated simultaneously. 6.5 in. is common (to produce 6 SI) but other lengths may be used. The channel begins 0.075 in. from edge A and leaves 0.103 in. aluminum in the bottom of the channel (see Fig. 2).

8.1.2 Mill the A Channel (see Fig. 1), within this channel, 0.125 in. wide by 0.005 in. deep for the length of the aluminum block. The near edge of channel A shall be 0.450 in. from edge A (see Fig. 3).

8.1.3 Mill the B Channel, adjacent to the A channel, 0.125 in. wide by 0.010 in. deep for the length of the aluminum block. The near edge of channel B shall be 0.325 in. from edge A (see Fig. 3).

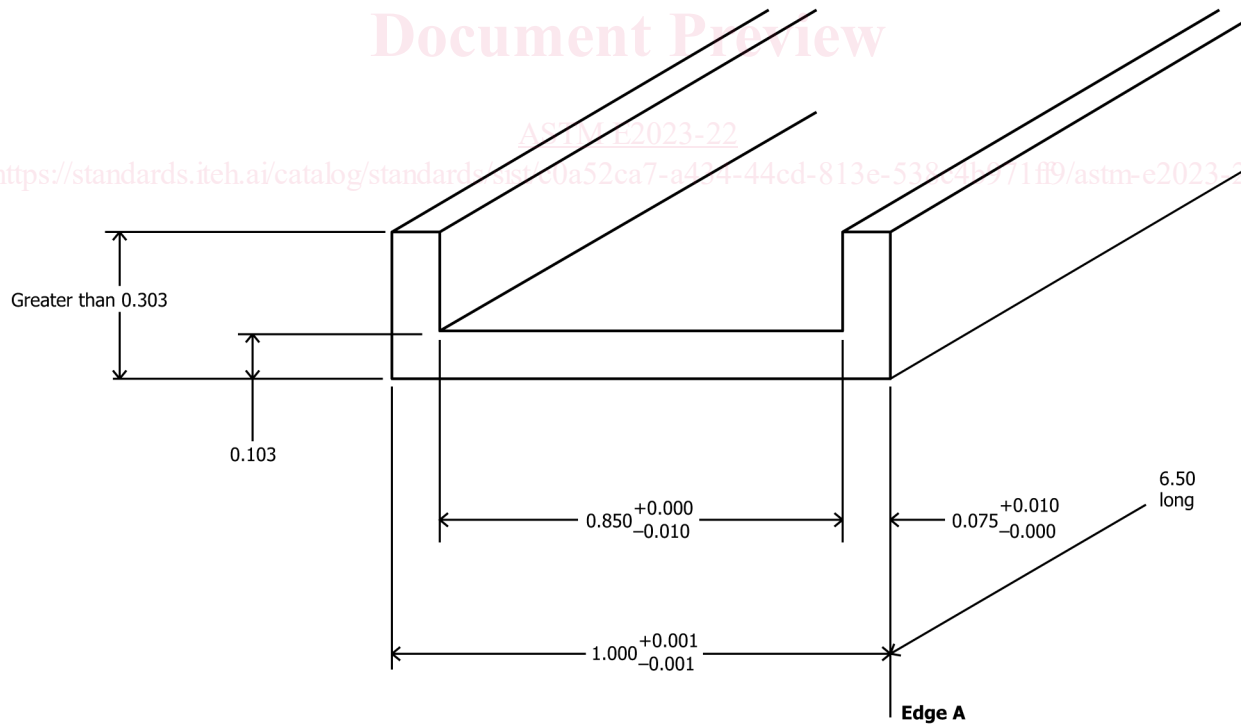

NOTE 1—Unless otherwise specified, use the following:  
 Dimensions are in inches.  
 Tolerances on machined dimensions: .XX = ±.01 .XXX = ±.002.  
**FIG. 2 Main Channel in Aluminum Block**

<sup>3</sup> The instructions in Section 8 assume the simultaneous fabrication of six units for practical reasons. Units may be fabricated in other quantities, if desired.

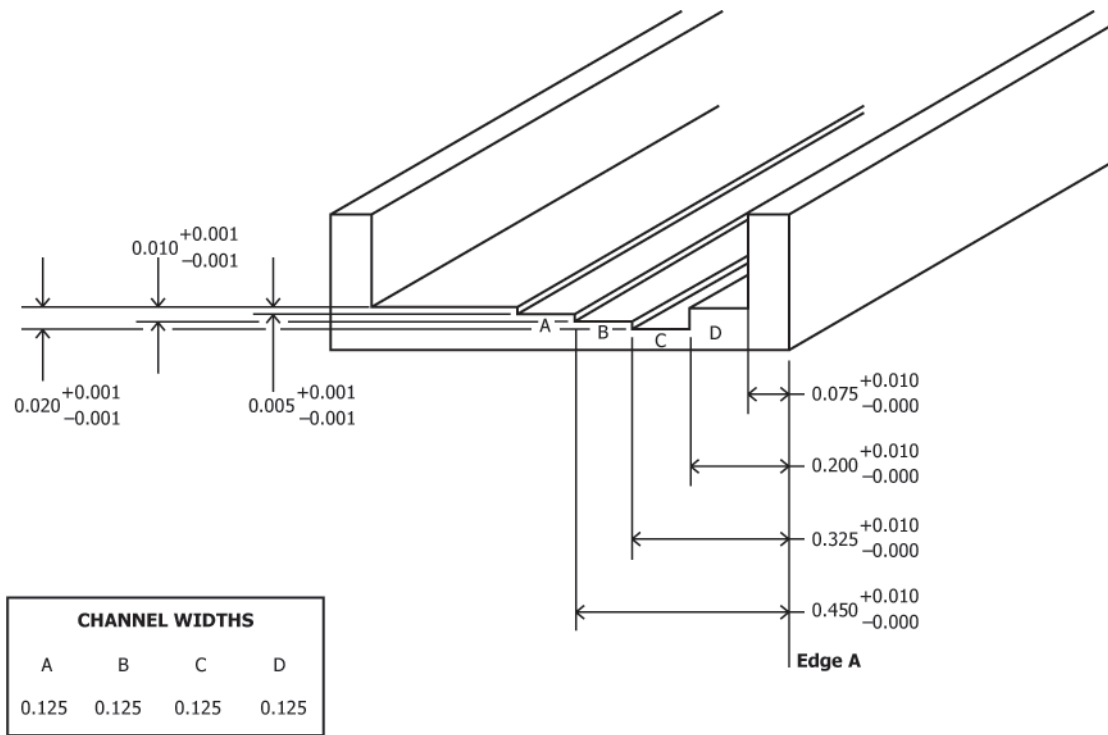

NOTE 1—Unless otherwise specified, use the following:  
 Dimensions are in inches.

Tolerances on machined dimensions: .XX = ±.01 .XXX = ±.002.

FIG. 3 Channels A Through D in Main Channel

iteh standards  
 (https://standards.iteh.ai)  
 Document Preview

8.1.4 Mill the C Channel, adjacent to the B channel, 0.125 in. wide by 0.020 in. deep for the length of the aluminum block. The near edge of channel C shall be 0.200 in. from edge A (see Fig. 3).

8.1.5 Mill into the D channel space to receive the tab depicted in Fig. 4, to a depth of 0.020 in. at appropriate spacing if multiple devices are being constructed.

8.1.6 Prepare five methacrylate strips, 0.060 in. thick by at least 0.200 in. wide by the aluminum block length. These strips will be used in 8.2.8.

8.1.7 Prepare four methacrylate strips, 0.125 in. thick by at least 0.200 in. wide by the aluminum block length. These strips will be used in 8.2.2.

8.1.8 Prepare one strip each from aluminum shim stock, at least 0.200 in. by the aluminum block length, with the following thicknesses:

- 0.0005 in.
- 0.0010 in.
- 0.0020 in.
- 0.0030 in.
- 0.0040 in.
- 0.0050 in.
- 0.0100 in.

8.1.9 Prepare methacrylate shims according to Fig. 4.

8.1.10 To verify that the various shims have the proper holes drilled into them, a certified hole measurement report is required.

8.1.11 To protect the SI during use, it is highly recommended that a dust cover be kept on the unit. One dust cover for each SI

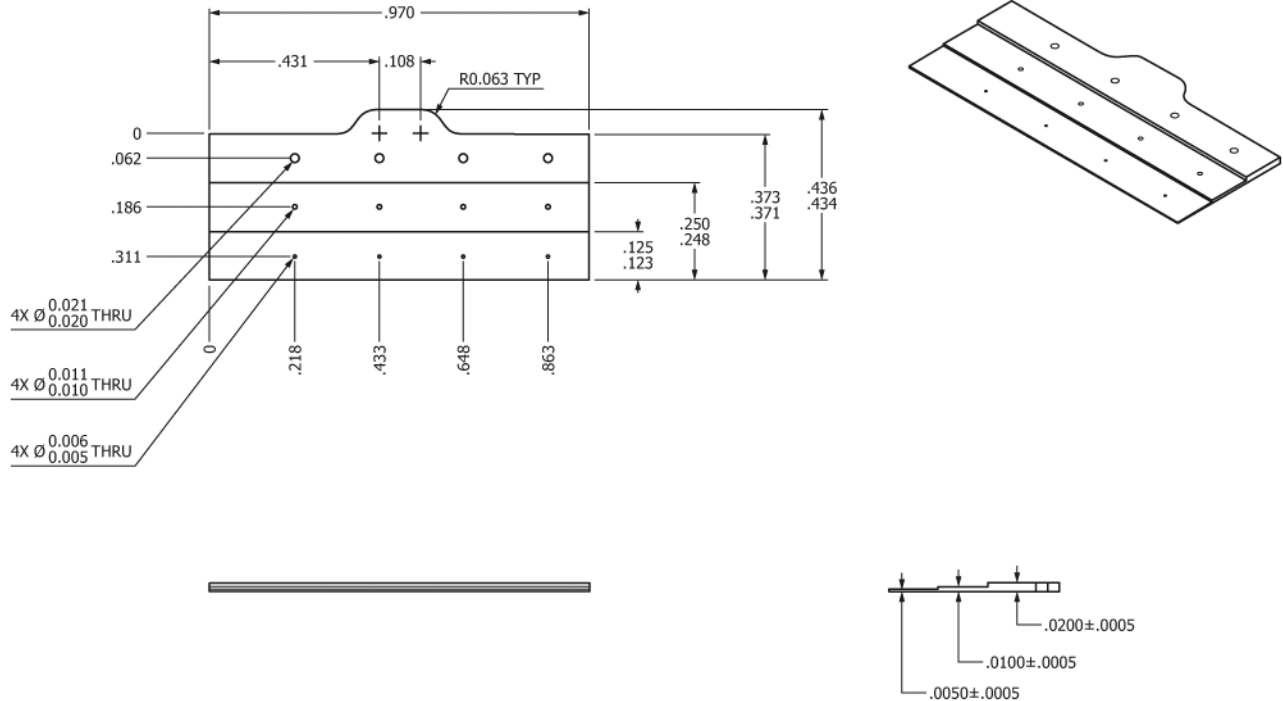

NOTE 1—The tab geometry may vary as needed for machining. The exact size and shape are not relevant to the device’s function.

FIG. 4 Shim

may be prepared from aluminum shim stock, 0.012 in. thick by 1.50 in.<sup>2</sup> by cutting out a 0.250 in.<sup>2</sup> from each corner and folding the aluminum to form a cover, 1 in.<sup>2</sup> by 0.250 in. high (see Fig. 1).

8.2 Assembly:

8.2.1 Insert the shim into the aluminum block (see Fig. 5).

8.2.2 Insert a 0.125 in. methylmethacrylate strip (previously prepared in 8.1.7) into the channel so that the second strip is positioned over Shim C. Over Channel D, insert a 0.125 in. methylmethacrylate strip (see Fig. 6).

8.2.3 Insert the 0.010 in. thick aluminum strip next to the methylmethacrylate strip between the B and C channels (see Fig. 6).

8.2.4 Insert another 0.125 in. methylmethacrylate strip next to the aluminum strip (see Fig. 6).

8.2.5 Insert the 0.005 in. thick aluminum strip (see Fig. 6).

8.2.6 Insert the last 0.125 in. methylmethacrylate strip next to the previously inserted aluminum strip (see Fig. 6).

8.2.7 Insert the 0.0005 in. thick aluminum strip next to the previously inserted methylmethacrylate strip (see Fig. 6).

8.2.8 Insert a 0.060 in. thick methylmethacrylate strip next to the previously inserted aluminum strip (see Fig. 6).

8.2.9 Repeat the steps described in 8.2.7 and 8.2.8, alternating increasing aluminum strip thickness with 0.060 in. thick methylmethacrylate strips (see Fig. 6), that is:

- 0.001 in. thick aluminum strip
- 0.060 in. thick methylmethacrylate strip
- 0.002 in. thick aluminum strip
- 0.060 in. thick methylmethacrylate strip
- 0.003 in. thick aluminum strip
- 0.060 in. thick methylmethacrylate strip
- 0.004 in. thick aluminum strip
- 0.060 in. thick methylmethacrylate strip