



Designation: C1197—20^{ε1} C1197 – 22

Standard Test Method for In Situ Measurement of Masonry Deformability Properties Using the Flatjack Method¹

This standard is issued under the fixed designation C1197; the number immediately following the designation indicates the year of original adoption or, in the case of revision, the year of last revision. A number in parentheses indicates the year of last reappraisal. A superscript epsilon (ϵ) indicates an editorial change since the last revision or reappraisal.

^{ε1} NOTE—Summary of Changes section was editorially updated in January 2021.

1. Scope*

1.1 This test method describes an in situ method for determining the deformation properties of existing unreinforced solid-unit masonry. (See [Note 1](#).) This test method concerns the measurement of in-situ masonry deformability properties in existing masonry by use of thin, bladder-like flatjack devices that are installed in cut mortar joints in the masonry wall. This test method provides a relatively non-destructive means of determining masonry properties.

NOTE 1—Solid-unit masonry is that built with stone, concrete, or clay units whose net area is equal to or greater than 75 % of the gross area.

1.2 The text of this standard refers to notes and footnotes that provide explanatory material. These notes and footnotes (excluding those in tables and figures) shall not be considered as requirements of the standard.

1.3 The values stated in inch-pound units are to be regarded as standard. The values given in parentheses are mathematical conversions to SI units that are provided for information only and are not considered standard.

1.4 *This standard does not purport to address all of the safety concerns, if any, associated with its use. It is the responsibility of the user of this standard to establish appropriate safety, health, and environmental practices and determine the applicability of regulatory limitations prior to use.*

1.5 *This international standard was developed in accordance with internationally recognized principles on standardization established in the Decision on Principles for the Development of International Standards, Guides and Recommendations issued by the World Trade Organization Technical Barriers to Trade (TBT) Committee.*

2. Referenced Documents

2.1 *ASTM Standards:*²

[C1180 Terminology of Mortar and Grout for Unit Masonry](#)

[C1232 Terminology for Masonry](#)

[E74 Practices for Calibration and Verification for Force-Measuring Instruments](#)

3. Terminology

3.1 *Definitions of Terms Specific to This Standard:*

¹ This test method is under the jurisdiction of ASTM Committee C15 on Manufactured Masonry Units and is the direct responsibility of Subcommittee C15.04 on Research. Current edition approved Dec. 15, 2020/Dec. 1, 2022. Published December 2020/December 2022. Originally approved in 1992. Last previous edition approved in 2014/2020 as C1197—14a/C1197 – 20^{ε1}. DOI: 10.1520/C1197-20E01; 10.1520/C1197-22.

² For referenced ASTM standards, visit the ASTM website, www.astm.org, or contact ASTM Customer Service at service@astm.org. For *Annual Book of ASTM Standards* volume information, refer to the standard's Document Summary page on the ASTM website.

*A Summary of Changes section appears at the end of this standard

3.1.1 *shim, n*—item inserted into a flatjack slot prior to testing to minimize the inflation of the test flatjack.

3.1.1.1 *Discussion*—

The use of shims may be necessary during testing to achieve a tight fit of the flatjack in the slot and to ensure uniform transfer of pressure (stress) to the masonry over the complete area of the flatjack. See Annex A1 for further discussion on allowable types of shims.

3.1.2 *spacer, n*—metal plate used in the calibration process to control flatjack thickness.

3.2 For definitions of other terms used in this test method refer to Terminology C1180 for mortar and grout and Terminology C1232 for masonry.

4. Summary of Test Method

4.1 Two flatjacks inserted into parallel slots, one above the other, in a solid-unit masonry wall are pressurized thus inducing compressive stress on the masonry between them. The installation is shown in Fig. 1. By gradually increasing the flatjack pressure and measuring the deformation of the masonry between the flatjacks, load-deformation (stress-strain) properties may be obtained. Maximum compressive strengths may be measured in certain cases.

5. Significance and Use

5.1 Deformation and strength properties are measured only on the masonry between flatjacks. Boundary effects of the collar joint behind the wythe tested and adjacent masonry are neglected. In the case of multi-wythe masonry, deformability is estimated only in the wythe in which the flatjack is inserted. Deformability of other wythes may be different.

6. Apparatus

6.1 *Flatjack:*

6.1.1 A flatjack is a thin envelope-like bladder with inlet and outlet ports which may be pressurized with hydraulic fluid. Flatjacks may be of any shape in plan, and are designed to be compatible with the masonry being tested. For determining load-deformation properties of masonry, flatjacks are typically rectangular or semi-rectangular as shown in Fig. 2.

6.1.2 For determination of the state of compressive stress, dimension A should be equal to or greater than the length of a single masonry unit, but not less than 8 in. (200 mm). Dimension B should be equal to or greater than the thickness of one wythe and not less than 3 in. (75 mm). The radius, R, for circular and semi-rectangular flatjacks shall be equal to the radius of the circular saw blade used to cut the slot.

6.1.3 Flatjacks shall be made of metal or other material such that the flatjack in a slot in masonry will be capable of applying operating pressures up to the expected maximum flatjack pressure. See Notes 2 and 3. The flatjack fabricator shall provide the manufactured undeformed thickness for each flatjack. Fig. 3 shows examples of manufactured undeformed thicknesses.

NOTE 2—Metal flatjacks suitable for this purpose have successfully been made of type 304 stainless steel sheet of 0.024 (0.6 mm) to 0.048 in. (1.2 mm) in thickness with welded seams along the edges, and incorporating hydraulic inlet or outlet ports.

NOTE 3—A maximum operating pressure of 1000 psi (6.9 MPa) is adequate for most older existing masonry, but flatjacks with higher operating pressures

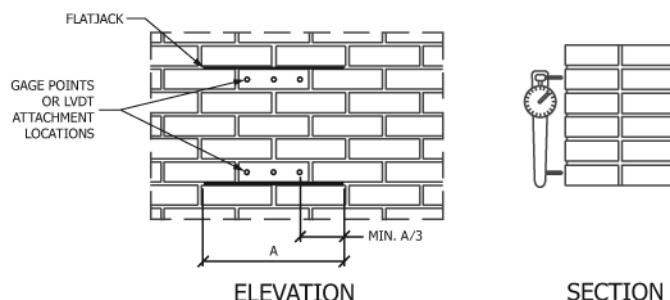

FIG. 1 Deformation Properties Using Two Flatjacks

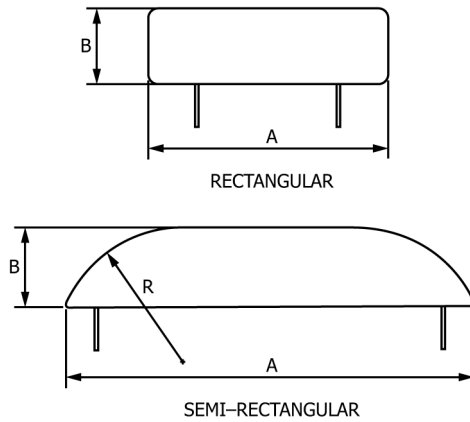

FIG. 2 Flatjack Configurations (Plan View)

are available for higher strength masonry, often found in more recently constructed buildings. Flatjacks manufactured with flexible polymers that have operating pressure ranges of less than 1000 psi (6.9 MPa) may be useful for stress measurements in some historic masonry.

6.1.4 Calibrate all flatjacks as described in Section 8 to determine their pressure-applied load characteristics.

6.2 *Hydraulic System*—A hydraulic pump with hydraulic hoses is required. Hose connections shall fit the flatjack inlet port. Measure pressure using gauges calibrated to a traceable standard having both an accuracy of 1 % of full hydraulic scale and an appropriate operating range. The hydraulic system shall be capable of maintaining constant pressure within 1 % of full scale for at least 5 min.

6.3 *Displacement Measurement*—Measure displacements of the masonry with electronic instrumentation, for example, a Linearly Variable Differential Transformer (LVDT) mounted to the surface of the masonry between the flatjacks, or by a mechanical gauge extensometer which measures the distance between fixed gauge points on the masonry as shown in Fig. 1. The method or device used to measure deformations shall be capable of deformation measurements up to $\frac{3}{16}$ in. (5 mm). Deformation measurements shall have an accuracy of at least ± 0.005 % of gauge length. Record measurements manually at discrete intervals, or continuously by automatic data recording.

6.4 *Attachment of Measurement Devices*—Attach brackets for mounting electrical displacement measuring devices or gauge points to be used with mechanical devices securely to the surface of the masonry to prevent movement and ensure the required measurement accuracy. Use rigid adhesive for discs and brackets and cementitious grout for plugs. If gauge points are used, the gauge points shall have a conical depression at their center, compatible with the pointed elements of the extensometer. The angles of the depression of the cone and the extensometer points shall be the same.

7. Preparation of Slots

7.1 Slots in masonry are normally prepared by removing the mortar from masonry bed joints to avoid disfiguring the masonry. Remove all mortar in the bed joint, that is, pressure exerted by a flatjack shall be directly against the surfaces of the masonry units.

7.2 The plan geometry of the slot shall be similar to that of the flatjack being used. Plan dimensions of the prepared slot shall not exceed those of the flatjack by more than $\frac{1}{2}$ in. (12 mm). Slots shall be parallel and aligned vertically, and shall be separated by not more than 1.5 times the length of the flatjack.

7.3 Prepare rectangular slots into which rectangular flatjacks are to be inserted by drilling adjacent or overlapping holes (stitch drilling) and subsequently using a drill, bar, or tool to remove mortar and produce a slot of desired dimensions with smooth upper and lower surfaces. Other tools, such as oscillating blade grinders, that can be reliably used to form rectangular slots in masonry mortar joints without damaging the surrounding masonry are also permitted to be used.

7.4 Prepare slots for circular and semi-rectangular flatjacks using circular saws of sufficient radius to provide the depth required (Fig. 2, dimension B). Use carbide or diamond tipped blades to remove all mortar from the slot.

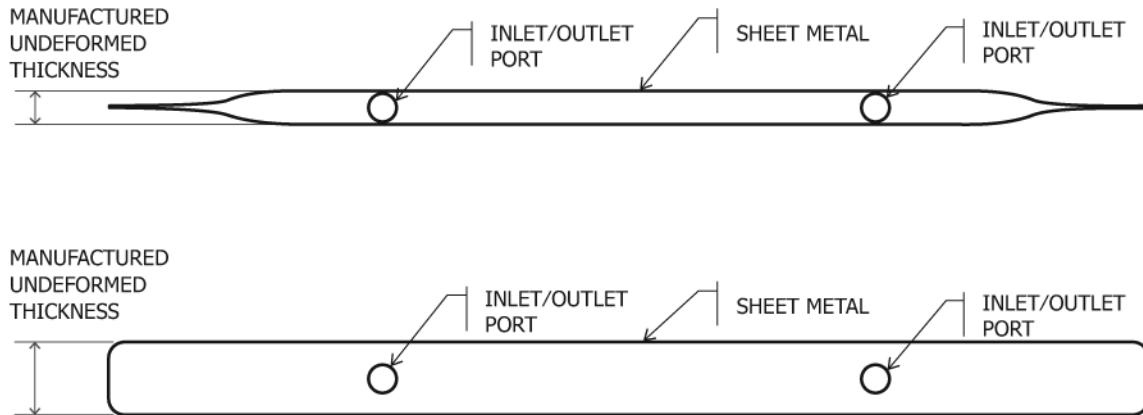

FIG. 3 Schematic Section Diagram of Two Types of Flatjacks Showing Examples of Manufactured Undeformed Thicknesses

8. Calibration

8.1 A flatjack has an inherent stiffness which resists expansion when the jack is pressurized. Therefore, the fluid pressure in the flatjack is greater than the stress the flatjack applies to masonry. A flatjack must be calibrated to provide a conversion factor, K_m , to relate internal fluid pressure to applied stress.

8.2 Calibrate flatjacks in a compression machine of at least 100 kip (450 kN) capacity which has been calibrated according to Practice E74.

8.3 Place a 2 in. (50 mm) thick steel bearing plate on the lower platen of the compression machine. The bearing plate shall be of sufficient size to completely cover the flatjack being calibrated. Place the flatjack on the lower bearing plate such that the edge of the flatjack with the inlet/outlet ports is coincident with the edge of the bearing plate. Place steel spacers around the other edges of the flatjack. The thickness of the spacers shall be 0.015 to 0.050 in. (0.38 to 1.27 mm) greater than the manufactured undeformed thickness of the flatjack (see Fig. 3). Place the upper 2 in. (50 mm) thick bearing plate on top of the spacers and flatjack, and align it to be directly above the lower bearing plate. Position the bearing plate/flatjack/spacer assembly on the lower platen such that the centroid of the area of the flatjack is within 1/4 in. (6 mm) of the axis of thrust of the test machine. The calibration setup is illustrated in Fig. 4.

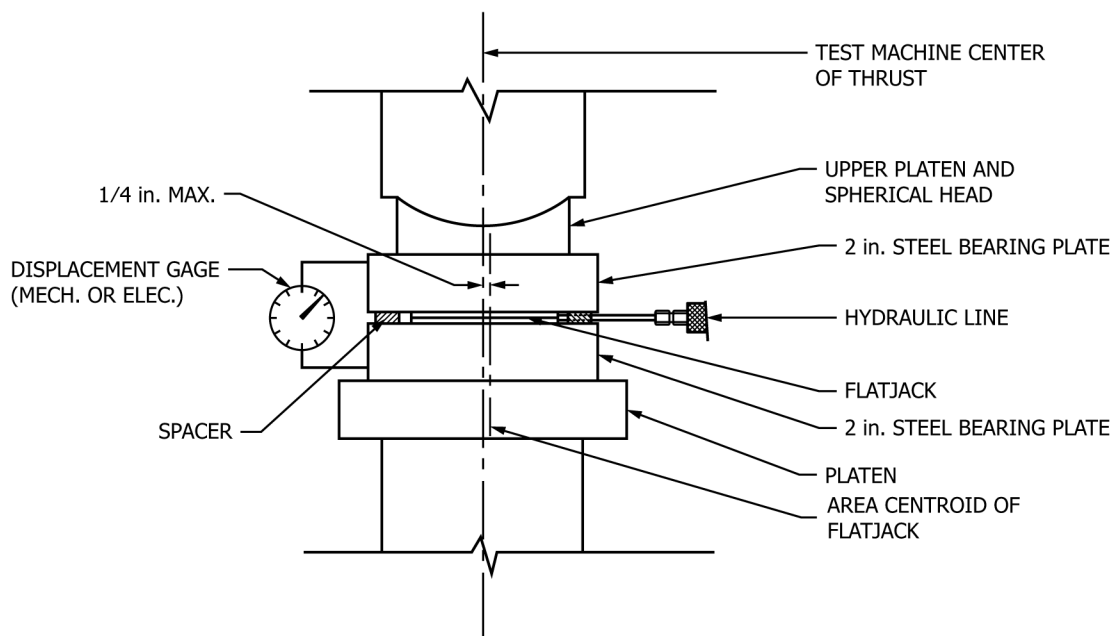

FIG. 4 Flatjack Calibration Setup (Elevation View)

8.4 Raise or lower the moveable platen such that both platens are in contact with the bearing plates. Apply a pre-load sufficient to provide full contact between the bearing plates and the spacers, equivalent to 10 psi (0.07 MPa) over the gross area of the flatjack.

8.5 The distance between platens must be held constant during the calibration procedure. Fix the displacement of the test machine at this point if using a displacement-control machine. If not, attach displacement gauges (mechanical or electrical) such that the distance between platens established by the procedures of paragraph 8.4 can be held constant when using a force-control test machine.

8.6 Pressurize and depressurize the flatjack three times over the full operating pressure range. Do not exceed the maximum flatjack operating pressure.

8.6.1 While holding the distance between the platens constant, increase the pressure in the flatjack in equal increments to within 5 percent of the maximum flatjack operating pressure. Use at least 10 equal increments between 0 psi and the maximum flatjack operating pressure. At each increment, record flatjack hydraulic pressure and force applied by the test machine.

8.7 Calculate the load applied by the flatjack as internal pressure times gross flatjack area. Plot flatjack load versus load measured by the test machine with the flatjack load on the horizontal axis of the plot. The slope of the line equals the flatjack constant, that is, the conversion factor:

$$K_m = P_{\text{machine}} \div P_{\text{flatjack}} \quad (1)$$

8.8 Recalibrate flatjacks after using five times or when distortion appears excessive.

9. Procedure

9.1 The location where masonry deformability estimates are conducted is dictated by engineering objectives. The basic arrangement is illustrated in Fig. 1. At the desired location or locations take the following steps should be taken steps.

9.2 Select and mark a visible line on the masonry to define the location and length of slots to be formed.

9.3 Prepare the slots (see Note 4) (see Section 7) and record the measured slot dimensions. Clean slots of all mortar and brick particles prior to the insertion of flatjacks. Slots shall be separated by at least five courses of masonry, but not more than 1.5 times the length of the flatjack.

NOTE 4—The location of the slots ~~shall~~ should be at least 1½ flatjack lengths from wall openings or ends. There should be sufficient masonry above the top slot to resist forces developed during pressurization of the flatjacks.

9.4 Attach at least three equally spaced pairs of gauge points or electrical measuring devices as shown in Fig. 1. Center measurement points vertically between flatjacks, with a minimum gauge length of 8 in. Locate the measurement points on masonry units, not at mortar joints. The first and last measurement points ~~should~~ shall be located at least a distance $A/8/3$ in from the ends of the slot, where A is the flatjack length as shown in Fig. 2.

9.5 Insert the flatjack into the slot. Shim, as required, to achieve a tight fit and bridge over any interior voids in the masonry. See Annex A1 for a description of flatjack shims and their use.

9.6 Connect hydraulic hoses and fill the flatjacks with hydraulic fluid until pressure begins to develop.

9.7 In order to seat the flatjack and any shims, pressurize the flatjack to approximately 50 % of the estimated maximum flatjack pressure (which corresponds to the estimated maximum compressive strength of the masonry). Reduce the flatjack pressure to zero.

9.8 Take initial measurements with mechanical devices (three repetitions) or initialize electrical devices.

9.9 Increase pressure slowly. Take displacement measurements at small increments of pressure. If measurements are to be taken