



Designation: ~~D5863–00a (Reapproved 2016)~~ D5863 – 22

Standard Test Methods for Determination of Nickel, Vanadium, Iron, and Sodium in Crude Oils and Residual Fuels by Flame Atomic Absorption Spectrometry¹

This standard is issued under the fixed designation D5863; the number immediately following the designation indicates the year of original adoption or, in the case of revision, the year of last revision. A number in parentheses indicates the year of last reapproval. A superscript epsilon (ϵ) indicates an editorial change since the last revision or reapproval.

1. Scope Scope*

1.1 These test methods cover the determination of nickel, vanadium, iron, and sodium in crude oils and residual fuels by flame atomic absorption spectrometry (AAS). Two different test methods are presented.

1.2 ~~Test Method Procedure A, Sections 78–1314~~—Flame AAS is used to analyze a sample that is decomposed with acid for the determination of total Ni, V, and Fe.

1.3 ~~Test Method Procedure B, Sections 1415–1920~~—Flame AAS is used to analyze a sample diluted with an organic solvent for the determination of Ni, V, and Na. This test method uses oil-soluble metals for calibration to determine dissolved metals and does not purport to quantitatively determine nor detect insoluble particulates. Hence, this test method may underestimate the metal content, especially sodium, present as inorganic sodium salts.

1.4 The concentration ranges covered by these test methods are determined by the sensitivity of the instruments, the amount of sample taken for analysis, and the dilution volume. A specific statement is given in **Note 1**.

<https://standards.iteh.ai/catalog/standards/sist/ac5a1a43-fcbe-46ab-a844-2bd064c3f4f0/astm-d5863-22>

1.5 For each element, each test method has its own unique precision. The user can select the appropriate test method based on the precision required for the specific analysis.

1.6 The values stated in SI units are to be regarded as standard. No other units of measurement are included in this ~~standard~~ standard, unless specifically stated. Other units that appear in this standard are included for information purposes only or because they are in embedded pictures that cannot be edited.

1.7 *This standard does not purport to address all of the safety concerns, if any, associated with its use. It is the responsibility of the user of this standard to establish appropriate ~~safety~~ safety, health, and ~~health~~ environmental practices and determine the applicability of regulatory limitations prior to use.* Specific warning statements are given in ~~7-18.1, 8-29.2, 8-59.5, 10-211.2, 10-411.4, and 15-116.1~~.

1.8 *This international standard was developed in accordance with internationally recognized principles on standardization established in the Decision on Principles for the Development of International Standards, Guides and Recommendations issued by the World Trade Organization Technical Barriers to Trade (TBT) Committee.*

¹ These test methods are under the jurisdiction of ASTM Committee D02 on Petroleum Products, Liquid Fuels, and Lubricants and are the direct responsibility of Subcommittee D02.03 on Elemental Analysis.

Current edition approved April 1, 2016 Dec. 1, 2022. Published May 2016 January 2023. Originally approved in 1995. Last previous edition approved in 2014 2016 as D5863 – 00a (2014) (2016). DOI: 10.1520/D5863-00AR16–10.1520/D5863-22.

*A Summary of Changes section appears at the end of this standard

2. Referenced Documents

2.1 ASTM Standards:²

[D1193 Specification for Reagent Water](#)

[D4057 Practice for Manual Sampling of Petroleum and Petroleum Products](#)

[D4175 Terminology Relating to Petroleum Products, Liquid Fuels, and Lubricants](#)

[D4177 Practice for Automatic Sampling of Petroleum and Petroleum Products](#)

[D6299 Practice for Applying Statistical Quality Assurance and Control Charting Techniques to Evaluate Analytical Measurement System Performance](#)

3. Terminology

3.1 Definitions:

3.1.1 For definitions of terms used in these test methods, refer to Terminology [D4175](#).

4. Summary of Test Method

4.1 *Test Method Procedure A*—One to twenty grams of sample are weighed into a beaker and decomposed with concentrated sulfuric acid by heating to dryness. The residual carbon is burned off by heating at 525 °C in a muffle furnace. The inorganic residue is digested in dilute nitric acid, evaporated to incipient dryness, dissolved in dilute nitric and made up to volume with dilute nitric acid. Interference suppressant is added to the dilute nitric acid solution. The solution is nebulized into the flame of an atomic absorption spectrometer. A nitrous oxide/acetylene flame is used for vanadium and an air/acetylene flame is used for nickel and iron. The instrument is calibrated with matrix-matched standard solutions. The measured absorption intensities are related to concentrations by the appropriate use of calibration data.

4.2 *Test Method Procedure B*—Sample is diluted with an organic solvent to give a test solution containing either 5 % (m/m) or 20 % (m/m) sample. The recommended sample concentration is dependent on the concentrations of the analytes in the sample. For the determination of vanadium, interference suppressant is added to the test solution. The test solution is nebulized into the flame of an atomic absorption spectrometer. A nitrous oxide/acetylene flame is used for vanadium and an air/acetylene flame is used for nickel and sodium. The measured absorption intensities are related to concentrations by the appropriate use of calibration data.

5. Significance and Use

5.1 When fuels are combusted, metals present in the fuels can form low melting compounds that are corrosive to metal parts. Metals present at trace levels in petroleum can deactivate catalysts during processing. These test methods provide a means of quantitatively determining the concentrations of vanadium, nickel, iron, and sodium. Thus, these test methods can be used to aid in determining the quality and value of the crude oil and residual oil.

6. Purity of Reagents

6.1 Reagent grade chemicals shall be used for all tests. Unless otherwise indicated, it is intended that all reagents conform to the specifications of the Committee on Analytical Reagents of the American Chemical Society where such specifications are available.³ Other grades may be used, provided it is first ascertained that the reagent is of sufficiently high purity to permit its use without lessening the accuracy of the determination.

6.2 When determining metals at concentrations less than 1 mg/kg, use ultra-pure grade reagents.

6.3 *Purity of Water*—Unless otherwise indicated, reference to water shall be understood to mean reagent water conforming to Type II of Specification [D1193](#).

² For referenced ASTM standards, visit the ASTM website, www.astm.org, or contact ASTM Customer Service at service@astm.org. For *Annual Book of ASTM Standards* volume information, refer to the standard's Document Summary page on the ASTM website.

³ *Reagent Chemicals, American Chemical Society Specifications*; *ACS Reagent Chemicals, Specifications and Procedures for Reagents and Standard-Grade Reference Materials*, American Chemical Society, Washington, DC. For suggestions on the testing of reagents not listed by the American Chemical Society, see *Analar Standards for Laboratory Chemicals*, BDH Ltd., Poole, Dorset, U.K., and the *United States Pharmacopeia and National Formulary*, U.S. Pharmacopeial Convention, Inc. (USPC), Rockville, MD.

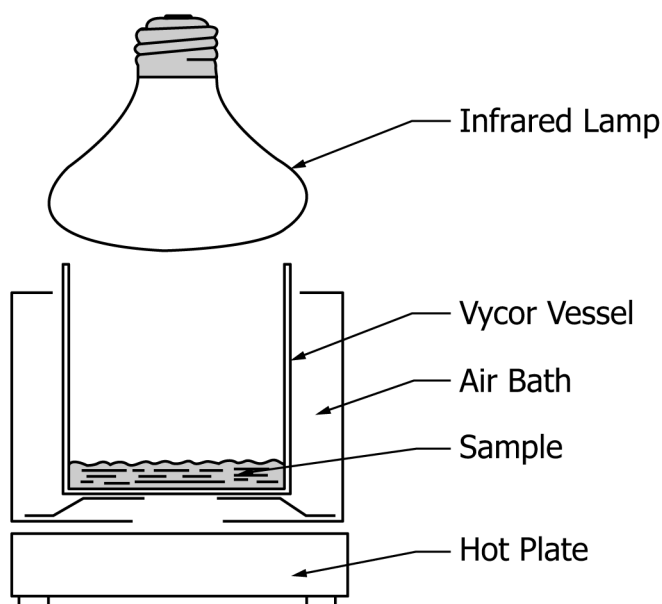

FIG. 1 Decomposition Apparatus

7. Sampling and Sample Handling

7.1 The objective of sampling is to obtain a sample for testing purposes that is representative of the entire quantity. Only representative samples obtained as specified in Practices D4057 and D4177 shall be used. Do not fill the sample container more than two-thirds full.

7.2 Prior to weighing, stir the sample and then shake the sample in its container. If the sample does not readily flow at room temperature, heat the sample to a sufficiently high and safe temperature to ensure adequate fluidity.

TEST METHOD PROCEDURE A—FLAME ATOMIC ABSORPTION AFTER ACID DECOMPOSITION OF THE SAMPLE

8. Apparatus

8.1 *Atomic Absorption Spectrometer*, complete instrument with hollow cathode lamps and burners with gas supplies to support air-acetylene and nitrous oxide-acetylene flames. (**Warning**—Hazardous. Potentially toxic and explosive. Refer to the manufacturer's instrument manual for associated safety hazards.)

8.2 *Sample Decomposition Apparatus (optional)*—This apparatus is described in Fig. 1. It consists of a borosilicate glass 400 mL beaker for the test solution, an air bath (Fig. 2) that rests on a hot plate and a 250 W infrared lamp supported 2.5 cm above the air bath. A variable transformer controls the voltage applied to the lamp.

8.3 *Glassware*—Borosilicate glass 400 mL beakers, volumetric flasks of various capacities and pipettes of various capacities. When determining concentrations below 1 mg/kg, all glassware must be thoroughly cleaned (or soaked overnight) with 5 % HNO₃ and rinsed five times with water.

8.4 *Electric Muffle Furnace*, capable of maintaining 525 °C ± 25 °C and sufficiently large to accommodate 400 mL beakers. The capability of an oxygen bleed is advantageous and optional.

8.5 *Steam Bath*.

8.6 *Temperature Controlled Hot Plate*, (optional).

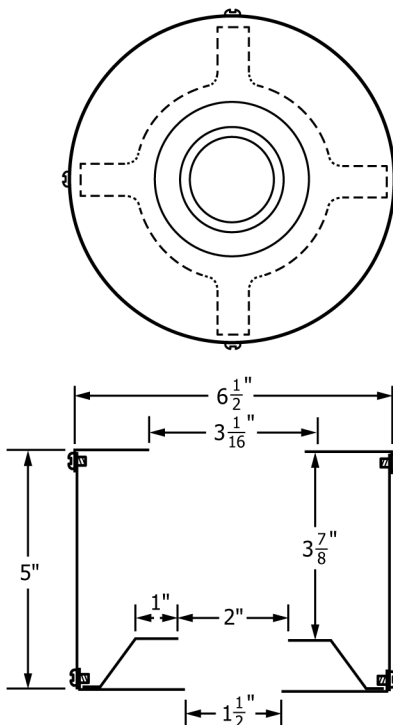

NOTE 1—All parts 16 gage (1.5 mm, 0.060 in.) aluminum. All dimensions are in inches.

iTeh Standards
(<https://standards.itih.ai>)
Document Preview

Metric Equivalents

in.	mm	in.	mm
1	25.4	3/8	98.4
1 1/2	38.1	5	127
2	50.8	6 1/2	165.1
3 1/16	77.8

ASTM D5863-22
FIG. 2 Air Bath

<https://standards.itih.ai/catalog/standards/sist/ac5a1a43-fc9c-46ab-a844-2bd064c3f4f0/astm-d5863-22>

8.7 *Drying Oven*, (optional), explosion-proof, if used to heat crude oils to obtain fluidity.

9. Reagents

9.1 *Aqueous Standard Solutions*—Individual aqueous standards with 1000 mg/kg concentrations of vanadium, nickel, and iron, purchased or prepared in acid matrix to ensure stability.

9.2 *Nitric Acid*—Concentrated nitric acid, HNO₃. (**Warning**—Poison, oxidizer. Causes severe burns. Harmful or fatal if swallowed or inhaled.)

9.3 *Nitric Acid 50 % (V/V)*—Carefully add, with stirring, one volume of concentrated nitric acid to one volume of water.

9.4 *Dilute Nitric Acid, 5 % (V/V)*—Carefully add, with stirring, one volume of concentrated nitric acid to 19 volumes of water.

9.5 *Sulfuric Acid*—Concentrated sulfuric acid, H₂SO₄. (**Warning**—Poison, oxidizer. Causes severe burns. Harmful or fatal if swallowed or inhaled.)

9.6 *Aluminum Nitrate*, Al(NO₃)₃ 9HOH.

TABLE 1 AAS Conditions for the Determination of Vanadium, Nickel, and Iron Following Acid Sample Decomposition

Element	Wavelength, nm	Concentration Range, µg/mL	Interference Suppressant	Flame
Vanadium	318.4	0.5–20	250 µg/mL Al, Al(NO ₃) ₃ in 5 % (V/V) HNO ₃	N ₂ O-C ₂ H ₂
Nickel	232.0	0.5–20	None	Air-C ₂ H ₂
Iron	248.3	3.0–10	None	Air-C ₂ H ₂

9.7 Potassium Nitrate, KNO₃.

10. Preparation of Standards

10.1 *Multi-Element Standard*—Using the aqueous standard solutions, prepare a multi-element standard containing 100 mg/kg each of vanadium, nickel, and iron. Standards should be prepared to ensure accuracy and stability and should be stored in clean containers to safeguard against physical degradation.

10.2 *Working Standards*—Prepare at least two working standards to cover the concentration ranges specified in Table 1. For vanadium, add the specified interference suppressant. Each working standard must contain 5 % (V/V) nitric acid. Standards should be prepared to ensure accuracy and stability and should be stored in clean containers to safeguard against physical degradation.

10.3 *Standard Blank*, the standard blank contains 5 % (V/V) nitric acid and any interference suppressant specified in Table 1.

10.4 *Check Standard*—Prepare a calibration check standard in the same way as the working standards and at analyte concentrations that are typical of the specimens being analyzed.

11. Preparation of Test Solutions

11.1 Into a beaker, weigh an amount of sample estimated to contain between 0.0025 mg and 0.12 mg of each metal to be determined. A typical mass is 10 g. Add 0.5 mL of H₂SO₄ for each gram of sample.

NOTE 1—If it is desired to extend the lower concentration limits of the test method, it is recommended that the decomposition be done in 10 g increments up to a maximum of 100 g. It is not necessary to destroy all the organic matter each time before adding additional amounts of the sample and acid. When it is desired to determine higher concentrations, reduce the sample size accordingly.

11.2 At the same time prepare reagent blanks using the same amount of sulfuric acid as used for sample decomposition. Reagent blanks should be carried through the same procedure as the samples. (**Warning**—Reagent blanks are critical when determining concentrations below 1 mg/kg. To simplify the analysis, use the same volume of acid and the same dilutions as used for the samples. For example, if 20 g of sample is being decomposed, use 10 mL of sulfuric acid for the reagent blank.)

11.3 The use of the air bath apparatus (Fig. 2) is optional. Place the beaker in the air bath, which is located in the hood. The hot plate is off at this time. Heat gently from the top with the infrared lamp (Fig. 1) while stirring the test solution with a glass rod. As decomposition proceeds (indicated by a frothing and foaming), control the heat of the infrared lamp to maintain steady evolution of fumes. Give constant attention to each sample mixture until all risk of spattering and foaming is past. Then, gradually increase the temperature of both the hot plate and lamp until the sample is reduced to a carbonaceous ash.

11.4 If the air bath apparatus is not used, heat the sample and acid on a temperature controlled hot plate. As described in 10.311.3, monitor the decomposition reaction and adjust the temperature of the hot plate accordingly. (**Warning**—Hot fuming concentrated sulfuric acid is very corrosive and a strong oxidizing acid. The analyst should work in a well-ventilated hood and wear rubber gloves and a suitable face shield to protect against spattering acid.)

11.5 Place the sample in the muffle furnace maintained at 525 °C ± 25 °C. Optionally, introduce a gentle stream of oxygen into the furnace to expedite oxidation. Continue to heat until the carbon is completely removed.

11.6 Dissolve the inorganic residue by washing down the wall of the beaker with about 10 mL of the 1 + 1 HNO₃. Digest on a steam bath for 15 min to 30 min. Transfer to a hot plate and gently evaporate to incipient dryness.

11.7 Wash down the wall of the beaker with about 10 mL of dilute nitric acid (5 % V/V). Digest on the steam bath until all salts are dissolved. Allow to cool. Transfer quantitatively to a volumetric flask of suitable volume and make up to volume with dilute nitric acid. This is the test solution.

11.8 Pipette aliquots of the test solution into two separate volumetric flasks. Retain one flask for the determination of nickel and iron. To the other flask add aluminum interference suppressant for vanadium determination (refer to **Table 1**) and dilute up to mark with dilute nitric acid (5 % V/V). Similarly, prepare a reagent blank solution for vanadium analysis.

12. Preparation of Apparatus

12.1 Consult the manufacturer's instructions for the operation of the atomic absorption spectrometer. This test method assumes that good operating procedures are followed. Design differences between spectrometers make it impractical to exactly specify required instrument settings.

12.2 Set up the instrument to determine each analyte sequentially.

13. Calibration and Analysis

13.1 For each analyte in turn, perform the following operation:

13.2 Nebulize the appropriate standard and zero the instrument.

13.3 Nebulize the working standards, determine the absorbance and construct a calibration curve of absorbance versus analyte concentration utilizing the instrument's concentration mode if available, otherwise plot these values.

13.4 Use the check standard to determine if the calibration for each analyte is accurate. If the results obtained on the check standard are not within $\pm 5\%$ of the expected concentration for each analyte, take corrective action and repeat the calibration.

13.5 Nebulize the test solutions and measure and record the absorbance. If appropriate, blank correct this absorbance by subtracting the reagent blank absorbance.

13.6 After measuring absorbances for a test solution, check the blank standard. If this does not read zero, check the system, and then repeat steps ~~12.2~~13.2 – ~~12.5~~13.5.

13.7 Test solutions that give absorbances greater than that obtained with the most concentrated working standard must be diluted. The dilution must contain interference suppressant at the specified concentrations.

14. Quality Assurance/Quality Control (QA/QC)

14.1 Confirm the performance of the instrument and the test procedure by analyzing a control QC sample.

14.1.1 When QA/QC protocols are already established in the testing facility, these may be used to confirm the reliability of the test result.

14.1.2 When there is no QA/QC protocol established in the testing facility, **Appendix X1** can be used as the QA/QC protocol.

14.2 Users of this test method are advised that in contractual agreements, one or more of the contracting parties can and may make **Appendix X1** a mandatory practice.

TABLE 2 AAS Conditions for the Determination of Vanadium, Nickel, and Sodium Following Solvent Dilution of the Sample

Element	Wavelength, nm	Concentration Range, mg/kg	Interference Suppressant	Flame
Vanadium	318.4	0.5–15	15 mg/kg Al ^A	N ₂ O-C ₂ H ₂
Nickel	232.0	0.5–20	None	Air-C ₂ H ₂
Sodium	589.0	0.1–5	None	Air-C ₂ H ₂

^A Prepared from an organometallic standard, mineral oil, and dilution solvent.

TEST METHOD PROCEDURE B—FLAME ATOMIC ABSORPTION WITH AN ORGANIC SOLVENT TEST SOLUTION

15. Apparatus

15.1 Refer to Section [7.18.1](#).

15.2 *Test Solution Containers*—Glass or plastic vials or bottles, with screw caps and a capacity of between 50 mL to 100 mL. Glass bottles of 100 mL capacity are satisfactory.

16. Reagents

16.1 *Dilution Solvent*—Mixed xylenes, o-xylene, tetralin and mixed paraffin-aromatic solvents are satisfactory. (**Warning**—Combustible. Vapor harmful.) Solvent purity can affect analytical accuracy when the sample contains low concentrations (typically, a few mg/kg) of the analytes.

16.2 *Mineral Oil*—A high-purity oil such as U.S.P. white oil.

16.3 *Organometallic Standards*—Pre-prepared multi-element concentrates containing 100 mg/kg concentrations of each element are satisfactory.⁴

17. Preparation of Standards and Test Solutions [ASTM D5863-22](#)

<https://standards.iteh.ai/catalog/standards/sist/ac5a1a43-fc8c-46ab-a844-2bd064c3f4f0/astm-d5863-22>

17.1 *Test Solution*—Weigh a portion of well-mixed sample into a container and add solvent to achieve a sample concentration of either 5 % (m/m) or 20 % (m/m). Mix well. If the concentration of V, Ni, or Na in the sample exceeds 20 mg/kg, the analysis for that element is performed on a test solution containing 5 % (m/m) sample. For concentrations less than 20 mg/kg, the analysis for that element is performed on a test solution that contains 20 % (m/m) sample.

17.2 *Standards*—If the test solution contains 5 % (m/m) sample, then the corresponding working standards and check standard must contain 5 % (m/m) oil. Similarly, if the test solution contains 20 % (m/m) sample, the standards must contain 20 % (m/m) oil. A consistent dilution factor is necessary so that all aspirated samples and standards will have the same viscosity. This is essential to obtain consistent uptake rates.

17.2.1 *Working Standards*—Prepare a blank (from mineral oil) and three additional working standards (from the organometallic standards) that cover the ranges of concentration specified in [Table 2](#).

17.2.2 *Check Standard*—Using the organometallic standards, mineral oil, and dilution solvent, prepare a check standard to contain analyte concentrations approximately the same as expected in the test solutions.

18. Preparation of Apparatus

18.1 Refer to Section [4.12](#).

⁴ The sole source of supply of the standards known to the committee at this time is Conoco, Inc., Conostan Division, P.O. Box 1269, Ponca City, OK 74602. If you are aware of alternative suppliers, please provide this information to ASTM International Headquarters. Your comments will receive careful consideration at a meeting of the responsible technical committee,¹ which you may attend.