



Designation: **D7006–03 (Reapproved 2022) D7006 – 22**

Standard Practice for Ultrasonic Testing of Geomembranes¹

This standard is issued under the fixed designation D7006; the number immediately following the designation indicates the year of original adoption or, in the case of revision, the year of last revision. A number in parentheses indicates the year of last reapproval. A superscript epsilon (ϵ) indicates an editorial change since the last revision or reapproval.

1. Scope

1.1 This practice provides a summary of equipment and procedures for ultrasonic testing of geomembranes using the pulse echo method.

1.2 Ultrasonic wave propagation in solid materials is correlated to physical and mechanical properties and condition of the materials. In ultrasonic testing, two wave propagation characteristics are commonly determined: velocity (based on wave travel time measurements) and attenuation (based on wave amplitude measurements). Velocity of wave propagation is used to determine thickness, density, and elastic properties of materials. Attenuation of waves in solid materials is used to determine microstructural properties of the materials. In addition, frequency characteristics of waves are analyzed to investigate the properties of a test material. Travel time, amplitude, and frequency distribution measurements are used to assess the condition of materials to identify damage and defects in solid materials. Ultrasonic measurements are used to determine the nature of materials/media in contact with a test specimen as well. Measurements are conducted in the time-domain (time versus amplitude) or frequency-domain (frequency versus amplitude).

1.3 Measurements of one or more ultrasonic wave transmission characteristics are made based on the requirements of the specific testing program.

1.4 The values stated in SI units are to be regarded as standard. No other units of measurement are included in this standard.

1.5 *This standard does not purport to address all of the safety concerns, if any, associated with its use. It is the responsibility of the user of this standard to establish appropriate safety, health, and environmental practices and determine the applicability of regulatory limitations prior to use.*

1.6 *This international standard was developed in accordance with internationally recognized principles on standardization established in the Decision on Principles for the Development of International Standards, Guides and Recommendations issued by the World Trade Organization Technical Barriers to Trade (TBT) Committee.*

2. Referenced Documents

2.1 *ASTM Standards:*²

[D4354 Practice for Sampling of Geosynthetics and Rolled Erosion Control Products \(RECPs\) for Testing](#)

[D4437 Practice for Nondestructive Testing \(NDT\) for Determining the Integrity of Seams Used in Joining Flexible Polymeric Sheet Geomembranes](#)

¹ This practice is under the jurisdiction of ASTM Committee D35 on Geosynthetics and is the direct responsibility of Subcommittee D35.10 on Geomembranes. Current edition approved Jan. 15, 2022/Dec. 1, 2022. Published January 2022/January 2023. Originally approved in 2003. Last previous edition approved in 2013/2022 as D7006 – 03 (2013) (2022). DOI: 10.1520/D7006-03R22-10.1520/D7006-22.

² For referenced ASTM standards, visit the ASTM website, www.astm.org, or contact ASTM Customer Service at service@astm.org. For *Annual Book of ASTM Standards* volume information, refer to the standard's Document Summary page on the ASTM website.

D4545 Practice for Determining the Integrity of Factory Seams Used in Joining Manufactured Flexible Sheet Geomembranes
(Withdrawn 2008)³

D4883 Test Method for Density of Polyethylene by the Ultrasound Technique

E1316 Terminology for Nondestructive Examinations

3. Terminology

3.1 Definitions:

3.1.1 *atmosphere for testing geomembranes, n*—air maintained at a relative humidity of 50 to 70 % and a temperature of 21 ± 1 °C.

3.1.2 *geomembrane, n*—an essentially impermeable geosynthetic composed of one or more synthetic sheets.

3.1.3 For definitions of terms related to ultrasonic testing, refer to Terminology **E1316**.

4. Summary of Practice

4.1 Mechanical waves are introduced to a geomembrane from a surface of the material using an ultrasonic transducer. Transmission characteristics of the waves in the geomembrane are determined. The measured characteristics are used to evaluate certain properties and ~~conditions~~condition of geomembranes.

5. Significance and Use

5.1 This practice covers test arrangements, measurement techniques, sampling methods, and calculations to be used for nondestructive evaluation of geomembranes using ultrasonic testing.

5.2 Wave velocity may be established for particular geomembranes (for specific polymer type, specific formulation, specific density). Relationships may be established between velocity and both density and tensile properties of geomembranes. An example of the use of ultrasound for determining density of polyethylene is presented in Test Method **D4883**. Velocity measurements may be used to determine thickness of geomembranes (**1, 2**).⁴ Travel time and amplitude of transmitted waves may be used to assess the condition of geomembranes and to identify defects in geomembranes including surface defects (for example, scratches, cuts), inner defects (for example, discontinuities within geomembranes), and defects that penetrate the entire thickness of geomembranes (for example, pinholes) (**3, 4**). Bonding between geomembrane sheets can be evaluated using travel time, velocity, or impedance measurements for seam assessment (**5-10**). Examples of the use of ultrasonic testing for determining the integrity of field and factory seams through travel time and velocity measurements (resulting in thickness measurements) are presented in Practices **D4437** and **D4545**, respectively. An ultrasonic testing device is routinely used for evaluating seams in prefabricated bituminous geomembranes in the field (**11**). Integrity of geomembranes may be monitored in time using ultrasonic measurements.

NOTE 1—Differences may exist between ultrasonic measurements and measurements made using other methods due to differences in test conditions such as pressure applied and probe dimensions. An example is ultrasonic and mechanical thickness measurements.

5.3 The method is applicable to testing both in the laboratory and in the field for parent material and seams. The test durations are very short as wave transmission through geomembranes occurs within microseconds.

6. Apparatus

6.1 The test equipment consists of a single transducer (both transmitter and receiver); a pulse generator; a pulse receiver (includes amplifier and filters for noise reduction); electronic circuits to measure and record waveforms, to measure wave travel time, to measure wave amplitudes, and to display received signals; electronic circuitry to time and synchronize all instrument functions; and connecting cables. The test apparatus is shown in **Fig. 1**.

6.2 Piezoelectric transducers are effective for wave transmission. Compressional waves (P-waves, longitudinal waves) shall be used for ultrasonic testing of geomembranes. A spacer shall be used to obtain good near surface resolution and to eliminate near field effects for accurate measurement of ultrasonic wave propagation characteristics in geomembranes. A plastic spacer has been

³ The last approved version of this historical standard is referenced on www.astm.org.

⁴ The boldface numbers in parentheses refer to the list of references at the end of this standard.

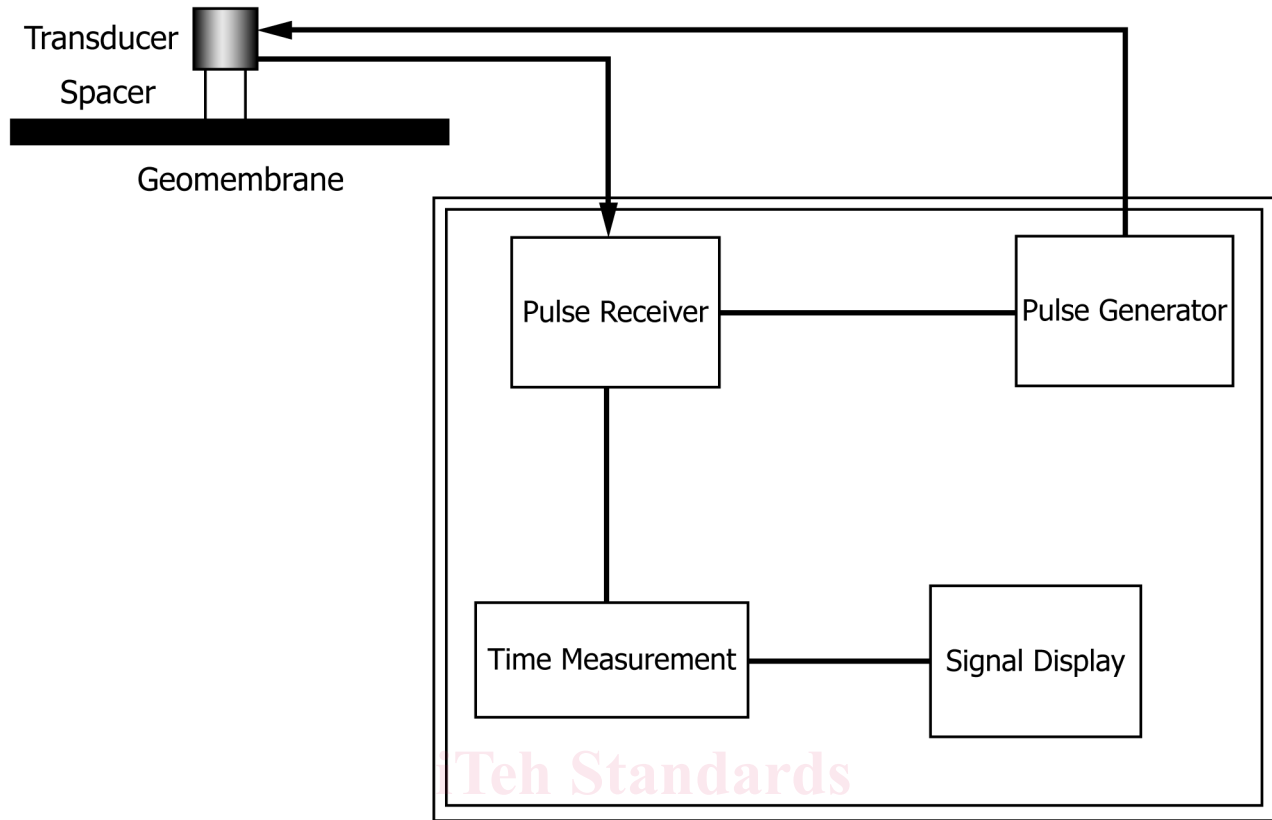

FIG. 1 Test Apparatus

found to be effective for geomembranes. The thickness of the spacer shall be at least twice the thickness of the test specimen. The thickness of the spacer shall be less than five to ten times the thickness of the test geomembrane. For testing geomembranes with various thicknesses, use the material with the largest thickness for selection of the thickness of the spacer. The spacer shall be sufficiently large to cover the active surface area of the transducer to ensure that the waveform generated is fully transmitted to the test specimen through the spacer. The center frequency of the transducer shall be between 1 and 20 MHz (a 10 MHz transducer has been found to be effective). Focused transducers shall be used for textured geomembranes to ensure measurements are made over essentially a “point” on the test material. Other means may also be used if high-frequency mechanical waves can be generated with these devices.

6.3 Pulse generator shall generate pulses of electrical energy that activate the transducer. Pulsers that generate spike or square wave type voltage pulses have been found to be effective for testing geomembranes.

6.4 The receiver shall amplify and filter the signal received by the transducer after the waves have been transmitted through a test sample-specimen.

6.5 Electronic circuitry shall be used to measure travel time of waves in a test sample-specimen. The circuitry shall allow for determination of travel times with a precision equal to or better than 0.1 μ s. If attenuation and amplitude measurements are desired, instrumentation shall be used to record the waveforms received from a test material. The circuitry shall allow for determination of amplitudes with a precision equal to or better than 1 mV. Electronic circuitry may also be used to display received signals. Analog to digital converters and computerized signal acquisition and analysis setups have been found to be effective for testing geomembranes.

6.6 Electronic circuitry shall be used to time and synchronize all instrument functions to eliminate uncertainty in the determination of wave transit times.

NOTE 2—The apparatus listed here has been found to be effective for testing geomembranes. Ultrasonic testing of materials is a well-established field and other types of devices may also be used for testing geomembranes. Details for various test arrangements and examples of devices produced by various manufacturers are available in (12). Effectiveness of alternative devices shall be demonstrated prior to their routine use for geomembranes.

7. Materials

7.1 A coupling agent shall be used to ensure good contact between the transducer and test specimen. Coupling agents include water, commercial ultrasonic couplants, oil, petroleum jelly, grease, glycerin, propylene glycol, or other viscous fluids. Water has been used effectively on flat surfaces. More viscous materials may be used on inclined surfaces.

8. Sampling and Test Specimens

8.1 Use Practice [D4354](#) for sampling geomembranes.

8.2 Test specimens shall be cut such that a distance greater than ten times the thickness of the specimen shall be left between the transducer and the edges of the specimen in every direction.

8.3 In field testing, measurements shall be taken at locations that are at a distance greater than ten times the thickness of the specimen from the edges of the geomembrane sheet in any direction.

NOTE 3—Seam inspection tests may be conducted at locations closer to the edge of geomembranes than specified in [8-28.3](#). Effectiveness of the near edge measurements shall be demonstrated prior to their routine use to ensure that potential edge reflections do not interfere with measurements through the thickness of geomembranes.

9. Calibration

9.1 The electronic equipment shall be calibrated to ensure accurate determination of the transit time. Calibration bars or blocks with known thicknesses and wave transmission velocities shall be used for calibration procedures.

10. Conditioning

10.1 For baseline measurements (for example, measurements used to establish baseline ultrasonic properties for a particular geomembrane), specimens shall be exposed to the standard atmosphere for testing geomembranes for a period sufficient to reach moisture and temperature equilibrium. Exposure for 24 h has been found to be effective for reaching equilibrium.

10.2 Tests can be conducted at conditions outside the range for standard atmosphere conditions for various applications such as field measurements. For these measurements, specimens shall be in moisture and temperature equilibrium with their surrounding environment. Correction factors shall be used if comparisons are to be made between standard and nonstandard testing conditions. Correction factors are determined by taking measurements at nonstandard conditions and normalizing these by the measurements conducted at standard conditions.

NOTE 4—~~Correction factors shall be used if comparisons are to be made between standard and nonstandard testing conditions. Correction factors are determined by taking measurements at nonstandard conditions and normalizing these by the measurements conducted at standard conditions.~~

10.3 *Surface Preparation*—The surface of the test geomembrane shall be free of excessive dust, particles, and any other materials that may interfere with wave transmission. The surface of geomembranes may be cleaned with a damp cloth to ensure a clean measurement surface prior to testing.

11. Procedure

11.1 Ultrasonic measurements in geomembranes shall be conducted using the pulse echo test method. In this method, ultrasonic waves are sent and received from one surface of a test specimen using one or two transducers. A single transducer shall be used in the measurements of geomembranes.

11.2 Ultrasonic measurements on geomembranes may be taken using two test arrangements. In both arrangements, the transducer shall be orthogonal to the test geomembrane.

11.2.1 *Arrangement A*—In this arrangement the transducer assembly is placed over the test geomembrane. The transducer assembly consists of the ultrasonic transducer and the spacer. Apply a small amount of couplant between the transducer and the spacer to ensure that the two units are in good contact with no air gaps. Then, apply a small amount of couplant on the surface of the geomembrane at the measurement location. Place the transducer assembly on the geomembrane, leaving a thin film of

couplant between the assembly and the geomembrane. Ensure that the transducer assembly is in good contact (for example, no air gaps) with the geomembrane. A small load may be permanently attached on top of the transducer to provide good contact with the geomembrane and ensure that the transducer is perfectly orthogonal to the test specimen. This arrangement is presented in Fig. 2(a).

11.2.2 *Arrangement B*—In this arrangement the transducer assembly is placed below the test geomembrane. Apply a small amount of couplant between the transducer and the spacer to ensure that the two units are in good contact with no air gaps. Then, apply a small amount of couplant on the top surface of the spacer. Place the geomembrane over the spacer, leaving a thin film of couplant between the spacer and the geomembrane. Ensure that the geomembrane is in good contact (for example, no air gaps) with the transducer assembly. This arrangement is presented in Fig. 2(b). In this arrangement, no pressure is applied to the geomembrane. Pressure can affect the thickness of the geomembrane, which can affect the travel time in the geomembrane. This arrangement is applicable when the underside of a geomembrane is accessible.

NOTE 4—Commercially available “delay line” transducers can be used in Test Arrangement A. These transducers have plastic spacers attached to the

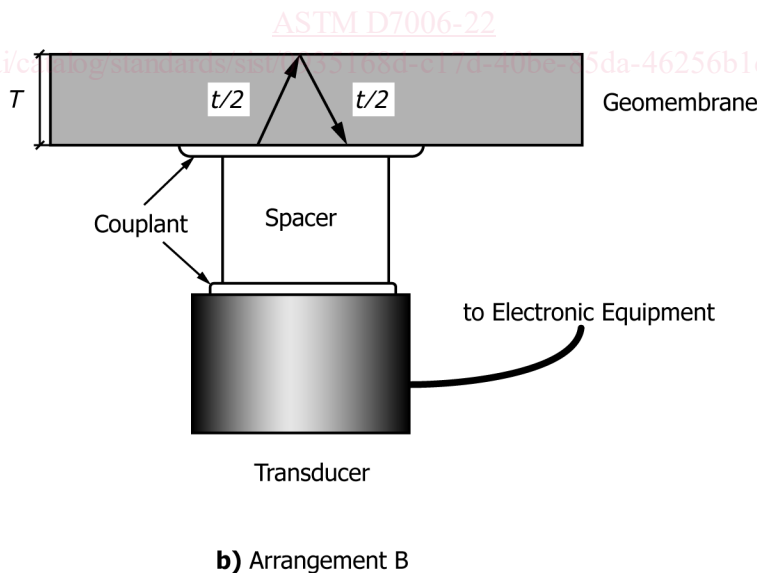
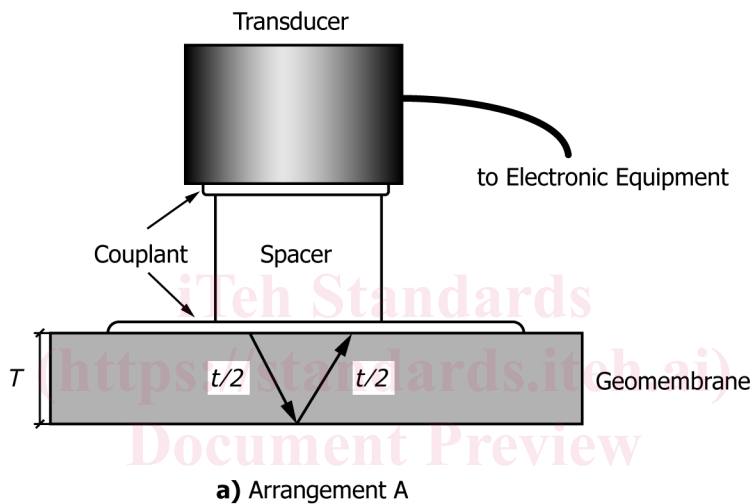

→ P-wave transmitted in a geomembrane

T = thickness of geomembrane

t = total travel time in geomembrane

FIG. 2 Test Arrangements

ultrasonic units. Use of these types of transducers has been found to be effective for testing geomembranes. Commercially available immersion transducer setups can be used in Test Arrangement B. In these setups a water-resistant transducer is placed at a certain depth in a water bath. The specimen is placed directly on the surface of water at a fixed distance away from the transducer. The water between the specimen and the transducer acts as the spacer. These systems are particularly effective for focused transducers. Care must be taken not to leave the test specimen in contact with water for extended periods of time when using these setups. Test specimens shall not be exposed to water for more than 30 min during a test.

11.2.3 If comparisons will be made between ultrasonic measurements, similar test arrangements shall be used. In particular, the pressure applied to a geomembrane during the ultrasonic tests shall be the same for comparative analyses.

11.2.4 The gain and frequency response characteristics of the receiver shall be kept constant within a test program and between test programs if comparisons will be made.

11.3 Subsequent to proper placement of the specimen and the transducer assembly, take a measurement by sending and receiving pulses in the geomembrane. Record the travel time directly or record the received signal for further processing to determine the travel time and/or amplitude of the waves. Take the average of at least ten measurements (waveforms) for determination of ultrasonic properties. Averaging reduces the noise in the measured waveforms and allows for obtaining good quality measurements. An example of a waveform obtained on an intact geomembrane is presented in Fig. 3. An example of a waveform obtained on the same type of geomembrane with a defect on the underside (not visible from the top surface) is presented in Fig. 4.

NOTE 5—Various electronic devices allow for automatic recording of multiple transit times or signals and are equipped with circuitry to display individual or average results.

11.4 Move the transducer assembly (Test Arrangement A) or the specimen (Test Arrangement B) to the next measurement location and repeat 11.1 – 11.3. Wipe off extra couplant from the surface of the test specimens.

12. Calculation

12.1 Calculations can be made to determine ultrasonic wave velocity and attenuation characteristics of geomembranes. These parameters can be used directly to determine properties of geomembranes (for example, thickness) or correlated to pre-established relationships to determine properties of geomembranes (for example, tensile properties). The amplitude response of test specimens can be quantified to determine the condition of geomembranes. Measurements can be made using time- or frequency-domain data. The user shall be responsible for selecting the data analyses approaches for the intended use of the ultrasonic testing program.

12.2 Wave velocity is calculated using travel time and specimen thickness.

12.2.1 Determine the travel time of waveforms using a time-domain plot. Measure the travel time with a precision at least equal to 0.1 μ s. Travel time may be determined on a time-domain record of waveforms using the time difference between the peaks of the reflections from the top and the bottom surface of a geomembrane (Fig. 3). Alternatively, the travel time may be determined using the locations where the reflections deviate significantly from the baseline values. Various electronic devices, in particular small, handheld devices, are set up to provide travel time measurements automatically without a record of waveforms. The user shall understand the method of travel time determination in automated setups. The same approach shall be used to determine wave travel times within a test program and between test programs if comparisons will be made. The thickness of the specimen (predetermined most likely using mechanical means) shall be available with a precision at least equal to 0.01 mm. Pressure applied to the specimens for mechanical thickness measurements shall be similar to the pressure applied to the specimens in ultrasonic tests.

12.2.2 Calculate the wave velocity as follows:

$$V = (T)/(t/2) \quad (1)$$

where:

V = wave velocity, m/s,
 T = thickness of geomembrane, m, and
 t = total travel time, s.

12.3 Attenuation is determined using the amplitude of successive reflections obtained from a time-domain plot (for example, Fig. 5). Determine attenuation as follows:

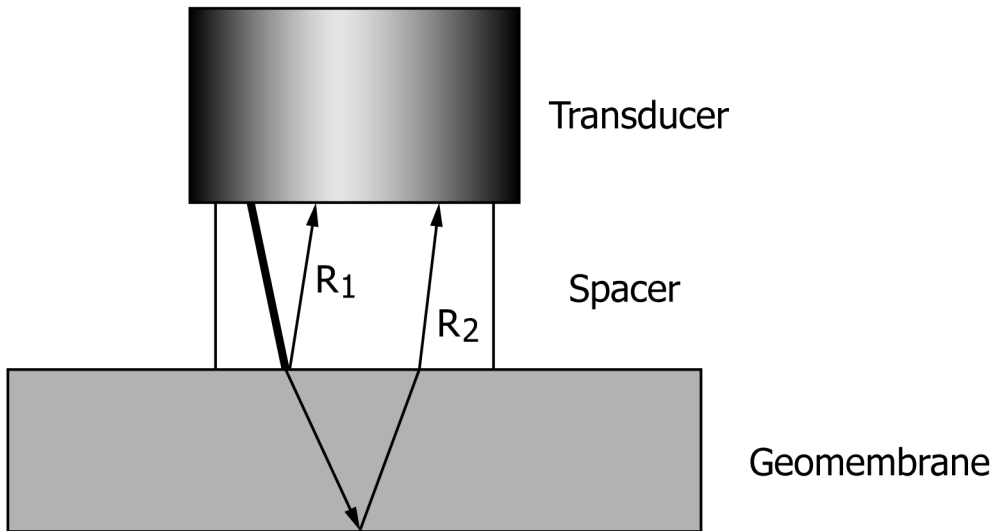

- Incident Wave
- Wave Transmitted to the Geomembrane
(Reflected from the bottom surface of the geomembrane)

Note: Waves are actually normal to the interfaces, but are illustrated at an angle for clarity.

(<https://standards.iteh.ai>)
Document Preview

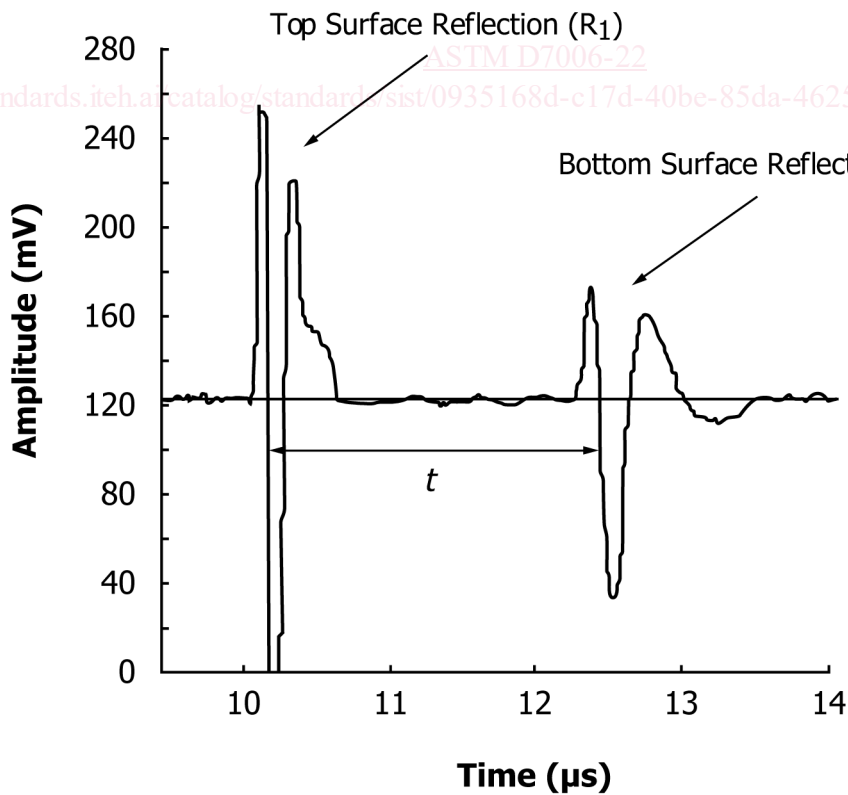

FIG. 3 Typical Waveforms for an Intact Geomembrane