



Designation: D2919 – 01 (Reapproved 2023)

Standard Test Method for Determining Durability of Adhesive Joints Stressed in Shear by Tension Loading¹

This standard is issued under the fixed designation D2919; the number immediately following the designation indicates the year of original adoption or, in the case of revision, the year of last revision. A number in parentheses indicates the year of last reapproval. A superscript epsilon (ϵ) indicates an editorial change since the last revision or reapproval.

This standard has been approved for use by agencies of the U.S. Department of Defense.

1. Scope

1.1 This test method covers data for assessing the durability of adhesive lap-shear joints while stressed in contact with air, air in equilibrium with certain solutions, water, aqueous solutions, or other environments at various temperatures.

1.2 *This standard does not purport to address all of the safety concerns, if any, associated with its use. It is the responsibility of the user of this standard to establish appropriate safety, health, and environmental practices and determine the applicability of regulatory limitations prior to use.* Specific precautionary statements are given in 7.4.

1.3 The values stated in SI units are considered to be the standard. The values in parentheses are for information only.

1.4 *This international standard was developed in accordance with internationally recognized principles on standardization established in the Decision on Principles for the Development of International Standards, Guides and Recommendations issued by the World Trade Organization Technical Barriers to Trade (TBT) Committee.*

2. Referenced Documents

2.1 *ASTM Standards:*²

[D907 Terminology of Adhesives](#)

[D1002 Test Method for Apparent Shear Strength of Single-Lap-Joint Adhesively Bonded Metal Specimens by Tension Loading \(Metal-to-Metal\)](#)

[D1828 Practice for Atmospheric Exposure of Adhesive-Bonded Joints and Structures](#)

[D2294 Test Method for Creep Properties of Adhesives in Shear by Tension Loading \(Metal-to-Metal\)](#)

[D3165 Test Method for Strength Properties of Adhesives in Shear by Tension Loading of Single-Lap-Joint Laminated Assemblies](#)

[E4 Practices for Force Calibration and Verification of Testing Machines](#)

2.2 *ASTM Adjuncts:*

[Durability Test Apparatus Drawings](#)³

3. Terminology

3.1 *Definitions*—Definitions of terms in this test method may be found in Terminology [D907](#).

4. Significance and Use

4.1 The combination of stress and moisture decreases the durability of most adhesive joints. Stresses in the presence of water or water vapor may cause some adhesive joints to fail at some small fraction of the stress required to break the dry joint. The time to failure for a given adhesive joint generally decreases with increasing stress, temperature, and relative humidity.

4.2 This test method may be used as an accelerated screening test for assessing the durability of adhesive joints. It may be used to measure durability of adhesive joints exposed outdoors or to environmental conditions experienced by adhesive joints in service. The tests may also be used to determine the effects of various surface preparations or substrates on durabilities of adhesive joints.

4.3 The durability performance of various adhesives may be compared by using this test method under uniform sets of conditions. To assess the overall durability of a given adhesive, lap-shear joints should be tested under a range of stress, relative humidity, and temperature. For a specific end use it may be possible to obtain the needed durability data using only one set of test conditions.

¹ This test method is under the jurisdiction of ASTM Committee [D14](#) on Adhesives and is the direct responsibility of Subcommittee [D14.80](#) on Metal Bonding Adhesives.

Current edition approved Jan. 1, 2023. Published January 2023. Originally approved in 1971. Last previous edition approved in 2014 as D2919 – 01 (2014). DOI: 10.1520/D2919-01R23.

² For referenced ASTM standards, visit the ASTM website, www.astm.org, or contact ASTM Customer Service at service@astm.org. For *Annual Book of ASTM Standards* volume information, refer to the standard's Document Summary page on the ASTM website.

³ Detailed working drawings for the construction of the durability test apparatus are available from ASTM International Headquarters. Order Adjunct No. [ADJD2919](#). Original adjunct produced in 1980.

5. Apparatus

5.1 *Fixture*, as shown in Fig. 1,³ is required for this test method, although a fixture such as described in Test Method D2294 may also be suitable for the performance of this test.

5.2 *Testing Machine*, or other suitable machine capable of applying measured compressive loads. Force measurements have an accuracy of $\pm 1\%$ of any reading when calibrated in compliance with Practices E4 requirements. Machine that is equipped with a suitable loading base as shown in Fig. 1, shall be used as a loading mechanism.

5.3 *Outdoor Weathering Racks (Standard)* are recommended (Practice D1828), but any stable frame may be used (for example, galvanized pipe or painted steel channel). No other special apparatus is required for outdoor tests.

6. Test Specimens

6.1 The successful use of this test method depends on preparing good quality lap-shear joints. The test joints must be prepared carefully in accordance with the adhesive manufacturer's directions or in accordance with some other specified

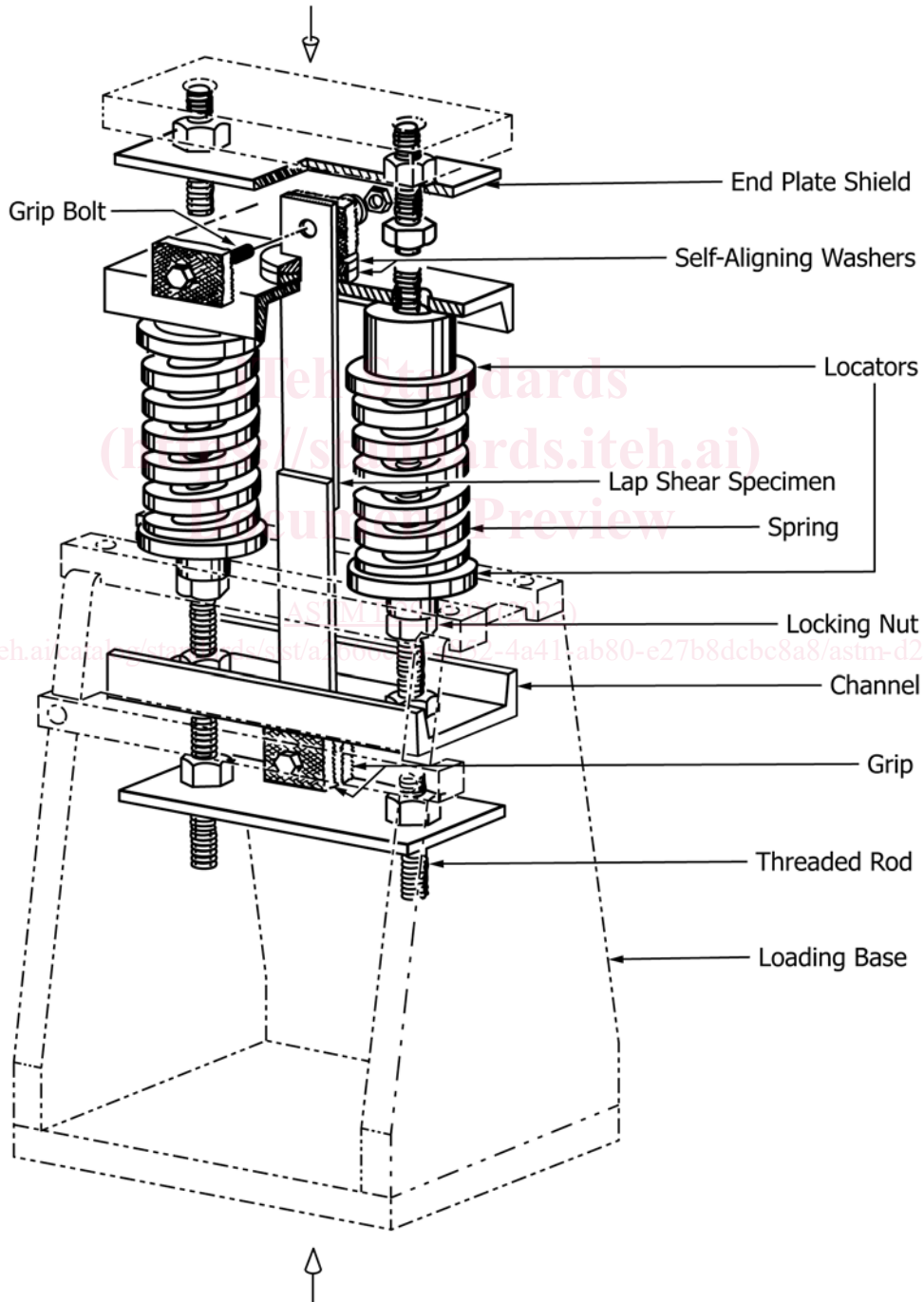

FIG. 1 Durability Test Apparatus

set of conditions agreed upon between the manufacturer and the purchaser. It is recommended that the test joints be prepared in accordance with Test Method D1002, except that the dimensions of the test specimens shall be as shown in Fig. 2.

6.2 If the fixture in Fig. 1 is used, test specimens of the dimensions shown in Fig. 2 must be used. If the fixture described in Test Method D2294 is used, the test specimen described in that test method must be used.

6.3 If it is desired to use test specimens of thickness or overlap different from that recommended in this test method or in Test Method D2294, the guidelines set forth in Note 2 and Note 3 of Test Method D1002, regarding permissible test specimen dimensions with respect to thickness and overlap, shall be followed. Test specimen size, of course, must always be compatible with the appropriate fixture.

6.4 An alternative test specimen may be used in accordance with Test Method D3165 with the exception that the lengthwise dimension must be compatible with the test specimen shown in Fig. 2.

7. Procedure

7.1 Test six specimens to destruction at 23.0 °C ± 1 °C (73.4 °F ± 1.8 °F) and 50 % ± 2 % relative humidity in accordance with Test Method D1002, after conditioning in this environment for not less than 40 h, unless otherwise specified. Compute and record the maximum, minimum, and average value of the failing stress.

7.2 Place a minimum of six test specimens for each test environment in test fixtures. To load each assembled test fixture, after being certain that the safety end plate shields are firmly in place, place the fixture, supported by the loading base, in the loading machine and apply approximately 1 % of the desired stress to the springs. Tighten the grip bolts to 0.45 N·m to 0.56 N·m (40 lbf·in. to 50 lbf·in.) torque, then apply the remainder of the stress. Turn the locking nuts directly under the lower spring locators until they are finger tight. Release the load applied by the machine and remove the loaded fixture (see 7.4). Do not exceed the average initial failing stress determined above.

7.3 Expose the stressed test specimens to one of the standard test environments specified in Table 1. Expose the test

TABLE 1 Standard Test Environments

Test Environment Number	Temperature ^A	Moisture Conditions ^B
1	23 °C (73.4 °F)	immersed in distilled or de-ionized water
2	23 °C (73.4 °F)	50 % RH (relative humidity)
3	23 °C (73.4 °F)	15 % RH
4	35 °C (95 °F)	90 % RH
5	35 °C (95 °F)	100 % RH
6	50 °C (122 °F)	90 % RH
7	50 °C (122 °F)	100 % RH
8	35 °C (95 °F)	5 % salt fog
9	ambient (outdoors)	ambient (outdoors)
10	other (specify)	other, including aqueous solutions or nonaqueous liquids (specify)

^A The tolerance for test temperature shall be ±1 °C or 1.8 °F for environments 1 to 8.

^B The moisture condition may be provided by controlling the relative humidity of a box, room, or other chamber by any convenient means.

specimens to the environment in an attitude such that the condensate of the environment drains properly. Therefore expose the test specimens with the edges horizontal and with the test specimen width perpendicular to the horizontal plane. Make periodic observations of their condition and record the length of time to failure for each test specimen and the average for the six test specimens (or more) to the test environment.

7.4 Exercise extreme caution to ensure that loading of the fixture and handling of a loaded fixture be carried out in a safe manner, particularly that parts of the body be maintained at a safe distance from the test specimen in case it should accidentally break during these operations.

8. Report

8.1 Report the following information:

8.1.1 Complete identification of the adhesive tested, including type, source, date manufactured, manufacturer’s code numbers, form, etc.

8.1.2 Complete identification of the adherends used, including composition, thickness, and temper for metals.

8.1.3 Surface preparation, application, and bonding conditions used in preparing the test specimens.

8.1.4 Length of overlap used and bondline thickness.

8.1.5 Maximum, minimum, and average failing stress of the joints tested in accordance with Section 7.

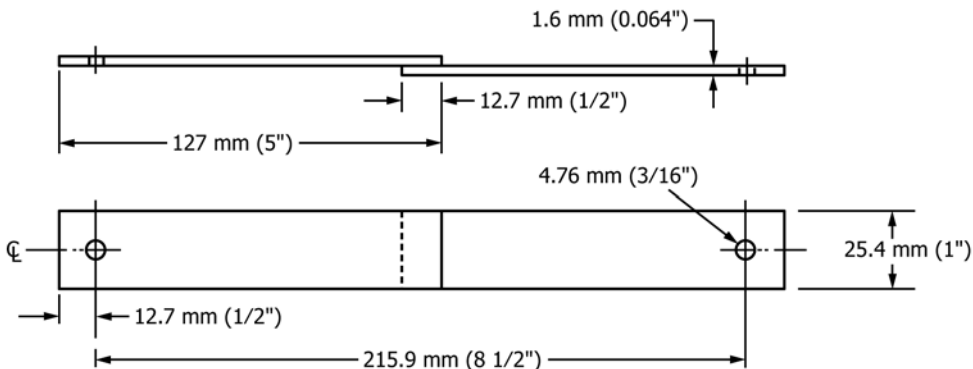

FIG. 2 Form and Dimensions of Test Specimen