



Designation: D3165 – 07 (Reapproved 2023)

Standard Test Method for Strength Properties of Adhesives in Shear by Tension Loading of Single-Lap-Joint Laminated Assemblies¹

This standard is issued under the fixed designation D3165; the number immediately following the designation indicates the year of original adoption or, in the case of revision, the year of last revision. A number in parentheses indicates the year of last reapproval. A superscript epsilon (ϵ) indicates an editorial change since the last revision or reapproval.

1. Scope

1.1 This test method (**Note 1**) is intended for determining the comparative shear strengths of adhesives in large area joints when tested on a standard single-lap-joint specimen and under specified conditions of preparation and testing. Adhesives respond differently in small versus large area joints (**Note 2**).

NOTE 1—While this test method is intended for use in metal-to-metal applications, it may be used for measuring the shear properties of adhesives using plastic adherends, provided consideration is given to the thickness and rigidity of the plastic adherends. Doublers or bonded tabs may be required for plastic adherends to prevent bearing failure in the adherends.

NOTE 2—This variation can be influenced by adhesive density, flow characteristics, cure rate, gel time, carrier composition, entrapped volatiles, volatiles released during cure, etc. and also by cure cycle variables including: temperature, time, pressure, rise rate to temperature, cool-down rate, etc. In addition to the processing variables joint size changes the level of constraint on the adhesive as well as the influence of induced tensile loads at the edge of the joint during mechanical or thermal loading.

1.2 The values stated in SI units are to be regarded as the standard. The values given in parentheses are for information only.

1.3 *This standard does not purport to address all of the safety concerns, if any, associated with its use. It is the responsibility of the user of this standard to establish appropriate safety, health, and environmental practices and determine the applicability of regulatory limitations prior to use.*

1.4 *This international standard was developed in accordance with internationally recognized principles on standardization established in the Decision on Principles for the Development of International Standards, Guides and Recommendations issued by the World Trade Organization Technical Barriers to Trade (TBT) Committee.*

¹ This test method is under the jurisdiction of ASTM Committee D14 on Adhesives and is the direct responsibility of Subcommittee D14.80 on Metal Bonding Adhesives.

Current edition approved Jan. 1, 2023. Published January 2023. Originally approved in 1973. Last previous edition approved in 2014 as D3165 – 07 (2014). DOI: 10.1520/D3165-07R23.

2. Referenced Documents

2.1 ASTM Standards:²

- A167 Specification for Stainless and Heat-Resisting Chromium-Nickel Steel Plate, Sheet, and Strip (Withdrawn 2014)³
- A366/A366M Specification for Commercial Steel (CS) Sheet, Carbon, (0.15 Maximum Percent) Cold-Rolled (Withdrawn 2000)³
- B36/B36M Specification for Brass Plate, Sheet, Strip, and Rolled Bar
- B152/B152M Specification for Copper Sheet, Strip, Plate, and Rolled Bar
- B209 Specification for Aluminum and Aluminum-Alloy Sheet and Plate (Metric) B0209_B0209M
- B265 Specification for Titanium and Titanium Alloy Strip, Sheet, and Plate
- D907 Terminology of Adhesives
- D2093 Practice for Preparation of Surfaces of Plastics Prior to Adhesive Bonding
- D2651 Guide for Preparation of Metal Surfaces for Adhesive Bonding
- D3933 Guide for Preparation of Aluminum Surfaces for Structural Adhesives Bonding (Phosphoric Acid Anodizing)
- D4896 Guide for Use of Adhesive-Bonded Single Lap-Joint Specimen Test Results
- E4 Practices for Force Calibration and Verification of Testing Machines

3. Terminology

3.1 **Definitions**—Many terms in this test method are defined in Terminology D907.

4. Significance and Use

4.1 This test method is useful in that the joint configuration closely simulates the actual joint configuration of many bonded

² For referenced ASTM standards, visit the ASTM website, www.astm.org, or contact ASTM Customer Service at service@astm.org. For *Annual Book of ASTM Standards* volume information, refer to the standard's Document Summary page on the ASTM website.

³ The last approved version of this historical standard is referenced on www.astm.org.

assemblies. Surface preparation of the adherends can affect the apparent shear strength of the adhesive and can be one of the variables under study.

4.2 This test method is also useful as an in-process quality control test for laminated assemblies. In practice the laminated assembly is either made over size and test specimens removed from it or a percentage of the assemblies are destructively tested.

4.3 The misuse of strength values obtained from this test method as design allowable stress values for structural joints could lead to product failure, property damage, and human injury. The apparent shear strength of an adhesive obtained from a given small single-lap specimen may differ from that obtained from a joint made with different adherends or by a different bonding process. The normal variation of temperature and moisture in the service environment causes the adherends and the adhesive to swell and shrink. The adherends and adhesive are likely to have different thermal and moisture coefficients of expansion.

4.3.1 Even in small specimens, short-term environmental changes can induce internal stresses or chemical changes in the adhesive that permanently affect the apparent strength and other mechanical properties of the adhesive. The problem of predicting joint behavior in a changing environment is even more difficult if a different type of adherend is used in a larger structural joint than was used in the small specimen.

4.4 The apparent shear strength measured with a single-lap specimen is not suitable for determining design allowable stresses for designing structural joints that differ in any manner from the joints tested without thorough analysis and understanding of the joint and adhesive behaviors.

4.5 Single-lap tests may be used for comparing and selecting adhesives or bonding processes for susceptibility to fatigue and environmental changes, but such comparisons must be made with great caution since different adhesives may respond differently in different joints. Review Guide D4896 for further discussion of concepts for interpretation of adhesive-bonded single-lap joint data.

5. Apparatus

5.1 *Testing Machine*, conforming to the requirements of Practice E4. The testing machine shall be so selected that the breaking load of the specimens falls between 15 and 85 % of the full-scale capacity. The machine shall be capable of maintaining a rate of loading of 8.3 MPa/min to 9.7 MPa/min (1200 psi/min to 1400 psi/min), or, if the rate is dependent on crosshead motion, the machine should be set to approach this rate of loading [approximately 1.27 mm/min (0.05 in./min) crosshead speed]. It shall be provided with a suitable pair of self-aligning grips to hold the specimen. It is recommended that the jaws of these grips shall engage the outer 25.4 mm (1 in.) of each end of the test specimen firmly (Note 3). The grips and attachments shall be so constructed that they will move into alignment with the test specimen as soon as the load is applied, so that the long axis of the test specimen will coincide with the direction of the applied pull through the center of the grip assembly.

NOTE 3—The length of overlap in the specimen may be varied where necessary. The length of the specimen between the end of the jaws to the beginning of the lap however, must not be varied. This distance should be 63 mm (2.5 in.) in all tests.

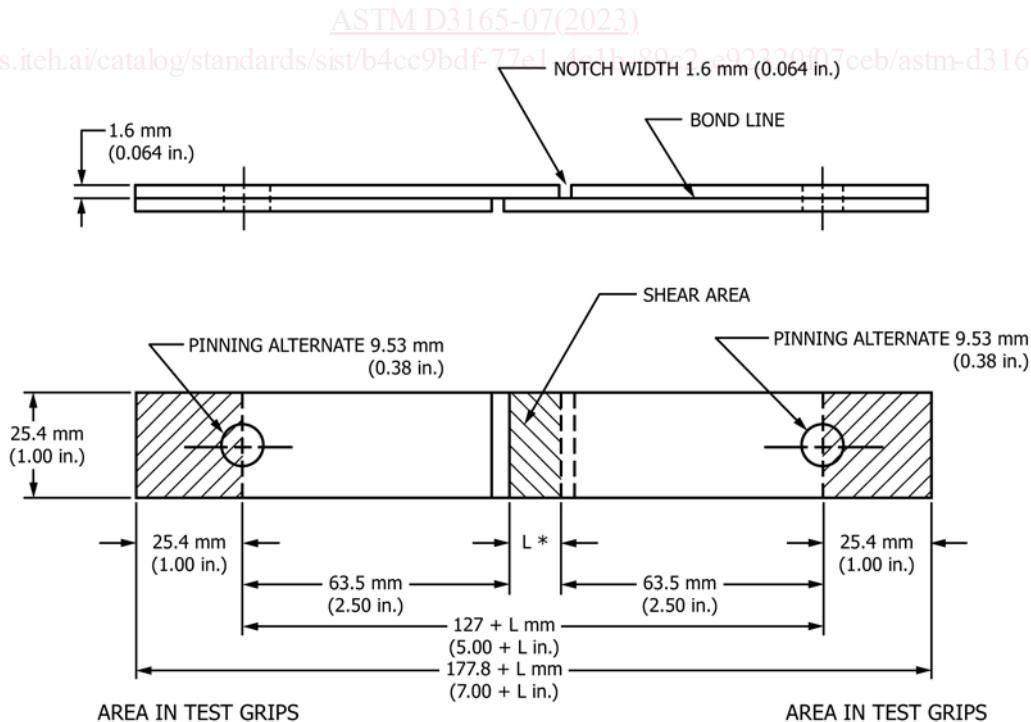

NOTE 1—*L = length of test area. Length of test area can be varied. Recommended length of lap is 12.7 mm ± 0.3 mm (0.50 in. ± 0.01 in.).

FIG. 1 Form and Dimensions of Test Specimen

6. Test Specimens

6.1 Test specimens shall conform to the form and dimensions shown in Fig. 1. These shall be cut from test joints Fig. 2, prepared as prescribed in Sections 7 and 8. The recommended thickness of most metal sheets is 1.62 mm ± 0.125 mm (0.064 in. ± 0.005 in.) (Note 4). The recommended length of overlap for most metals of 1.62 mm (0.064 in.) thickness is 12.7 mm ± 0.3 mm (0.50 in. ± 0.01 in.) (Note 5).

NOTE 4—Since it is undesirable to exceed the yield point of the metal in tension during test, the permissible length of overlap in the specimen will vary with the thickness and type of metal, and on the general level of strength of the adhesive being investigated. The maximum permissible length may be computed from the following relationship:

$$L = F_{ty} T / \tau \tag{1}$$

where:

L = length of overlap, in.,

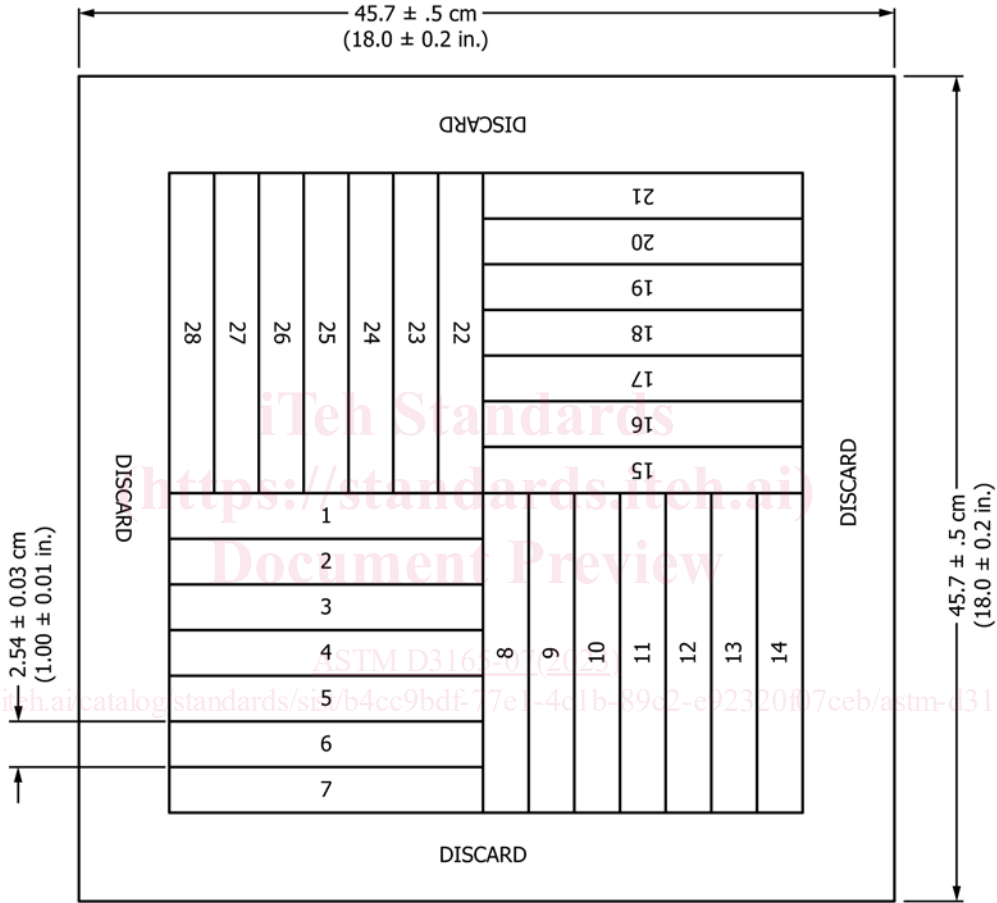

NOTE 1—(All discards to be of common width as determined by width of cutting tool.)

FIG. 2 Standard Test Joint