



Designation: C1812/C1812M – 22

# Standard Practice for Design of Journal Bearing Supports to be Used in Fiber Reinforced Concrete Beam Tests<sup>1</sup>

This standard is issued under the fixed designation C1812/C1812M; the number immediately following the designation indicates the year of original adoption or, in the case of revision, the year of last revision. A number in parentheses indicates the year of last reapproval. A superscript epsilon ( $\epsilon$ ) indicates an editorial change since the last revision or reapproval.

## 1. Scope\*

1.1 This practice prescribes the design of journal-bearing type rollers to support each end of fiber-reinforced concrete beams tested using Test Method C1399/C1399M or Test Method C1609/C1609M. The roller design is intended to provide a consistent and relatively low value of effective coefficient of friction at the beam supports. The bearing design incorporates metal-on-metal sliding surfaces lubricated with grease.

NOTE 1—During the progress of a test, a crack or cracks open on the underside of the beam between the loaded third points causing the underside of each portion of the beam to move away from the center. The design is intended to provide for unlimited rotation of the roller at the point of contact with the test beam in response to this motion.

NOTE 2—The design of the supporting rollers is a significant factor in determining the magnitude of the arching forces that cause error in flexural test results.<sup>2</sup> Improperly designed supporting rollers can influence the apparent flexural behavior of fiber-reinforced concrete beams.<sup>3</sup> The effective coefficient of friction can be determined using a method similar to that described by Bernard.<sup>4</sup>

1.2 The text of this standard refers to notes and footnotes that provide explanatory material. These notes and footnotes (excluding those in tables and figures) shall not be considered as requirements of the standard.

1.3 *Units*—The values stated in either SI units or inch-pound units are to be regarded separately as standard. The values stated in each system are not necessarily exact equivalents; therefore, to ensure conformance with the standard, each

system shall be used independently of the other, and values from the two systems shall not be combined.

1.4 *This standard does not purport to address all of the safety concerns, if any, associated with its use. It is the responsibility of the user of this standard to establish appropriate safety, health, and environmental practices and determine the applicability of regulatory limitations prior to use.*

1.5 *This international standard was developed in accordance with internationally recognized principles on standardization established in the Decision on Principles for the Development of International Standards, Guides and Recommendations issued by the World Trade Organization Technical Barriers to Trade (TBT) Committee.*

## 2. Referenced Documents

2.1 *ASTM Standards:*<sup>5</sup>

C125 Terminology Relating to Concrete and Concrete Aggregates

C1399/C1399M Test Method for Obtaining Average Residual-Strength of Fiber-Reinforced Concrete

C1609/C1609M Test Method for Flexural Performance of Fiber-Reinforced Concrete (Using Beam With Third-Point Loading)

D4950 Classification and Specification for Automotive Service Greases

2.2 *SAE International Standard:*<sup>6</sup>

J 404 Chemical Composition of SAE Alloy Steels

## 3. Terminology

3.1 *Definitions:*

3.1.1 For definitions of terms used in this practice, refer to Terminology C125.

3.2 *Definitions of Terms Specific to This Standard:*

3.2.1 *effective coefficient of friction,  $n$* —a dimensionless ratio of the horizontal force required to initiate rotation of the

<sup>1</sup> This practice is under the jurisdiction of ASTM Committee C09 on Concrete and Concrete Aggregates and is the direct responsibility of Subcommittee C09.42 on Fiber-Reinforced Concrete.

Current edition approved Dec. 15, 2022. Published January 2023. Originally approved in 2015. Last previous edition approved in 2015 as C1812/C1812M–15. DOI: 10.1520/C1812\_C1812M-22.

<sup>2</sup> Zollo, R. F., 2013. "Analysis of Support Apparatus for Flexural Load-deflection Testing: Minimizing Bias," *Journal of Testing and Evaluation*, ASTM International, Vol. 41, No. 1, pp. 1-6.

<sup>3</sup> Wille, K. and Parra-Montesinos, G.J., 2012. "Effect of Beam Size, Casting Method, and Support Conditions on Flexural Behavior of Ultra-High-Performance Fiber-Reinforced Concrete," *ACI Journal of Materials*, Vol. 109, No. 3, pp. 379-388.

<sup>4</sup> Bernard, E.S., 2014. "Influence of friction in supporting rollers on the apparent flexural performance of third-point loaded fibre reinforced concrete beams," *Advanced Civil Engineering Materials*, ASTM International Vol. 2, No. 1, pp. 158-176.

<sup>5</sup> For referenced ASTM standards, visit the ASTM website, [www.astm.org](http://www.astm.org), or contact ASTM Customer Service at [service@astm.org](mailto:service@astm.org). For *Annual Book of ASTM Standards* volume information, refer to the standard's Document Summary page on the ASTM website.

<sup>6</sup> Available from SAE International (SAE), 400 Commonwealth Dr., Warrendale, PA 15096, <http://aerospace.sae.org>.

\*A Summary of Changes section appears at the end of this standard

roller support applied at the contact point between the roller and test beam divided by the normal force applied at the same point (see Fig. 1).

3.2.2 *roller, n*—a journal bearing capable of continuous rotation without exhibiting a significant variation in resistance to rotation.

#### 4. Significance and Use

4.1 The presence of friction in the supporting rollers used when testing a fiber-reinforced concrete beam will increase the apparent load resistance of the beam. Roller supports designed in accordance with this practice will provide a relatively low and consistent value of friction at the supports.

4.2 Two types of rollers are used to support a beam. One includes a cylindrical bearing that allows the roller assembly to rotate along an axis parallel to the longitudinal axis of the beam and thereby accommodate any warping introduced during specimen fabrication. The other roller does not include the cylindrical bearing.

4.3 The rollers are designed for use with 150 mm [6 in.] or 100 mm [4 in.] deep beams of square cross-section.

4.4 A method is provided for correcting the apparent load resistance measured using the roller with a known value of the effective coefficient of friction of the roller supports to obtain an estimate of the load resistance in the absence of friction.

#### 5. Apparatus

5.1 *Geometry*—A pair of rollers is required to support a beam during a test. The barrel of each roller, which is that portion of the roller in contact with the beam, shall be free to rotate about an axis perpendicular to the longitudinal axis of the beam to accommodate movement of the initial support point on the beam away from the center during a test. Friction

between sliding surfaces within each roller will generate a small resistance to rotation of the barrel relative to the mounting (see Fig. 1). A roller fabricated in accordance with this practice will exhibit an effective coefficient of friction of about 0.10.<sup>4</sup> Journal bearing supports manufactured in conformance with this practice do not need to be tested to confirm that the effective coefficient of friction meets requirements.

5.1.1 One of the two rollers supporting the underside of the beam shall be able to rotate about an axis parallel to the longitudinal axis of the beam to accommodate a warped test beam surface that could induce torsion in the beam during testing (see Note 3 and Fig. 2). The other roller shall be fixed against rotation about a longitudinal axis to prevent the beam from overturning during installation and testing (see Fig. 3). Rotation about a longitudinal axis shall be accommodated by inclusion of a cylindrical bearing surface under the roller mount with a center of rotation that coincides with the plane of the contacting surface between roller and bottom of the beam. The base of the cylindrical bearing surface shall include bolt holes to facilitate fixing the roller to the testing machine. The roller that is fixed against rotation about a longitudinal axis (Fig. 3 and Fig. 6) shall incorporate a similar mounting so that the total height is the same as the roller assembly shown in Fig. 2 and Fig. 5 and the beam is maintained level during a test. The barrel of each roller is fabricated from one piece of steel. Caps secure the roller barrel in place so that it may rotate but not displace during a test. The cylindrical seat of the roller that is free to rotate about a longitudinal axis shall include a flange and a recess as shown in Fig. 4 to prevent longitudinal translation during testing.

NOTE 3—The upper half of the cylindrical bearing surface is not fixed to the lower half, but is restrained by guides intended to prevent the upper part of the bearing from sliding in the longitudinal direction in response to the forces imposed by the beam as it deflects at the bottom surface and each half of the beam moves away from the center as the crack(s) widen.

NOTE 4—To check that a properly manufactured and lubricated journal bearing assembly is functional, the rotating roller within the assembly must turn at least 360° without undue resistance when turned by hand. Such a check should be performed before each test is undertaken.

5.2 *Steel Grade*—The rollers and their corresponding mountings shall be fabricated using SAE 4140 alloy steel or equivalent.

5.3 *Surface Treatment*—The sliding and rotating surfaces of the roller, bushings, and cylindrical bearing within the support mounting shall be machined to a high-grade machine finish with a roughness average of 0.8 μm [32 μin.] or better. The difference in radius between the contacting surface of the roller barrel and the corresponding contacting surface of the bushing is limited to 0.10 mm [0.004 in.].

5.4 *Lubrication*—The design includes grease ports for lubricating the sliding surfaces. Grease shall be applied to the surfaces via the grease ports to limit friction and expel debris that may collect at the junctions between the shaft of the roller and the bushing caps. The user shall establish a schedule for grease application to ensure proper operation of the roller assemblies. The grease shall be National Lubricating Grease Institute (NLGI) Grade 2 lithium complex molybdenum disulfide high-pressure grease as described in Specification D4950 or equivalent.

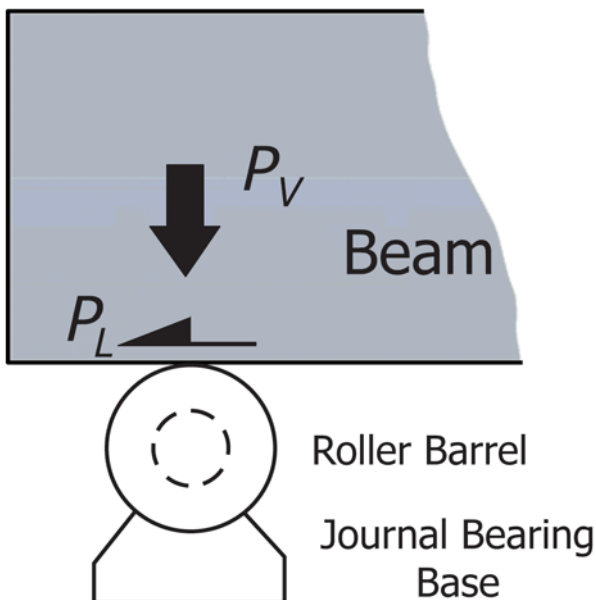

$P_L$  = frictional force applied to the roller by the beam.

$P_V$  = vertical force applied to the roller by the beam.

**FIG. 1 Forces Acting on a Supporting Roller During a Test**

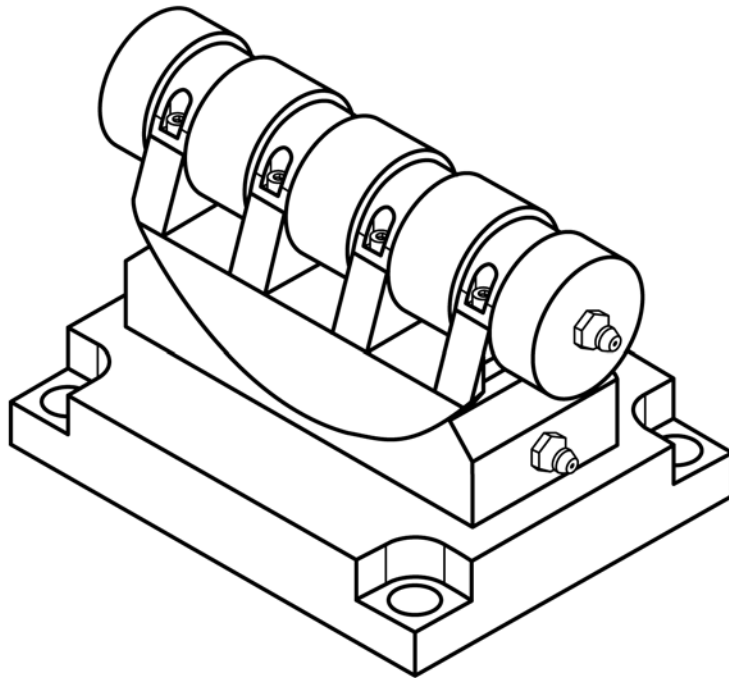

FIG. 2 General Arrangement Drawing of Supporting Roller with a Cylindrical Bearing Base

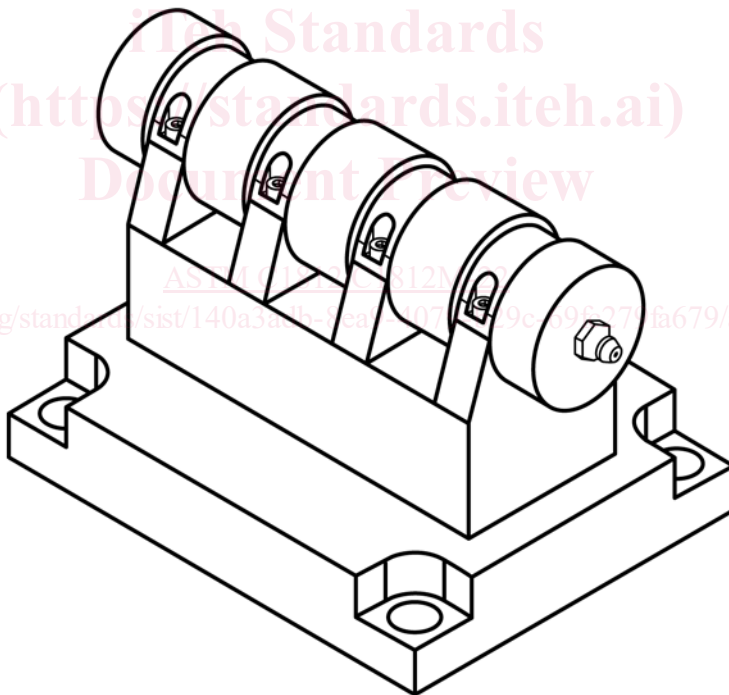

FIG. 3 General Arrangement Drawing of Supporting Roller with a Fixed Bearing Base

5.5 *Mounting of Rollers within Testing Machine*—The mounting shall include a 25 mm [1 in.] thick steel plate with bolts located so as to secure the roller supports to the test machine during testing. The designs shown in Figs. 2-6 incorporate four bolt holes in the base of the bearing mount

with an overall height of roller and mount equal to 100 mm [4.0 in.]. These dimensions have been found to perform satisfactorily in service, but the exact dimensions of the bases are permitted to be altered to suit the dimensions of the test machine to which they are fixed.

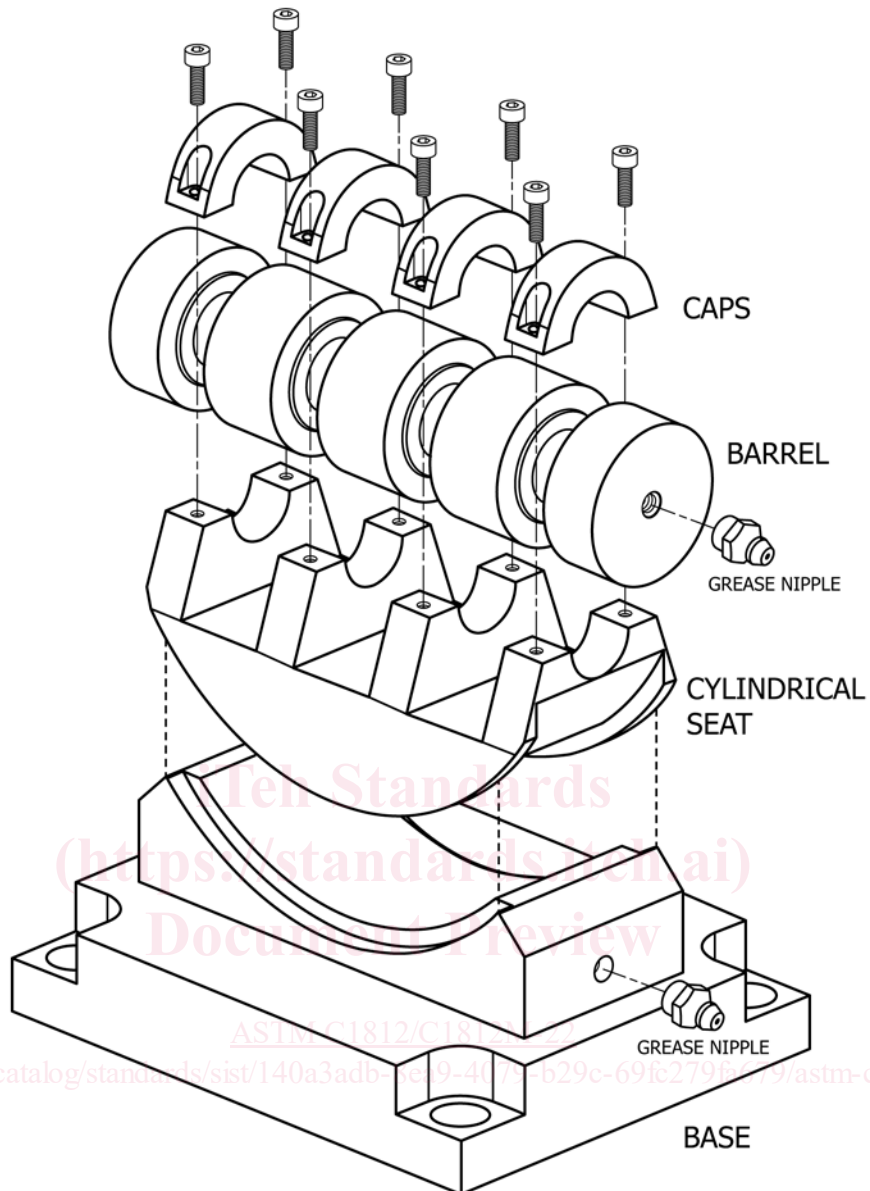

FIG. 4 Exploded View of Roller Assembly Showing Bushing Caps to Secure Roller Barrel and Flanges to Prevent Sliding in the Longitudinal Direction

5.6 *Dimensions*—The dimensions of the rollers shown in Figs. 5 and 6 are based on SI units. Equivalent dimensions in inches are listed in Table 1. Tolerances on dimensions are  $\pm 0.1$  mm [0.004 inches].

## 6. Keywords

6.1 fiber-reinforced concrete; flexural performance; friction; post-crack; residual strength; roller supports