



Designation: D3482 – 07a (Reapproved 2023)

Standard Practice for Determining Electrolytic Corrosion of Copper by Adhesives¹

This standard is issued under the fixed designation D3482; the number immediately following the designation indicates the year of original adoption or, in the case of revision, the year of last revision. A number in parentheses indicates the year of last reapproval. A superscript epsilon (ϵ) indicates an editorial change since the last revision or reapproval.

This standard has been approved for use by agencies of the U.S. Department of Defense.

1. Scope

1.1 This practice covers the determination of whether an adhesive has any corrosive effect on copper. It is ordinarily intended to distinguish materials that might cause corrosion in electrical and electronic equipment. This procedure is a subjective test for which precision and accuracy have not been established. It is not recommended for adhesives on backing.

1.2 The values stated in SI units are to be regarded as the standard. The values given in parentheses are for information only.

1.3 *This standard does not purport to address all of the safety concerns, if any, associated with its use. It is the responsibility of the user of this standard to establish appropriate safety, health, and environmental practices and determine the applicability of regulatory limitations prior to use.*

1.4 *This international standard was developed in accordance with internationally recognized principles on standardization established in the Decision on Principles for the Development of International Standards, Guides and Recommendations issued by the World Trade Organization Technical Barriers to Trade (TBT) Committee.*

2. Referenced Documents

2.1 *ASTM Standards:*²

D907 Terminology of Adhesives

D996 Terminology of Packaging and Distribution Environments

E104 Practice for Maintaining Constant Relative Humidity by Means of Aqueous Solutions

G15 Terminology Relating to Corrosion and Corrosion Testing (Withdrawn 2010)³

¹ This practice is under the jurisdiction of ASTM Committee D14 on Adhesives and is the direct responsibility of Subcommittee D14.80 on Metal Bonding Adhesives.

Current edition approved Jan. 1, 2023. Published January 2023. Originally approved in 1976. Last previous edition approved in 2014 as D3482 – 07a (2014). DOI: 10.1520/D3482-07AR23.

² For referenced ASTM standards, visit the ASTM website, www.astm.org, or contact ASTM Customer Service at service@astm.org. For *Annual Book of ASTM Standards* volume information, refer to the standard's Document Summary page on the ASTM website.

³ The last approved version of this historical standard is referenced on www.astm.org.

3. Terminology

3.1 *Definitions*—Definitions of terms in this test method may be found in Terminologies D907, D996, and G15.

3.1.1 *electrolytic corrosion, n*—the corrosion of metal resulting from current flow under an electrical potential in the presence of moisture.

4. Summary of Practice

4.1 Two parallel helices of fine copper wire are laid in etched grooves on a glass tube. The adhesive material is coated over the wires and the tube and then allowed to set or cure. The wired tube is exposed to high humidity with a d-c potential applied between the wires. Corrosion products are observed visually.

5. Significance and Use

5.1 Adhesives can be exposed to both electrical potential and humidity in many electrical and electronic applications. It is therefore desirable to provide a means of examining the corrosive tendencies of certain adhesives towards metals.

5.2 Although electrolytic corrosion is a direct result of ionic conduction in the adhesive, the nature of the exposed metals will have a bearing on both the severity of metal attack and the visibility of corrosion products. Because it gives a visual indication of corrosion and because of its widespread use in electrical circuits, copper is used in this practice. However, this would not preclude the use of other metals for specific interests.

5.3 This procedure is a subjective test in that determinations of the presence of corrosion is based on a visual inspection for a green discoloration or other evidence of corrosion.

6. Apparatus and Material

6.1 *Motor (Optional)*, low-speed, approximately 10 r/min for winding wire helices.

6.2 *Oven (or Temperature-Controlled Chamber)*, circulating-air, or chamber controlled at $39.5\text{ }^{\circ}\text{C} \pm 1\text{ }^{\circ}\text{C}$ ($95\text{ }^{\circ}\text{F} \pm 2\text{ }^{\circ}\text{F}$), unless otherwise specified.

6.3 *Battery, 45-V*, or equivalent source of d-c power.

6.4 *Corrosion Test Apparatus*—See Fig. 1.

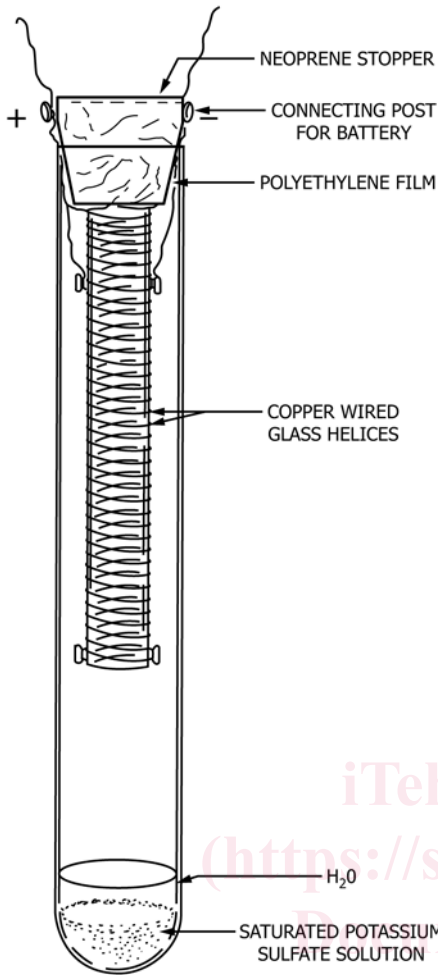

FIG. 1 Corrosion Test Apparatus

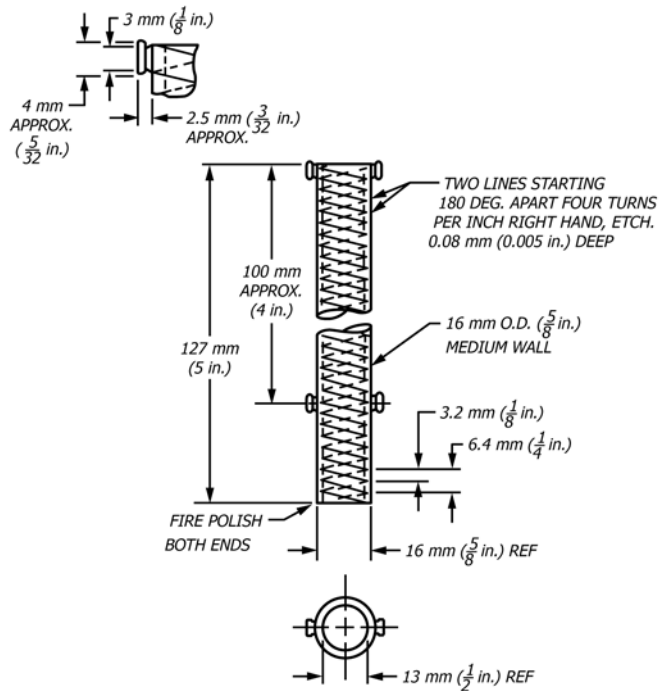

FIG. 2 Glass Tube

and insert the tube into a 16-mm ($\frac{5}{8}$ -in.) inside diameter by 13-mm ($\frac{1}{2}$ -in.) deep hole centered in the small end of a neoprene stopper.

7.5 Make solder connections of the helically wound wires to diametrically opposed connecting posts inserted in the neoprene stopper (Note 1). Clip excess wire from the opposite end of the tube.

NOTE 1—Short lengths of 14-gauge tinned copper wire have worked satisfactory as connecting posts.

7.6 Apply two thin uniform applications of the test adhesive in approximately 6 mm ($\frac{1}{4}$ in.) wide uniform stripes of the material to be tested 180° apart over the entire exposed length of the test apparatus. Allow the material to set or cure in accordance with the manufacturer's recommendations.

7.6.1 For adhesive systems which are air-inhibited or contain volatile, reactive constituents, wrap the test apparatus with a suitable nonadherent, inert film. Polyethylene, polypropylene, TFE-fluorocarbon, or similar films may be used. For air-inhibited adhesive systems, polyethylene and polypropylene are not recommended. If one of these films is used to cover the test adhesive, remove the nonadherent film from the test apparatus after the adhesive system has set or cured and before subjecting the specimen to humidity exposure.

NOTE 2—For extremely critical applications, room- and moderate temperature curing adhesives may be subjected to the testing environment during cure if mutually agreed.

7.7 Control temperature and relative humidity, when specified, in accordance with Practice E104, Method C.

NOTE 3—For example, for 96 % relative humidity at 35 °C (95 °F) place 2 g to 3 g of potassium sulfate in a test tube and cover with a