

# INTERNATIONAL STANDARD

**ISO**  
**5395**

First edition  
1990-10-25

---

---

**Power lawn-mowers, lawn tractors, lawn and  
garden tractors, professional mowers, and lawn  
and garden tractors with mowing  
attachments — Definitions, safety requirements  
and test procedures  
(standards.iteh.ai)**

*Tondeuses à gazon, à moteur, tracteurs de pelouse, tracteurs de jardin  
et de pelouse, tondeuses à usage professionnel, tracteurs de jardin et  
de pelouse avec équipements de tonte adaptables — Définitions,  
prescriptions de sécurité et modes opératoires d'essai*



Reference number  
ISO 5395:1990(E)

## Contents

	Page
<b>Section 1 General</b> .....	<b>1</b>
1.1 Scope .....	1
1.2 Normative references .....	1
1.3 Definitions .....	2
<b>section 2 Basic requirements</b> .....	<b>5</b>
2.1 Application .....	5
2.2 Safety protection .....	5
<b>section 3 Requirements for rotary mowers</b> .....	<b>10</b>
3.1 Application .....	10
3.2 General construction .....	10
3.3 Test procedures .....	12
3.4 Pedestrian-controlled machines: additional requirements ....	22
3.5 Ride-on (riding) machines: additional requirements .....	24
3.6 Towed units: requirements .....	25
3.7 Professional (commercial) mowers and turf care equipment: additional requirements .....	26
<b>section 4 Requirements for cylinder mowers</b> .....	<b>27</b>
4.1 Applications .....	27
4.2 General construction: guarding and shielding .....	27
4.3 Thrown grass, thrown objects, operator safety .....	27
4.4 Pedestrian-controlled machines: requirements .....	27
4.5 Ride-on (riding) machines: requirements .....	30
4.6 Towed units: requirements .....	30

iTeh STANDARD PREVIEW  
(standards.iteh.ai)

ISO 5395:1990  
<https://standards.iteh.ai/catalog/standards/sist/420a48d7-b3a9-423a-829d-a7d0cd03e929/iso-5395-1990>

© ISO 1990

All rights reserved. No part of this publication may be reproduced or utilized in any form or by any means, electronic or mechanical, including photocopying and microfilm, without permission in writing from the publisher.

International Organization for Standardization  
Case Postale 56 • CH-1211 Genève 20 • Switzerland

Printed in Switzerland

4.7 Professional (commercial) mowers and turf care equipment: additional requirements .....	30
--	----

## Annexes

<b>A</b> Guarding principles .....	31
<b>A.1</b> Safety distance from dangerous parts .....	31
<b>A.2</b> Round reach .....	31
<b>A.3</b> Reaching in and through elongated openings with parallel sides .....	33
<b>A.4</b> Reaching in and through square or circular apertures .....	34
<b>A.5</b> Openings of irregular shape .....	34
<b>B</b> Test enclosure .....	35
<b>B.1</b> Base .....	35
<b>B.2</b> Target composition .....	35
<b>C</b> Corrugated fibreboard penetration tests on rotary mowers: test enclosure wall panels .....	38
<b>C.1</b> Purpose .....	38
<b>C.2</b> Test fixture .....	38
<b>C.3</b> Fibreboard samples .....	38
<b>C.4</b> Procedure .....	38
<b>C.5</b> Recommended acceptance criteria .....	38
<b>D</b> Specimen test report of thrown object test .....	40
<b>D.1</b> Target elevation areas .....	40
<b>D.2</b> Data sheet .....	40
<b>D.3</b> Test acceptance (pass/fail criteria) .....	40
<b>E</b> Safety instructions for rotary mowers: pedestrian and ride-on, cylinder mowers: pedestrian and ride-on .....	42
<b>E.1</b> Safe operation practices for walk-behind rotary mowers .....	42
<b>E.2</b> Safe operation practices for ride-on (riding) rotary mowers .....	43
<b>E.3</b> Safe operation practices for walk-behind cylinder mowers .....	44
<b>E.4</b> Safe operation practice for ride-on (riding) cylinder mower machines .....	45
<b>F</b> Bibliography .....	46

iTeh STANDARD PREVIEW  
(standards.iteh.ai)  
ISO 5395:1990  
<https://standards.iteh.ai/catalog/standards/sist/420a48d7-b3a9-423a-829d-47d0e53951990>

## Foreword

ISO (the International Organization for Standardization) is a worldwide federation of national standards bodies (ISO member bodies). The work of preparing International Standards is normally carried out through ISO technical committees. Each member body interested in a subject for which a technical committee has been established has the right to be represented on that committee. International organizations, governmental and non-governmental, in liaison with ISO, also take part in the work. ISO collaborates closely with the International Electrotechnical Commission (IEC) on all matters of electrotechnical standardization.

Draft International Standards adopted by the technical committees are circulated to the member bodies for voting. Publication as an International Standard requires approval by at least 75 % of the member bodies casting a vote.

International Standard ISO 5395 was prepared by Technical Committee ISO/TC 23, *Tractors and machinery for agriculture and forestry*.

This first edition cancels and replaces the previous editions of separate parts: ISO 5395-1:1984, ISO 5395-2:1981, ISO 5395-3:1985 and its Addendum 1:1986, and ISO 5395-4:1985 of all of which it constitutes a revision and combination.

Annexes A, B, C, D and E form an integral part of this International Standard. Annex F is for information only.

# Power lawn-mowers, lawn tractors, lawn and garden tractors, professional mowers, and lawn and garden tractors with mowing attachments — Definitions, safety requirements and test procedures

## Section 1: General

### 1.1 Scope

This International Standard presents definitions of terms and specifies safety requirements and test procedures applicable to powered rotary and cylinder mowers, including pedestrian-controlled and ride-on (riding) types, ride-on (riding) lawn tractors, lawn and garden tractors, and lawn and garden tractors with mowing attachments designed primarily for use at and around the home.

The additional requirements for professional (commercial) mowers and turf care equipment are also given, in clause 3.7 and clause 4.7, for these machines designed primarily as professional (commercial) mowers and turf care equipment.

This International Standard does not apply to lawn trimmers, lawn edge trimmers, and edgers, flail mowers, sickle-bar mowers, agricultural mowers, and the electrical aspects of mains-electrically driven machines.

Rotary mowers are excluded from the requirements of this International Standard if the cutting means is either one or more non-metallic filaments, or one or more non-metallic cutting elements pivotally mounted on a generally circular central drive unit, where these cutting elements rely on centrifugal force to achieve cutting, and have a kinetic energy for each single cutting means of less than 10 J. In addition for these machines, the cutting means shall not be replaceable with metallic or other rigid material equivalents supplied by the manufacturer.

### 1.2 Normative references

The following standards contain provisions which, through reference in this text, constitute provisions of this International Standard. At the time of publication, the editions indicated were valid. All standards are subject to revision, and parties to agreements based on this International Standard are encouraged to investigate the possibility of applying the most recent editions of the standards indicated below. Members of IEC and ISO maintain registers of currently valid International Standards.

ISO 500:1979, *Agricultural tractors — Power take-off and drawbar — Specification.*

ISO 2758:1983, *Paper — Determination of bursting strength.*

ISO 3304:1985, *Plain end seamless precision steel tubes — Technical conditions for delivery.*

ISO 3305:1985, *Plain end welded precision steel tubes — Technical conditions for delivery.*

ISO 3306:1985, *Plain end as-welded and sized precision steel tubes — Technical conditions for delivery.*

ISO 3411:1982, *Earth-moving machinery — Human physical dimensions of operators and minimum operator space envelope.*

ISO 3416:1986, *Textile floor coverings — Determination of thickness loss after prolonged, heavy static loading.*

iTeh STANDARD PREVIEW  
(standards.iteh.ai)

ISO 3600:1981, *Tractors and machinery for agriculture and forestry — Operator manuals and technical publications — Presentation.*

ISO 3767-1:1982, *Tractors, machinery for agriculture and forestry, powered lawn and garden equipment — Symbols for operator controls and other displays — Part 1: Common symbols.*

ISO 3767-2:1982, *Tractors, machinery for agriculture and forestry, powered lawn and garden equipment — Symbols for operator controls and other displays — Part 2: Symbols for agricultural tractors and machinery.*

ISO 3767-3:1988, *Tractors, machinery for agriculture and forestry, powered lawn and garden equipment — Symbols for operator controls and other displays — Part 3: Symbols for powered lawn and garden equipment.*

ISO 3789-1:1982, *Tractors, machinery for agriculture and forestry, powered lawn and garden equipment — Location and method of operation of operator controls — Part 1: Common controls.*

ISO 3789-3:1989, *Tractors, machinery for agriculture and forestry, powered lawn and garden equipment — Location and method of operation of operator controls — Part 3: Controls for powered lawn and garden equipment.*

ISO 4200:1990<sup>1)</sup>, *Plain end steel tubes, welded and seamless — General tables of dimensions and masses per unit length.*

ISO 6682:1986, *Earth-moving machinery — Zones of comfort and reach for controls.*

ISO 9193:1990, *Lawn and garden ride-on (riding) tractors — Power take-off.*

IEC 335-1:1976, *Safety of household and similar electrical appliances — Part 1: General requirements.*

### 1.3 Definitions

For the purposes of this International Standard, the following definitions apply.

**1.3.1 blade:** (See 1.3.6.)

**1.3.2 blade tip circle:** Path described by the outermost point of the cutting means cutting edge as it rotates about its shaft axis.

**1.3.3 braking distance:** Distance travelled between the point of the first application of the brake control

and the point at which the machine or component comes to rest.

**1.3.4 braking system:** Combination of one or more brakes and related means of operation and control.

**1.3.5 control:** Means or device which will control the operation of the mower or any specific operating function thereof.

**1.3.6 cutting means:** Mechanism used to provide the cutting action of a power lawn-mower.

**1.3.7 cutting means enclosure [housing]:** Part or assembly which provides the protective means around the cutting means.

**1.3.8 cutting position:** Any height setting of the cutting means designated by the manufacturer for cutting grass.

**1.3.9 cutting width:** Width of cut measured across the cutting means at right-angles to the direction of travel and calculated from the dimensions of the cutting means or the diameter(s) of the blade tip circle(s).

**1.3.10 cylinder [reel] mower:** Grass-cutting machine with one or more blades rotating about a horizontal axis to provide a shearing action with a fixed cutter bar or knife.

**1.3.11 discharge chute:** Extension of the cutting means enclosure from the discharge opening, generally used to control the discharge of material from the cutting means.

**1.3.12 discharge opening:** Gap or opening in the cutting means enclosure through which grass may be discharged.

**1.3.13 durable label:** Label that is considered to be virtually permanent.

**1.3.14 edger:** Powered machine suitable for cutting lawn and soil, usually in a vertical plane.

**1.3.15 exhaust system:** Means of conveying exhaust gases from the engine exhaust port to the atmosphere.

**1.3.16 flail mower:** Grass-cutting machine with a multiplicity of free-swinging cutting elements that rotate about an axis parallel to the cutting plane and cut by impact.

**1.3.17 grass catcher:** Part or combination of parts which provides a means for collecting grass clippings or debris.

1) To be published.

**1.3.18 guard; shield:** Part of the mower or a component incorporated to provide protection for the operator and/or bystander.

**1.3.19 hit:** Test projectile passing completely through all layers of the test target material.

**1.3.20 Jackknifing:** Movement of an articulated unit which results in

- a) prevention of further operation in the reverse direction, or
- b) entrapment of the operator, or
- c) displacement of the operator sufficient to cause loss of control.

**1.3.21 lawn edge trimmer:** Powered grass-cutting machine for trimming lawn edges usually in a vertical plane.

**1.3.22 lawn trimmer:** Powered grass-cutting machine where the operator determines the plane of operation of the cutting means and the height of cut, possibly assisted by a wheel or skid, etc.

**1.3.23 maximum operating engine [motor] speed:** Highest engine/motor speed obtainable when adjusted in accordance with mower manufacturer's specifications and/or instructions with the cutting means engaged, taking into account all tolerances.

**1.3.24 mowing attachment:** Cutting means designed to be easily detached from the machine, generally to allow the machine to be used for other purposes.

**1.3.25 mulching mower:** Rotary mower without discharge openings in the mower housing.

**1.3.26 normal operation:** Any use of the machine which is reasonably foreseeable, as seen by the ordinary user, and which is consistent with such activities as cutting grass, starting, stopping, fuelling, or connecting to (or disconnecting from) a power source, or the mounting of, and dismounting from, ride-on machines.

**1.3.27 normal use:** Normal operation, plus routine maintenance, servicing, cleaning, transporting, attaching or removing accessories, and making ordinary adjustments as determined by the manufacturer's instructions.

**1.3.28 operator control:** Any control requiring operator actuation to perform specific functions.

**1.3.29 operator control position:** Area or space within which all controls to be operated from the operator position shall be located. See ISO 6682.

**1.3.30 operator presence control:** Control designed so that it will automatically interrupt power to a drive when the operator's actuating force is removed.

**1.3.31 operator target area:** Operator target area for pedestrian-controlled machines as specified in 3.3.1.4.

**1.3.32 operator zone — pedestrian:** Operator zone for persons operating a pedestrian-controlled machine as shown in figure 2.

**1.3.33 operator zone — ride-on:** Operator zone for persons operating ride-on machines as described in ISO 6682.

**1.3.34 parking brake:** Means of preventing a stationary machine from moving that can remain applied without the operator being present.

**1.3.35 pedestrian-controlled mower; walk-behind mower:** Grass-cutting machine, either pushed or self-propelled, normally controlled by the operator walking behind the unit.

**1.3.36 pedestrian-controlled tractor; walk-behind tractor:** Machine normally controlled by an operator walking behind the unit, designed to power and propel a variety of attachments.

**1.3.37 power (lawn-) mower:** Grass-cutting machine where the cutting means operates in a plane approximately parallel to the ground and which uses the ground to determine the height of cut by means of wheels, air cushion or skids, etc., and which utilizes an engine or an electric motor as a power source.

**1.3.38 power source:** Engine or motor which provides mechanical energy for linear or rotational movement.

**1.3.39 professional [commercial] mower:** Machine designed for commercial application that is generally used by a paid operator.

**1.3.40 ride-on [riding] machine; lawn and garden tractor; turf (riding) tractor:** Self-propelled machine on which an operator rides and designed primarily for cutting grass and auxiliary garden work. The cutting means may be an integral part of the machine or suspended from or attached to the machine.

**1.3.41 rotary mower:** Power mower in which one or more elements, cutting by impact, rotate about an axis normal to the cutting plane.

**1.3.42 service brake system:** Designated primary means for decelerating and stopping a machine from its ground travel speed.



**1.3.43 sickle bar mower:** Lawn-mower which uses a power source to create reciprocating movement in a knife or knives to provide a shearing action with a stationary cutter bar or movable knife.

**1.3.44 standard test operator:** Operator weighing 75 kg  $\pm$  5 kg, and 1,75 m  $\pm$  0,05 m tall.

**1.3.45 stopping time:** Time elapsed between the instant at which stopping action is actuated and the instant at which the machine or component comes to a stop.

**1.3.46 throw line (of cylinder mowers):** Steepest line in a vertical plane, tangential to the periphery of the cutting cylinder in the direction of rotation, which does not intersect a guard or portion of the mower. See figure 18.

**1.3.47 thrown object hazard:** Potential for injury caused by object(s) propelled by the moving cutting means.

**1.3.48 towed unit:** Implement pulled from the drawbar of a propelling machine and usually equipped with wheels for transport.

**1.3.49 traction drive:** Means or system used to transmit power from the power source to the ground drive means.

**1.3.50 trailing seat; sulky:** Removable, trailing device designed to carry a seated operator to ride behind while controlling a self-propelled, walk-behind mower or tractor.

**1.3.51 trailing seat unit; sulky unit:** Walk-behind power lawn-mower or tractor with an optional trailer seat (sulky) attached.

**1.3.52 transport position:** Designated condition of the cutting means of a power lawn-mower for propelled transport.

## iTeh STANDARD PREVIEW (standards.iteh.ai)

ISO 5395:1990

<https://standards.iteh.ai/catalog/standards/sist/420a48d7-b3a9-423a-829d-a7d0cd03e929/iso-5395-1990>



## Section 2: Basic requirements

### 2.1 Application

Section 2 specifies the basic requirements for powered rotary and cylinder (reel) mowers, including pedestrian-controlled and ride-on (riding) types, ride-on (riding) lawn tractors, lawn and garden tractors, professional mowers, and lawn and garden tractors with mowing attachments.

### 2.2 Safety protection

#### 2.2.1 Power-driven components

**2.2.1.1** Power-driven gears, chains, sprockets, belts, friction drives, pulleys, fans, fan wheels and other moving parts, whenever they create a pinch point capable of causing injury during normal operating of the machine, shall be positioned or guarded by shields or similar attachments to prevent accidental contact with these components.

Driving belts and chains having connectors which are capable of causing injury, during normal operating of the machine, shall be guarded along their whole length. Other belt or chain drives which are capable of causing injury, during normal operating of the machine, shall be guarded at least at the run-on points. Drive-shafts shall be fully guarded.

The principles set out in annex A shall be followed when developing a guarding system.

Rotating covers or discs shall have a continuous unbroken or smooth surface. Mowers shall not be equipped with a starter operated by means of a loose rope.

Guards shall be provided to prevent accidental contact with hazardous servicing points when servicing the machine as recommended by the manufacturer.

Where a guard is designed to be opened or removed and which exposes a hazard, a safety sign warning of the hazard shall be located on the guard or adjacent to the hazard.

Where a guard is so positioned that it may be used as a step, it shall withstand a force of 1 200 N.

**2.2.1.2** The requirements of 2.2.1.1 do not apply to

- a) the cutting means; and
- b) any component part functioning in contact with the soil.

#### 2.2.2 Guard attachment

All guards shall be permanently attached to the machine and shall not be detachable without the use of tools. The opening of guards shall require the use of a tool. Exceptions to this are the opening of or removing interlocked guards which disable the protected moving parts, the opening of hinged guards for grass discharge chutes and engine compartment access.

#### 2.2.3 Heat protection

##### 2.2.3.1 Requirements

A guard or shield shall be provided to prevent accidental contact with any exposed engine exhaust components greater than 10 cm<sup>2</sup> and with a hot surface greater than 80 °C at 20 °C ± 3 °C ambient temperature during normal operation of the machine.

##### 2.2.3.2 Test equipment

The measuring equipment shall have an accuracy of ± 3 °C.

##### 2.2.3.3 Test method

The test shall be conducted in the shade. The engine shall be operated at its maximum no-load speed until the surface temperature stabilizes. Temperatures are to be determined by correcting the observed temperature by the difference between the specified ambient and the test ambient temperature. Identify the hot surface area(s) on the engine exhaust system. When the distance between the identified hot area and the nearest control is in excess of 100 mm, cone A in figure 1 shall be used. For a distance less than 100 mm between the identified hot area and the nearest control, cone B in figure 1 shall be used.

Move the cone, with the axis of the cone anywhere between 0° and 180° to the horizontal with the nose or point of the cone in a downward to horizontal direction towards the hot surface. The cone shall not be moved upwards. When moving the cone, determine if contact is made with the hot surface area(s) with the cone tip or conical surface of the cone.

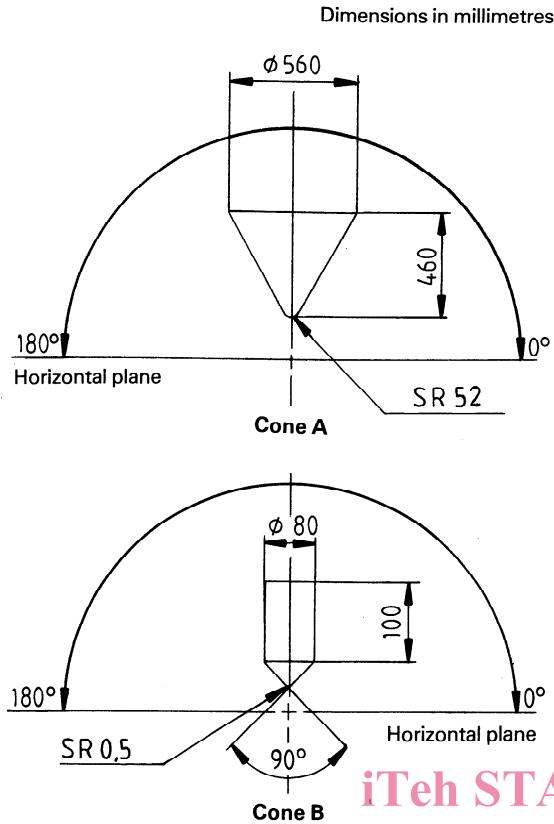

Figure 1 — Test cones

## 2.2.7 Liquid containers

When filled to the manufacturer's instructions, liquid containers, batteries, fuel systems, oil reservoirs, and coolant systems shall be constructed to prevent spillage for 1 min after the machine is tilted as specified in the stability test. Weeping at vent systems is not considered spillage.

## 2.2.8 Seats and foot-rests

Ride-on machines shall be provided with an operator seat and foot-rests of adequate strength with safe access to and from the operator position. The operator's seat shall have a buttock support at least 115 mm high at the rear above the seating surface to retain the operator, except where the operator sits astride the frame of the machine and holds the handlebars in which case the buttock support is not required.

## 2.2.9 Controls

### 2.2.9.1 All machines

Operator controls shall meet the requirements specified in ISO 3789-1 and ISO 3789-3. The controls shall also accommodate the 5th to the 95th percentile adult operator as specified in ISO 3411.

The following are not operator controls:

- height of cut setting;
- fixed blade (on-cut) setting or adjustment on cylinder mowers;
- engine starting;
- grass catcher discharge arrangements.

### 2.2.9.1.1 Pedestrian-controlled machines

The location and range of movement of operator controls shall be convenient to the operator and shall remain within the anthropometric dimensions given in figure 2 for walk-behind units. The operating range of less frequently used controls may be extended by allowing the operator's trunk, when standing with both feet on the ground, to articulate within the confines of the operator zone, e.g., lean forward until contacting the handle in any of the operating positions.

Engine starting controls may be outside this range if

- a) starting can only be accomplished with blade drive disengaged; or

### 2.2.3.4 Test acceptance

The tip or conical surface of cone A or B shall not make contact with the hot surface of the exhaust system.

## 2.2.4 Protection from exhaust fumes

Engine exhaust, where it exists, shall not be directed towards the operator.

On machines equipped with an enclosure for the operator, the engine exhaust shall not be directed towards the enclosure or the air inlet to the enclosure.

## 2.2.5 Moving components

Any moving components shall not cause injury to, or unstable displacement of, the operator during normal operation.

## 2.2.6 Pressurized components

Pressurized hoses, lines and components shall be located or shielded so that in the event of rupture the fluid is not discharged directly on to the operator when in the operator position.

- b) the mower housing can pass the foot probe test in 3.3.5 with the probe applied at the designated starting position of the mower.

Dimensions in millimetres

The reverse function of the traction drive control(s) shall require continuous activation in the direction of travel to drive, and shall automatically return to neutral when released.

On self-propelled mowers, it shall be possible to engage or disengage the traction drive when the cutting means is operating.

#### 2.2.9.1.2 Ride-on (riding) machines

The location and range of movement of operating controls shall be convenient to the operator and shall remain within the confines of the operator zone of reach in ISO 6682. The operating range of less frequently used controls may be extended by allowing the operator's trunk, while sitting on ride-on machines, to articulate within the confines of the operator area, e.g., lean forward until contacting steering control which may be in any of the operator positions.

#### 2.2.9.2 Identification of controls

Controls, other than those the purpose of which is obvious, shall have the function, direction and/or method of operation clearly identified by a durable label or mark.

Easily understood detailed instructions on the operation of all controls shall be provided in an operator's manual.

#### 2.2.9.3 Operator symbols

Operator symbols shall be in accordance with ISO 3767-1, ISO 3767-2 and ISO 3767-3.

#### 2.2.10 Machine identification

##### 2.2.10.1 General

Every machine and mowing attachment shall be permanently identified indicating the manufacturer or supplier, model number and/or serial number.

##### 2.2.10.2 Label

Labels provided for identification and directional or cautionary information shall have a reasonable life for the anticipated machine operating environment and satisfy the following requirements:

- a) the label shall have a durable bond with the base material surface;

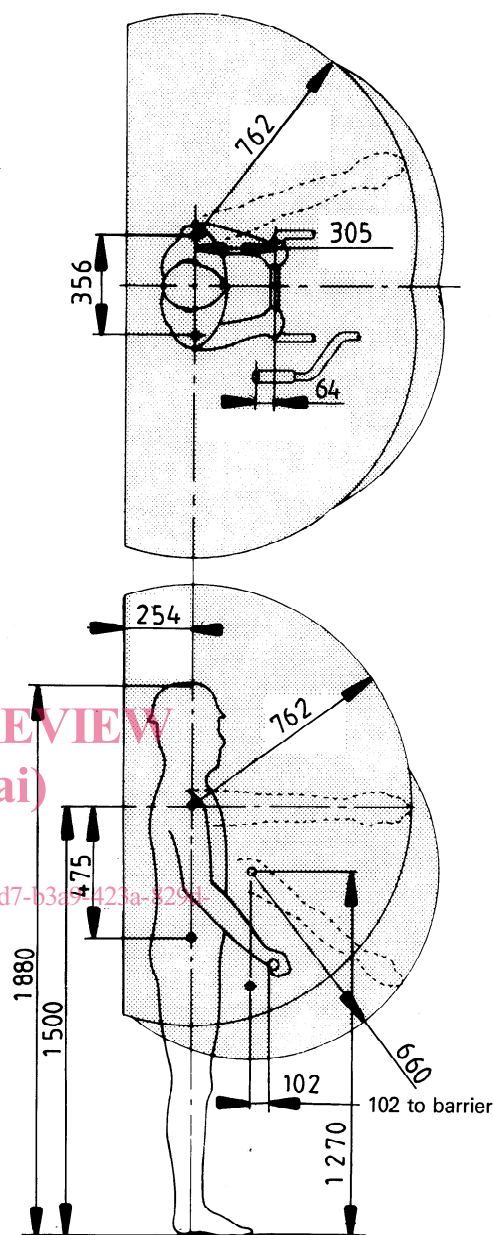

#### NOTES

- 1 The operator zone is the area into which the extremities of a 95th percentile male can reach from the normal operator position.
- 2 The lower forward zone is the area into which a 5th percentile male or a 50th percentile female can reach when against the handle barrier. This zone can also be reached by a 95th percentile male leaning forward against the handle barrier.
- 3 All barriers within the operator zone will reduce the zone by the space occupied and protected by the barrier.
- 4 The operator zone includes the maximum range of all frequently used operator control movement but is not intended to represent preferred operator control positions.

Figure 2 — Operator zone — Walk-behind pedestrian-controlled machine

- b) the label shall be weather-resistant and under normal cleaning procedures shall not fade, discolour, crack, craze or blister, and shall remain legible;
- c) the label shall not curl at the edges and legibility shall not be affected by spilled petrol or oil;
- d) the label, other than those on electric machines, shall withstand high-pressure cold water cleaning.

Labels (danger signs) giving cautionary information shall be located close to the relevant hazard. Such danger signs and warning signs shall either be in the official language(s) of the country in which the mower is sold, or use applicable information pictorials.

### 2.2.11 Maintenance and operational requirements

Each mower shall be provided with a manual giving operating, servicing, and maintenance instructions, as specified in ISO 3600. The instructions should include those operations which can normally be performed by the operator.

The instructions shall include:

- a) instructions for the proper assembly of the mower for use, if the mower is not supplied in a completely assembled form;
- b) instructions for proper adjustment of the machine, including a warning of the danger of rotating blade(s), for example, "Caution — do not touch rotating blade";
- c) instructions for machine operation and where appropriate such items as:
  - instructions for de-energizing stored energy devices, such as spring-loaded mechanisms, engine cooling system and hydraulic systems including hydraulic accumulators,
  - information that hydraulic fluid escaping under pressure can have sufficient force to penetrate the skin and do serious damage, and that if fluid is injected into the skin, it must be surgically removed within a few hours by a doctor familiar with this form of injury, or gangrene may result.

## 2.2.12 Electrical requirements

### 2.2.12.1 General

These electrical requirements apply only to battery circuits of less than 42 V and are given for guidance. For the electrical requirements for mains-connected

electrically driven machines, reference should be made to IEC 335-1.

### 2.2.12.2 Low-voltage battery circuits (not including magneto grounding circuits)

#### 2.2.12.2.1 Electrical cables

Electrical cables shall be protected if located in potentially abrasive contact with metal surfaces.

The wiring assembly shall, where possible, be grouped together, be properly supported, and be located so that no portion is in contact with the carburettor, metallic fuel lines, the exhaust system, moving parts or sharp edges. Any edges of metal members likely to be in contact with the cables shall be rounded or protected to prevent possible damage to the cables by cutting or abrasion.

#### 2.2.12.2.2 Battery installation

The compartment for a vented storage battery shall have openings to provide ventilation and drainage. When the battery is in the operating position, acid shall not leak onto parts that would be critically affected to the extent that a hazard would be created from corrosion.

#### 2.2.12.2.3 Overload protection

All circuits, except starter motor and high-tension ignition circuits, shall be provided with overload protection devices in the ungrounded line near the battery terminal or starter cable. The overload protection may be located in either wire of a two-wire system.

This requirement shall not, however, apply to battery-powered machines capable of passing the following test.

With the motor shaft locked to prevent rotation, connect it to its fully charged integral battery, and leave it in that condition until the battery is discharged or failure of any component takes place. The machine shall not emit flames or molten metal. Any internal explosion shall be contained so as not to cause any material to be ejected from the machine.

#### 2.2.12.2.4 Terminals and uninsulated electrical parts

Terminals and uninsulated electrical parts, and two-wire non-grounded systems shall be protected against short-circuiting by the fuel-tank, or tools, during normal refuelling and lubrication servicing.

### 2.2.12.3 Ignition circuits

**2.2.12.3.1** Ignition interruption or short-circuiting shall be provided and shall be fitted on the low-voltage side.

**2.2.12.3.2** All high-voltage parts of the circuit including spark-plug terminals shall be electrically protected in such a manner that the operator cannot make accidental contact with them.

### 2.2.13 Engine stopping and starting

**2.2.13.1** An engine-stopping device shall be provided. The device shall not depend on sustained manual pressure for its continued operation. This device shall require manual and intentional activation in order to restart the engine, and shall be accessible from starting and operating positions.

**2.2.13.2** A switch operated by a removable key, or a similar device shall be provided to prevent unauthorized starting of the engine unless a manual starter is the only means of engine starting.

### 2.2.14 Transport

**2.2.14.1** If movement of the cutting means towards the transport position raises any part of the cutting plane above 400 mm from the ground, then the drive shall be automatically disengaged or require manual disengagement before it can be raised above 400 mm.

**2.2.14.2** When moving the cutting means from the transport position to the working position the drive to the cutting means shall not be engaged unless

- a) the operator is at the operator's position;
- b) all parts of the cutting plane are within 400 mm of the ground; and
- c) there is a deliberate activation of the drive to the cutting means by the operator.

**2.2.14.3** When there is a designated transport position, and where the height of any part of the cutting plane of a cutter unit is less than 400 mm, there shall be a means of disengaging the cutting means drive while the traction drive is engaged.

**2.2.14.4** The cutter unit shall be capable of being secured in the transport position by positive means such as latches, hydraulic locks, etc.

**2.2.14.5** If the cutter units have to be brought to the transport position by hand, they shall be provided with appropriate handles.

**2.2.14.6** For ride-on units the operation of the cutting means shall be independent of the traction drive and shall include a separate control for engaging and disengaging the traction drive.



## Section 3: Requirements for rotary mowers

### 3.1 Application

Section 3 specifies the safety requirements and test procedures applicable to powered rotary mowers, including pedestrian-controlled and ride-on (riding) types, ride-on (riding) lawn tractors, lawn and garden tractors, professional mowers, and lawn and garden tractors with mowing attachments.

### 3.2 General construction

#### 3.2.1 Blade enclosure

##### 3.2.1.1 General

The blade enclosure shall extend at least 3 mm below the plane of the blade tip circle, except as allowed in 3.2.1.2, and the grass discharge opening. The bolt heads of blade-securing screws may extend below the blade enclosure providing these are located within the inner 50 % blade tip circle diameter.

Any extension of the wall(s) of the blade enclosure adjacent to the discharge opening, including walls of the discharge chute, not meeting this requirement shall be considered as part of the discharge opening. The wall(s) shall be tested by the foot probe (3.3.5) and meet all the other requirements of this International Standard.

##### 3.2.1.2 Front opening

Front openings may be provided on machines having a cutting width of 600 mm or greater.

Where provided it shall not exceed

- a) the cutting width; or
- b) the opening generated by two radial lines extending from the blade spindle(s) centre(s) at an angle of 50° to the direction of travel where these lines meet the enclosure, whichever is the smaller. See figure 3.

The highest point of all openings in the blade enclosure at the front, except the discharge openings, shall be limited by a vertical angle of opening of 15° and a maximum distance of 30 mm above the horizontal plane of the blade in the lowest blade position. The highest point in the openings of a front comb or rake arrangement shall be considered as a point on the bottom edge of the blade enclosure, front. See figure 3.

#### 3.2.2 Discharge openings (chutes)

When open discharge chutes are provided, the extension of the discharge chute perimeters shall not intersect the operator target area when the mower is set at any height of cut. No tangential line from the blade tip circle shall intersect the operator target area without first contacting the blade enclosure or guard.

#### 3.2.3 Guards and grass catchers

Swinging guards or guards which have to be displaced in order to fit the grass catcher shall automatically return to the full guard position when the grass catcher is removed. The guards shall be considered as forming part of the blade enclosure for the purposes of 3.2.1 and 3.2.2.

Instructions shall be affixed to the mower near the discharge opening and to the grass catcher adapter, if one is used, stating that the mower shall not be operated without either the entire grass catcher or the guard in place.

#### 3.2.4 Blades

##### 3.2.4.1 Operator presence control

###### 3.2.4.1.1 Pedestrian-controlled machines

Pedestrian-controlled machines shall be fitted with a device on the control handle which will automatically stop blade rotation when the operator's hands are removed from the handle: this may be accomplished either by stopping the drive motor or by an intermediate blade clutch/brake mechanism. For re-starting blade rotation, the control shall require two separate actions. If these actions are to be carried out using the same hand, then the actions shall be totally distinct thereby preventing accidentally switching on.

###### 3.2.4.1.2 Ride-on machines

Ride-on machines shall be fitted with a device which will automatically stop the blade rotation when the operator leaves the normal operating position. If the operator returns to the operator's position before the blades have stopped, the blades may automatically resume operation. Blades starting shall require intentional reactivation by a means other than the operator presence control after stopping.

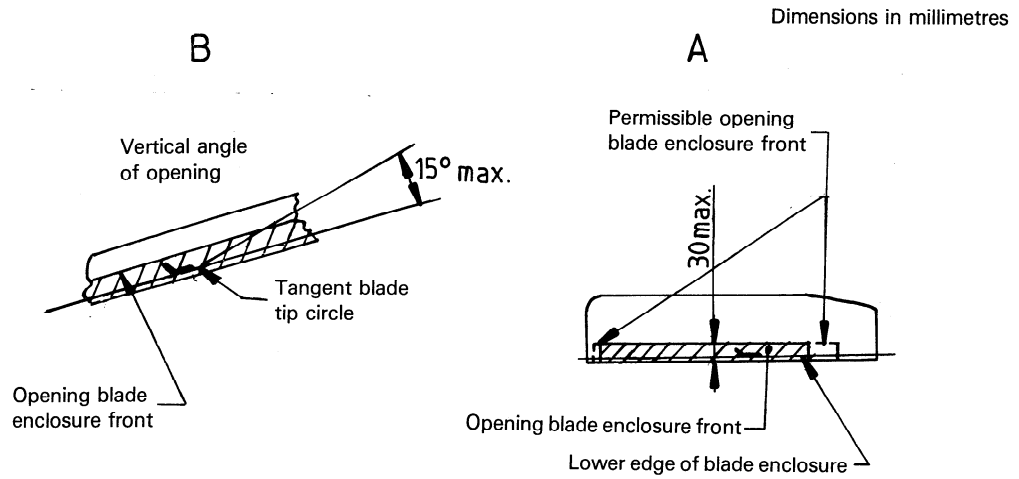

Views A and B apply to both single and multispindle mowers

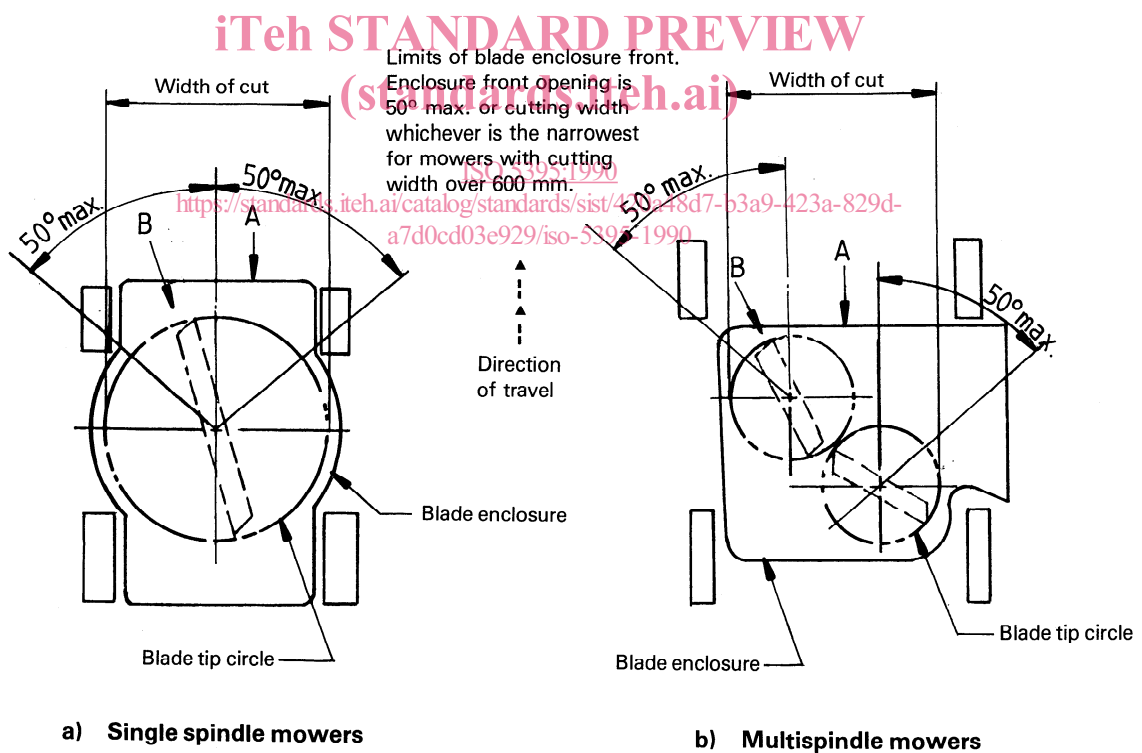

Figure 3 — Front opening restrictions