



Designation: F791 – 18 (Reapproved 2023)

# Standard Test Method for Stress Crazing of Transparent Plastics<sup>1</sup>

This standard is issued under the fixed designation F791; the number immediately following the designation indicates the year of original adoption or, in the case of revision, the year of last revision. A number in parentheses indicates the year of last reapproval. A superscript epsilon ( $\epsilon$ ) indicates an editorial change since the last revision or reapproval.

*This standard has been approved for use by agencies of the U.S. Department of Defense.*

## 1. Scope

1.1 This test method covers the determination of the critical crazing stress for a transparent plastic material when exposed to a specific solvent, chemical, or compound at a specific temperature.

1.2 *This standard does not purport to address all of the safety concerns, if any, associated with its use. It is the responsibility of the user of this standard to establish appropriate safety, health, and environmental practices and determine the applicability of regulatory limitations prior to use.*

1.3 *This international standard was developed in accordance with internationally recognized principles on standardization established in the Decision on Principles for the Development of International Standards, Guides and Recommendations issued by the World Trade Organization Technical Barriers to Trade (TBT) Committee.*

## 2. Referenced Documents

2.1 *ASTM Standards:*<sup>2</sup>

D618 Practice for Conditioning Plastics for Testing

E691 Practice for Conducting an Interlaboratory Study to Determine the Precision of a Test Method

2.2 *Other Method:*

ARTC (Aircraft Research and Testing Committee of the Aircraft Industries Association of America, Inc.) Conditioning Method<sup>3</sup>

## 3. Terminology

3.1 *Definitions of Terms Specific to This Standard:*

3.1.1 *crazing*—a group of surface fissures that appear to be small cracks in the material, although they are not.

<sup>1</sup> This test method is under the jurisdiction of ASTM Committee F07 on Aerospace and Aircraft and is the direct responsibility of Subcommittee F07.08 on Transparent Enclosures and Materials.

Current edition approved Jan. 1, 2023. Published January 2023. Originally approved in 1982. Last previous edition approved in 2018 as F791 – 18. DOI: 10.1520/F0791-18R23.

<sup>2</sup> For referenced ASTM standards, visit the ASTM website, [www.astm.org](http://www.astm.org), or contact ASTM Customer Service at [service@astm.org](mailto:service@astm.org). For *Annual Book of ASTM Standards* volume information, refer to the standard's Document Summary page on the ASTM website.

<sup>3</sup> Available from Aircraft Industries Association, 1725 DeSales St. NW, Washington, DC 20034.

3.1.1.1 *Discussion*—Crazing is a form of yielding in polymers characterized by a spongy void filled fibrillar structure. The density in the craze changes resulting in a change in the index of refraction, which causes light to be reflected off of the crazes. This light reflection causes the crazes to sparkle when viewed from certain angles. The crazes are sometimes random and scattered with varied lengths and depths but usually are oriented perpendicular to a tensile stress. Crazing is difficult to detect. It becomes more pronounced when viewed with a light source that is at an oblique angle.

## 4. Significance and Use

4.1 This test method provides a guide for evaluating whether a specific solvent, chemical, or compound is detrimental to a transparent plastic as a result of a manufacturing process, a fabrication operation, or the operational environment. All transparent plastics are susceptible to crazing, though in widely varying degree and from a variety of causes. This test method is intended to allow establishment of the crazing stress when the simultaneous action of both load and a material that will cause crazing is applied, producing non-reversible damage that limits the usage of that transparent plastic in a specific application.

## 5. Apparatus

5.1 *Test Fixture*, with fluorescent light source illustrated and constructed as shown in [Figs. 1 and 2](#).

5.2 *Drill Fixture* constructed as shown in [Fig. 3](#).

5.3 *Marking Fixture*, constructed as shown in [Fig. 3](#).

5.4 *Portable Specimen Rack*, constructed in the manner as shown in [Fig. 4](#) for handling and conditioning test specimens.

5.5 *Weights*—A container and shot for the application of weight on the rack as shown in [Fig. 1](#).

5.6 *Filter Paper*, quantity of 0.50 in. by 1.0 in. (12.7 mm by 25.4 mm) pieces of filter, medium-retention filter paper.

## 6. Test Specimens

6.1 The test specimen shall be machined from the transparent plastic material to be evaluated. A minimum of six

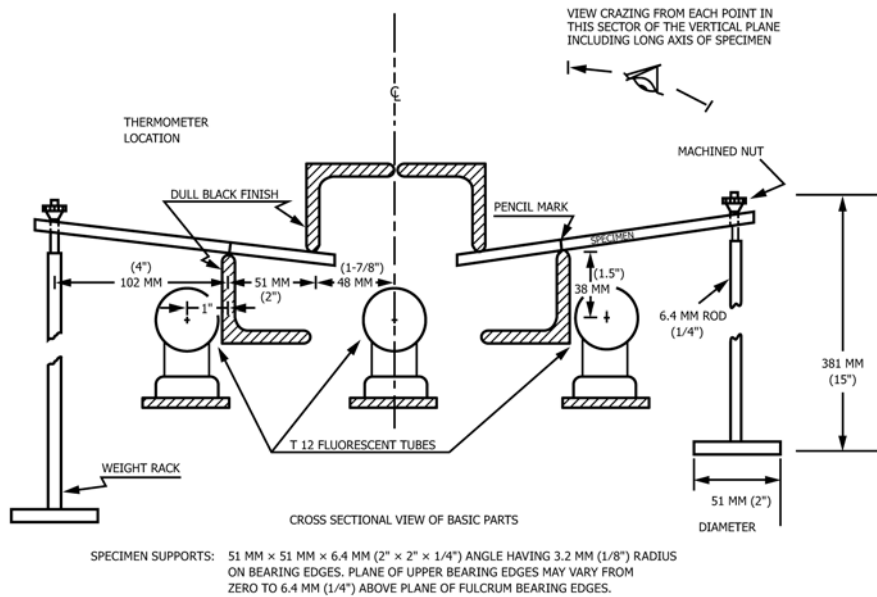

FIG. 1 Accelerated Craze Test Fixture

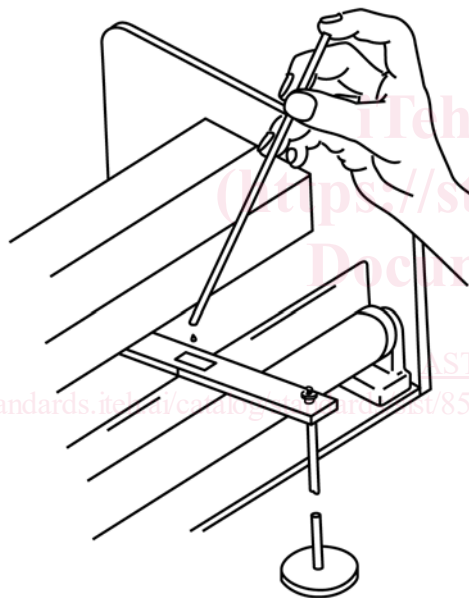

FIG. 2 Application of Test Liquid to Piece of Filter Paper on Top Surface of Test Specimen

specimens for each solvent, chemical, or compound is required. The preferred transparent plastic sheet material thickness is 6.35 mm ± 0.64 mm (0.250 in. ± 0.025 in.). Other thickness material is acceptable, but the actual thickness must be recorded. Orientation of each test specimen within the test sheet or part must be recorded.

6.2 The test specimens shall be 25.4 mm ± 0.8 mm (1.00 in. ± 0.03 in.) wide by 177.8 mm ± 1.27 mm (7.00 in. ± 0.05 in.) long by thickness.

6.3 The edges shall be smooth machined surfaces without cracks, and the test specimen surface shall be free of defects or irregularities. If the test specimen has been machined to thickness, the non-machined surface shall be the test surface.

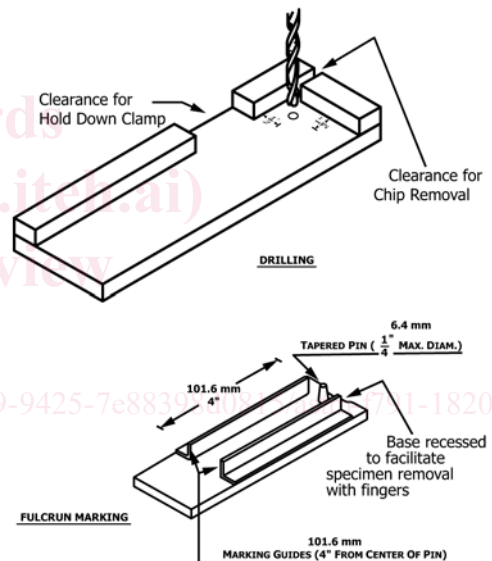

FIG. 3 Fixtures for Specimen Preparation

## 7. Preparation of Apparatus

7.1 Once the load for a particular stress is calculated, that load will be the sum of the individual weights of the weight rack, rod, lead weights, container, shot, and the radiused nut. For convenience of assembly, the weight rack pan may be stamped with the total weight of the pan, rod, and nuts as a unit. A container, such as a 1/2 pt (0.24 L) paint can with a 6.4 mm (1/4 in.) hole drilled in the center of the bottom and installed so it slides up and down on the rod, can serve as a receptacle for the lead shot (or alternative non-toxic media) to attain required weight.

## 8. Conditioning

8.1 Precondition the test specimens in accordance with one of the following procedures:

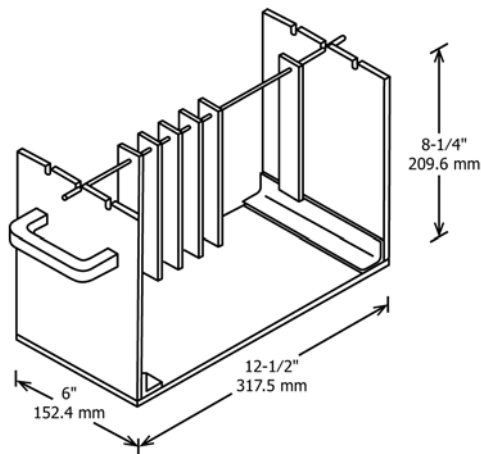

FIG. 4 Specimen Rack

application will result in an actual stress at the fulcrum which is approximately 5 % less than the expected stress, and a 38.1 mm (1.5 in.) deflection will result in an actual stress at the fulcrum which is approximately 10 % less than the expected stress.

## 10. Procedure A—Craze Stress Iteration

10.1 Place each specimen in the drill fixture and drill a 7.94 mm (0.3125 in.) diameter hole at a distance of 12.7 mm  $\pm$  1.27 mm (0.50 in.  $\pm$  0.050 in.) from one end and on the longitudinal centerline of the specimen.

10.2 Place each specimen in the marking fixture and draw a pencil line on the edge of the specimen 101.6 mm (4.0 in.) from the center of the 7.94 mm (0.3125 in.) diameter hole and perpendicular to the length of the specimen (see mark in Fig. 2).

10.3 Measure the width and thickness of each specimen to the nearest 0.03 mm (0.001 in.) at the pencil line. Handle each specimen only by its edges. Do not clean test specimens in any manner during the time period between conditioning and testing.

10.4 Insert the conditioned specimen immediately in the test fixture with the pencil mark on the specimen in line with the center of the fulcrum. Raise the weights and insert the end of the rod through the 7.94 mm (0.3125 in.) hole in the test specimen. Carefully center the load supporting nut (with a 7.94 mm (0.3125 in.) machined radius on the surface contacting the plastic) in the hole and tighten the nut. Align the specimen edges so they are exactly perpendicular to the fulcrum and slowly lower the weights until the specimen accepts the load.

10.5 Test the first specimen at 27.58 MPa (4000 psi) outer fiber stress. Apply the load for 10 min  $\pm$  0.5 min and observe to be sure no crazing has occurred. Place the 12.5 mm by 25 mm (1/2 in. by 1 in.) filter paper directly over the fulcrum in the middle of the specimen so there is a clear area along each edge to avoid inducing edge crazing. Apply the test chemical to the filter paper only. Use care so that the test material does not extend beyond this area and defeat the purpose of the test. Keep the filter paper moist with test chemical for the duration of the test, 15 min, 30 min, or any duration desired. Remove the filter paper after the test period and inspect for craze. Turn on the fluorescent lamps for inspection only to avoid undesired heating of the test specimen. Terminate the testing of that specimen.

NOTE 3—It is recommended that a control test be run with each set of craze tests. This control test is conducted exactly the same as the other craze tests, except that no chemicals shall be applied to this control specimen during the craze test. This provides a baseline and allows a determination of whether the crazing observed in the tests with the chemical applied is due to the chemical/stress combination, or is a function of stress alone.

10.6 If the first specimen is crazed, test the second specimen at 13.79 MPa (2000 psi). If the first specimen did not craze, test the second specimen at 20.68 MPa (6000 psi).

10.7 If the second specimen does not craze at 2000 psi, test the third specimen at 20.68 MPa (3000 psi). Test the fourth at a lower or higher stress depending on whether the third specimen did or did not craze. Continue this procedure in

8.1.1 *Practice D618 Procedure B*—Forty-eight hours at 50 °C (122 °F) followed by cooling to room temperature in desiccator over anhydrous calcium chloride for at least 5 h. Designate as Condition 1 and test within 15 min.

8.1.2 Two hours at 90 °C (194 °F), ambient cooled, and followed by 7 days at 23 °C  $\pm$  1.1 °C (73.5 °F  $\pm$  2 °F) and 50 %  $\pm$  5 % relative humidity. Designate as Condition 2 and test within 1 h.

8.1.3 *ARTC Method*—Sixteen hours at 14 °C (25 °F) below the average heat deflection temperature, cool at a rate not exceeding 28 °C (50 °F)/h and follow by 96 h at 23 °C  $\pm$  1.1 °C (73.5 °F  $\pm$  2 °F) and 50 %  $\pm$  5 % relative humidity. Designate as Condition 3 and test within 1 h.

8.1.4 As received, no preconditioning. Designate as Condition 4.

NOTE 1—The conditions listed above do not result in uniform moisture content for certain plastics. Moisture content reportedly has a strong effect on craze results for certain plastics. If other preconditionings are required to ensure uniform or desired moisture content, the use of these shall be reported in the test report.

## 9. Calculation of Loads

9.1 The width and thickness of each specimen shall be measured to the nearest 0.03 mm (0.001 in.). Enter this data along with the identification of the specimen in the required records.

9.2 Calculate the load to be used with each specimen in accordance with the following equation:

$$P = (S \times B \times D^2) / (6L) \quad (1)$$

where:

- $P$  = load, N (lb.),
- $S$  = maximum outer fiber stress, MPa (psi), determined by test sequence in 10.5 – 10.8, or 11.5 – 11.8,
- $L$  = length of specimen from fulcrum to center of applied load, mm (in.),
- $B$  = width of specimen, mm (in.), and
- $D$  = thickness of specimen, mm (in.).

NOTE 2—This equation is valid only for relatively small deflections. For large deflections, the dimension  $L$  shall be replaced by the actual horizontal distance from the point of load application to the fulcrum in the displaced condition. A deflection of 25.4 mm (1 in.) at the point of load

suitable increments until the critical crazing stress for specific solvent, chemical, or compound is determined to the desired accuracy.

10.8 Report the critical crazing stress as the stress midway between the stress at which crazing was and was not observed on duplicate specimens. For example: Crazing was observed at 27.58 MPa (4000 psi) and none at 24.13 MPa (3500 psi). The critical crazing stress is reported as 25.86 MPa  $\pm$  1.72 MPa (3750 psi  $\pm$  250 psi).

10.9 In the examination of the crazing, note all cracks at the edge of the specimen as “edge crazing.” Disregard this condition when ascertaining the end point unless the edge of crazing grows and extends across the entire width of the specimen.

10.10 Testing shall be at the specified temperature  $\pm$ 3 °C ( $\pm$ 5 °F).

## 11. Procedure B—Craze Stress Tracking

11.1 Place each specimen in the drill fixture and drill a 7.94 mm (0.3125 in.) diameter hole at a distance of 12.7 mm  $\pm$  1.27 mm (0.50 in.  $\pm$  0.050 in.) from one end and on the longitudinal centerline of the specimen.

11.2 Place each specimen in the marking fixture and draw a pencil line on the edge of the specimen 101.6 mm (4.0 in.) from the center of the 7.94 mm (0.3125 in.) diameter hole and perpendicular to the length of the specimen (see the mark in Fig. 2). On the side opposite the test surface, using an ink suitable for marking plastic, mark lines across the specimen surface perpendicular to the edge, from edge to edge, at 6.4 mm (0.25 in.) intervals, starting at the hole and progressing 101.6 mm (4.0 in.) to the point at which the beam will rest on the fulcrum.

11.3 Measure the width and thickness of each specimen to the nearest 0.03 mm (0.001 in.) at the pencil line. Handle each specimen only by its edges. Do not clean test specimens in any manner during the time period between conditioning and testing.

11.4 Firmly press a 3.18 mm (0.125 in.) wide ribbon of non-compressible black butyl glazing tape sealant on the test surface of the specimen along each edge to create a dam which prevents the test chemical from coming in contact with the specimen edges. Insert the conditioned specimen immediately in the test fixture with the pencil mark on the specimen in line with the center of the fulcrum. Raise the weights and insert the end of the rod through the 7.94 mm (0.3125 in.) hole in the test specimen. Carefully center the load supporting nut (with a 7.94 mm (0.3125 in.) machined radius on the surface contacting the plastic) in the hole and tighten the nut. Align the specimen edges so they are exactly perpendicular to the fulcrum and slowly lower the weights until the specimen accepts the load.

NOTE 4—It is important that the butyl sealant does not itself cause crazing of the plastic material: KPTI-303 glazing tape butyl sealant has been utilized for craze testing of acrylics and polycarbonates with no adverse effects. To evaluate crazing with butyl or other substituted dam material, conduct craze testing as described in this test method using the sealant material as the craze agent.

11.5 Test the first specimen at 27.58 MPa (4000 psi) outer fiber stress. Use the equation of 9.2 to calculate the required load. Apply the load for 10 min  $\pm$  0.5 min and observe to be sure no crazing has occurred. At the completion of the 10 minute stabilization period, activate a stop watch or timer for reference during the test. Using an eye dropper, apply test chemical to the surface of the specimen allowing it to run down the specimen between the butyl dams placed at each top surface edge of the specimens as described in 10.4. Apply chemical as needed throughout the test to maintain a wetted condition on the entire test surface of the specimen, from the fulcrum down to the point of load application. Place a pan under the point of load application to catch the chemical which drips off of the specimen. Continue the test for 15 min, 30 min, or any duration desired. During the test, monitor the specimen continuously for craze development. Record the time and location of the craze front as crazing progresses down the beam.

11.6 Calculate the craze stress for each recorded time with the following equation:

$$S = (6 \times P \times Z)/(B \times D^2) \quad (2)$$

where:

$S$  = maximum outer fiber stress, MPa (psi),

$P$  = load, N (lb),

$Z$  = the distance from the point of load application to the craze front, mm (in.),

$B$  = width of specimen, mm (in.), and

$D$  = thickness of specimen, mm (in.)

11.7 If the first specimen does not craze, test the second specimen at 41.37 MPa (6000 psi). If no crazing is observed at 41.37 MPa (6000 psi), discontinue testing.

11.8 If the first specimen breaks before the completion of the test, test the remaining specimens at a stress level below the stress at which the specimen fractured.

11.9 If the first specimen crazes below 6.895 MPa (1000 psi) (more than  $\frac{3}{4}$  of the way down the beam) conduct the remaining tests with 13.79 MPa (2000 psi) at the fulcrum.

11.10 Calculate the minimum stress at which crazing occurs. This stress shall be calculated from the equation in 11.6.

11.11 In the examination of the crazing, note all cracks at the edge of the specimen as edge crazing. Disregard this condition when ascertaining the end point unless the edge crazing grows and extends across the entire width of the specimen.

11.12 Testing shall be at the specified temperature  $\pm$  3 °C ( $\pm$  5 °F).

NOTE 5—It is recommended that a control test be run with each set of craze tests. This control test is conducted exactly the same as the other craze tests, except that no chemicals shall be applied to this control specimen during the craze test. This provides a baseline and allows a determination of whether the crazing observed in the tests with the chemical applied is due to the chemical/stress combination, or is a function of stress alone.

## 12. Report

12.1 The report shall include the following: