



Designation: ~~F2111—01a (Reapproved 2017)~~ F2111 – 22

Standard Practice for Measuring Intergranular Attack or End Grain Pitting on Metals Caused by Aircraft Chemical Processes¹

This standard is issued under the fixed designation F2111; the number immediately following the designation indicates the year of original adoption or, in the case of revision, the year of last revision. A number in parentheses indicates the year of last reapproval. A superscript epsilon (ϵ) indicates an editorial change since the last revision or reapproval.

1. Scope

1.1 This practice covers the procedures for testing and measuring intergranular attack (IGA) and end grain pitting on aircraft metals and alloys caused by maintenance or production chemicals.

1.2 The standard does not purport to address all qualification testing parameters, methods, critical testing, or criteria for aircraft production or maintenance chemical qualifications. Specific requirements and acceptance testing along with associated acceptance criteria shall be found where applicable in procurement specifications, materials specifications, appropriate process specifications, or previously agreed upon specifications.

1.3 Units—The values stated in SI units are to be regarded as the standard. The values given in parentheses are for information only.

1.4 *This standard does not purport to address all of the safety concerns, if any, associated with its use. It is the responsibility of the user of this standard to establish appropriate safety, health, and environmental practices and determine the applicability of regulatory limitations prior to use.*

1.5 *This international standard was developed in accordance with internationally recognized principles on standardization established in the Decision on Principles for the Development of International Standards, Guides and Recommendations issued by the World Trade Organization Technical Barriers to Trade (TBT) Committee.*

2. Referenced Documents

2.1 ASTM Standards:²

[E3 Guide for Preparation of Metallographic Specimens](#)

[G1 Practice for Preparing, Cleaning, and Evaluating Corrosion Test Specimens](#)

[G15 Terminology Relating to Corrosion and Corrosion Testing \(Withdrawn 2010\)](#)³

[G46 Guide for Examination and Evaluation of Pitting Corrosion](#)

2.2 ASME Standard:⁴

[B46.1 Surface Texture \(Surface Roughness, Waviness, and Lay\)](#)

¹ This practice is under the jurisdiction of ASTM Committee F07 on Aerospace and Aircraft and is the direct responsibility of Subcommittee F07.07 on Qualification Testing of Aircraft Cleaning Materials.

Current edition approved June 1, 2017/Dec. 1, 2022. Published July 2017/January 2023. Originally approved in 2001. Last previous edition approved in 2017 as F2111 – 01a (2017) (2017). DOI: 10.1520/F2111-01AR17.10.1520/F2111-22.

² For referenced ASTM standards, visit the ASTM website, www.astm.org, or contact ASTM Customer Service at service@astm.org. For *Annual Book of ASTM Standards* volume information, refer to the standard's Document Summary page on the ASTM website.

³ The last approved version of this historical standard is referenced on www.astm.org.

⁴ Available from American Society of Mechanical Engineers (ASME), ASME International Headquarters, Three Park Ave., New York, NY 10016-5990, <http://www.asme.org>.

3. Terminology

3.1 Definitions of Terms Specific to This Standard:

- 3.1.1 *longitudinal grain direction* (~~LT~~)—(*L*), *n*—the dimension parallel to the rolling or extruded direction of the extrusion in the original shape.
- 3.1.2 *long transverse* (~~LT~~)—(*LT*), *n*—the longest dimension perpendicular to the rolling or extruded direction of the extrusion in the original shape.
- 3.1.3 *pit*—*pit*, *n*—a depression or cavity with a width to depth ratio of <6 to 1.
- 3.1.4 *short transverse* (~~ST~~)—(*ST*), *n*—the shortest dimension perpendicular to the rolling or extruded direction of the extrusion in the original shape.
- 3.1.5 *surface roughness* (R_a)—*n*—filtered mean line $\mu\text{in.}$ (μm) as defined in ASME B46.1, Surface Texture.

4. Significance and Use

4.1 If not properly qualified, chemicals and chemical processes can attack metals used during aircraft maintenance and production. It is important to qualify only processes and chemical formulas that do not have any deleterious effects on aircraft metallic skins, fittings, components, and structures. This test procedure is used to detect and measure intergranular attack or pitting depth caused by aircraft maintenance chemical processes, hence, this test procedure is useful in selecting a process that will not cause intergranular attack or end grain pitting on aircraft alloys.

4.2 The purpose of this practice is to aid in the qualification or process conformance testing or production of maintenance chemicals for use on aircraft.

4.2.1 Actual aircraft processes in the production environment shall give the most representative results; however, the test results cannot be completely evaluated with respect to ambient conditions which normally vary from day to day. Additionally, when testing chemicals requiring dilutions, water quality and composition can play a role in the corrosion rates and mechanism affecting the results.

4.2.2 Some examples of maintenance and production chemicals include: organic solvents, paint strippers, cleaners, deoxidizers, water-based or semi-aqueous cleaners, or etching solutions and chemical milling solutions.

5. Apparatus and Materials

5.1 *Metallurgical Microscope*, capable of 500 \times or greater magnification with scaled filar units in microscope eyepiece.

5.2 *Metallurgical Polishing Wheel*, capable of polishing test specimen to a surface finish of ~~5- $\mu\text{in.}$~~ 5 $\mu\text{in.}$ R_a or finer.

5.3 *Noncorrosive Metallurgical Quality Polishing Media or Compound*, capable of polishing test specimens to ~~5- $\mu\text{in.}$~~ 5 $\mu\text{in.}$ R_a or finer.

6. Test Specimens

6.1 Unless otherwise specified, manufacture test specimens as follows:

6.1.1 Prepare at least one test specimen (or more, when specified by applicable process specification) from plate, sheet, extrusion, or hand forging as illustrated in Fig. 1. Use a test specimen of the same alloy, form and heat treat conditions as the parts being processed whenever possible.

6.1.2 ~~Cut out~~ Fabricate metallurgical test specimen per Fig. 1 and polish Face A to ~~0.812 μm (32 $\mu\text{in.}$)~~ 0.812 μm (32 $\mu\text{in.}$) R_a or preferably finer with polish as given in 5.3.

NOTE 1—Do not make cuts until after exposure to process cycle.

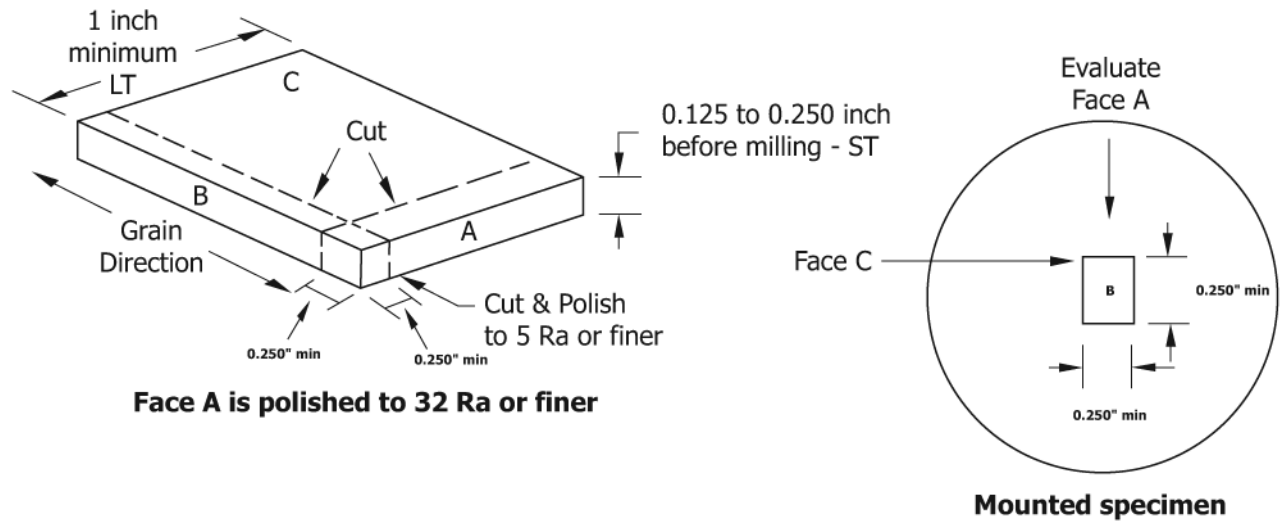

FIG. 1 Test Specimen

7. Procedure

7.1 Expose entire polished specimen through normal production or maintenance cycle. Use test temperatures and periods of time representative of the highest usage temperature and longest exposure times specimen with polished Face A to the chemical process in question. For temperature-controlled tanks, use the highest temperature associated with the chemical process. For conformance testing, process specimens with representative-like alloy parts. Process specimens through all operations including precleaning, post rinsing, and so forth, for the time necessary to remove the amount of metal specified by process or to achieve process specified cleanliness.

7.2 For chemicals normally used at room temperature for periods of less than 8 h, use $40.6 \pm 1^\circ\text{C}$ ($105 \pm 1.8^\circ\text{F}$) for an exposure time of 24 h.

7.2.1 A range of conditions shall be used over which the process is expected to operate. For example, if the process will be used from 10 to 37.8°C (50 to 100°F), data points shall be generated from 10 to 37.8°C (50 to 100°F) for completeness.

7.2 If required, clean specimen by removing corrosion products in accordance with Practice G1. An ideal procedure should remove only corrosion products and not result in the removal of any base metal.

7.3 After exposing the test specimens to the required times and temperatures, clean cross-section and mount metallurgical test specimen as illustrated in per Fig. 21 in accordance with Practice E3.

7.4 After mounting, metallurgical polish to a surface roughness of $0.127\text{ }\mu\text{m}$ ($5\text{ }\mu\text{in.}$) $0.127\text{ }\mu\text{m}$ ($5\text{ }\mu\text{in.}$) R_a or finer.

7.5 Metallurgical Evaluation of Polished Test Specimens:

7.5.1 Unless otherwise specified, observe the entire surface of Face A of the test specimen under 100 to 500 \times magnification for end grain pitting and intergranular attack.

7.5.1.1 Measure maximum width and depth of pit as illustrated in Fig. 32.

7.5.1.2 Measure maximum length of intergranular attack starting from the surface of the metal into the bulk material in the grain direction as illustrated in Fig. 32.

7.5.1.3 Guide G46 is permitted to be used as an alternate method to evaluate pitting only.

7.5.2 See Terminology G15 for definitions of terminology relating to corrosion and corrosion testing as a guidance document.