



Designation: **D4093–95 (Reapproved 2014) D4093 – 23**

Standard Test Method for Photoelastic Measurements of Birefringence and Residual Strains in Transparent or Translucent Plastic Materials¹

This standard is issued under the fixed designation D4093; the number immediately following the designation indicates the year of original adoption or, in the case of revision, the year of last revision. A number in parentheses indicates the year of last reapproval. A superscript epsilon (ϵ) indicates an editorial change since the last revision or reapproval.

INTRODUCTION

Light propagates in transparent materials at a speed, v , that is lower than its speed in vacuum, c . In isotropic unstrained materials the index of refraction, $n = c/v$, is independent of the orientation of the plane of vibration of light. Transparent materials, when strained, become optically anisotropic and the index of refraction becomes directional. The change in index of refraction is related to strains. If n_o is the refractive index of unstrained material, the three principal indices of refraction, n_i , become linear functions of strain:

$$n_i - n_o = \sum A_{ij} \epsilon_j$$

Using photoelastic techniques (initially developed to measure stresses in transparent models) strains in plastics can be assessed. In isotropic materials, two material constants, A and B , are sufficient to describe their optomechanical behavior:

$$A_{ij} = A \text{ when } i = j, \text{ and} \\ A_{ij} = B \text{ when } i \neq j.$$

When light propagates through a region (where principal strains ϵ_1 and ϵ_2 are contained in the plane perpendicular to the direction of light propagation (see Fig. 1), the incoming vibration splits into two waves vibrating in planes of ϵ_1 and ϵ_2 . The difference between the indexes of refraction $n_1 = c/v_1$ and $n_2 = c/v_2$ (or birefringence) is:

$$n_1 - n_2 = (A - B)(\epsilon_1 - \epsilon_2) = k(\epsilon_1 - \epsilon_2)$$

$$n_1 - n_2 = (A - B)(\epsilon_1 - \epsilon_2) = k(\epsilon_1 - \epsilon_2)$$

where k is a material property called the strain-optical constant. As a result of their velocity difference, the waves vibrating along the two principal planes will emerge out of phase, their relative distance, or retardation, δ , given by:

$$\delta = (n_1 - n_2)t = k(\epsilon_1 - \epsilon_2)t$$

where t is the thickness of material crossed by the light. A similar equation, relating δ to the difference of principal stresses, σ_1 and σ_2 , can be written:

$$\delta = (n_1 - n_2)t = C(\sigma_1 - \sigma_2)t$$

The objective of photoelastic investigation is to measure: (a) the azimuth, or direction of principal strains, ϵ_1 and ϵ_2 (or stresses σ_1 and σ_2), and (b) the retardation, δ , used to determine the magnitude of strains. A complete theory of photoelastic effect can be found in the abundant literature on the subject (an extensive bibliography is provided in Appendix X2).

¹ This test method is under the jurisdiction of ASTM Committee D20 on Plastics and is the direct responsibility of Subcommittee D20.10 on Mechanical Properties. Current edition approved Dec. 1, 2014/Jan. 1, 2023. Published December 2014/January 2023. Originally approved in 1982. Last previous edition approved in 2010/2014 as D4093 - 95 (2010) (2014). DOI: 10.1520/D4093-95R14.10.1520/D4093-23.

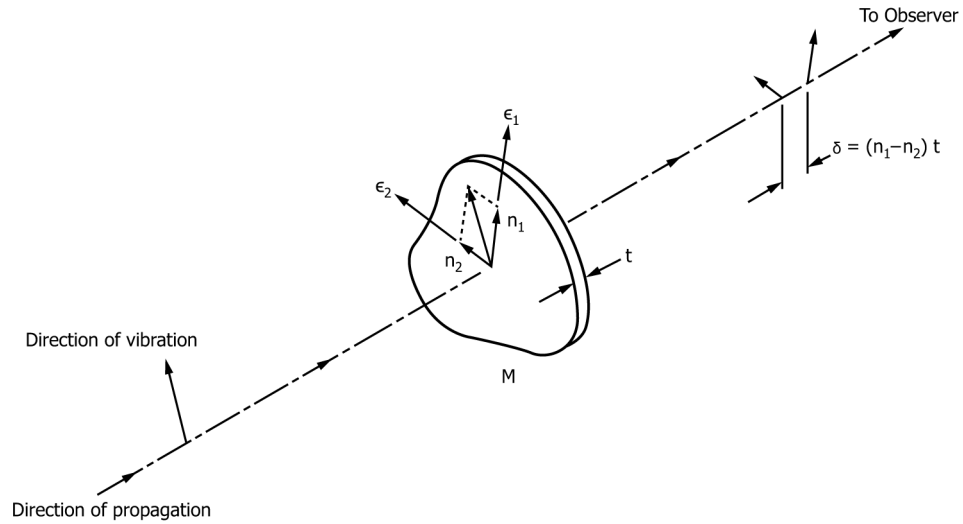

FIG. 1 Propagation of Light in a Strained Transparent Material

iTeh Standards
(<https://standards.iteh.ai>)
Document Preview

[ASTM D4093-23](#)

<https://standards.iteh.ai/catalog/standards/sist/92c49482-73d5-4231-9a9d-f7f3084a3e71/astm-d4093-23>

1. ~~Scope~~ Scope*

1.1 This quantitative test method covers measurements of direction of ~~principal~~ of principal strains, ϵ_1 and ϵ_2 , and the photoelastic retardation, δ , using a compensator, for the purpose of analyzing strains in transparent or translucent plastic materials. This test method can be used to measure birefringence and to determine the difference of principal strains or normal strains when the principal directions do not change substantially within the light path.

1.2 In addition to the method using a compensator described in this test method, other methods are in use, such as the goniometric method (using rotation of the analyzer) mostly applied for measuring small retardation, and expressing it as a fraction of a wavelength. Nonvisual methods employing spectrophotometric measurements and eliminating the human judgment factor are also possible.

1.3 Test data obtained by this test method is relevant and appropriate for use in engineering design.

1.4 The values stated in either SI units or inch-pound units are to be regarded as standard. The values stated in each system may not be exact equivalents; therefore, each system shall be used independently of the other. Combining values from the two systems may result in nonconformance with the standard.

1.5 *This standard does not purport to address all of the safety concerns, if any, associated with its use. It is the responsibility of the user of this standard to establish appropriate ~~safety~~ safety, health, and ~~health~~ environmental practices and determine the applicability of regulatory limitations prior to use.*

NOTE 1—There is no known ISO equivalent to this test method.

1.6 *This international standard was developed in accordance with internationally recognized principles on standardization established in the Decision on Principles for the Development of International Standards, Guides and Recommendations issued by the World Trade Organization Technical Barriers to Trade (TBT) Committee.*

2. Referenced Documents

2.1 ASTM Standards:²

[D618 Practice for Conditioning Plastics for Testing](#)

[D638 Test Method for Tensile Properties of Plastics](#) [ASTM D4093-23](#)

[D882 Test Method for Tensile Properties of Thin Plastic Sheet](#) [73d5-4231-9a9d-f7b084a3e71/astm-d4093-23](#)

[D883 Terminology Relating to Plastics](#)

[D4000 Classification System for Specifying Plastic Materials](#)

[E456 Terminology Relating to Quality and Statistics](#)

[E691 Practice for Conducting an Interlaboratory Study to Determine the Precision of a Test Method](#)

[E2935 Practice for Evaluating Equivalence of Two Testing Processes](#)

3. Terminology

3.1 Terms used in this standard are defined in accordance with Terminology [D883](#), unless otherwise specified. For terms relating to precision and bias and associated issues, the terms used in this standard are defined in accordance with Terminology [E456](#).

3.2 Definitions:

3.2.1 ~~compensator~~—compensator, *n*—an optical device used to measure retardation in transparent birefringent materials.

3.2.2 ~~polarizer~~—polarizer, *n*—polarizing element transmitting light vibrating in one plane only.

3.2.3 ~~quarter-wave plate~~—plate, *n*—a transparent filter providing a relative retardation of $\frac{1}{4}$ wavelength throughout the transmitting area.

3.3 Definitions of Terms Specific to This Standard:

² For referenced ASTM standards, visit the ASTM website, www.astm.org, or contact ASTM Customer Service at service@astm.org. For *Annual Book of ASTM Standards* volume information, refer to the standard's Document Summary page on the ASTM website.

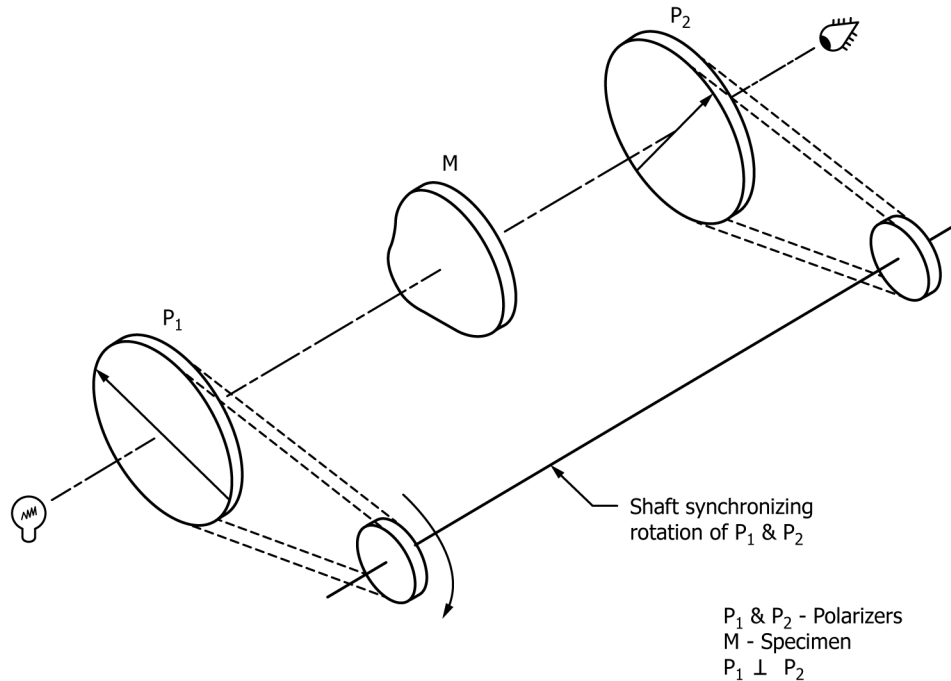

FIG. 2 Transmission Set-up of Polariscope

iTeh Standards

(<https://standards.itih.ai>)
Document Preview

3.3.1 *birefringence*—*birefringence*, n —retardation per unit thickness, δ/t .

3.3.2 *retardation*, δ —*retardation* (δ), n —distance (nm) between two wave fronts resulting from passage of light through a birefringent material. (Also called “relative retardations.”)

3.3.3 *strain*, ϵ -*strain (or deformation per unit length)*—*length*, n —could be permanent, plastic strain introduced in manufacturing process, or elastic strain related to the existing state of stress. Both types of strains will produce strain-birefringence in most polymers. Birefringence can also result from optical anisotropy due to crystalline orientation.

3.3.3.1 *Discussion*—

Both types of strains will produce strain-birefringence in most polymers. Birefringence can also result from optical anisotropy due to crystalline orientation.

3.3.4 *strain-optical constant*, k —*constant* (k), n —material property, relating the strains to changes of index of refraction (dimensionless).

$$k = (n_1 - n_2)/(\epsilon_1 - \epsilon_2)$$

3.3.5 *stress-optical constant*, C —*constant* (C), n —material property relating the stresses to change in index of refraction. C is expressed in m^2/N or Brewsters ($10^{-12} m^2/N$). C is usually temperature-dependent.

$$C = (n_1 - n_2)/(\sigma_1 - \sigma_2)$$

4. Summary of Test Method

4.1 To analyze strains photoelastically, two quantities are measured: (a) the directions of principal strains and (b) the retardation, δ , using light paths crossing the investigated material in normal or angular incidence.

4.2 The investigated specimen or sample is introduced between the polarizers (see Fig. 2 and Fig. 3). A synchronous rotation of polarizers follows until light intensity becomes zero at the observed location. The axes of the polarizers are then parallel to direction of strains, revealing these directions.

4.3 To suppress the directional sensitivity of the apparatus, the setup is changed, introducing additional filters. A calibrated

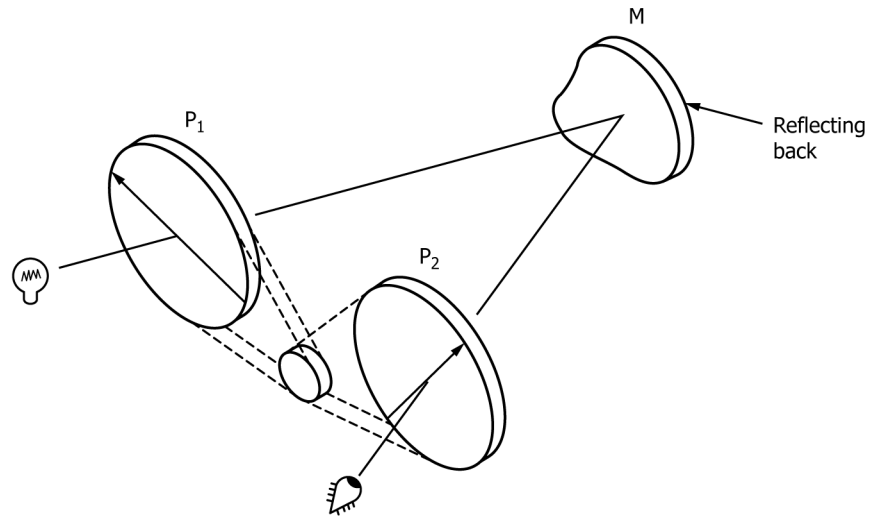

FIG. 3 Reflection Set-up of Polariscope

compensator is introduced and its setting adjusted until light intensity becomes zero at the observed location. The retardation in the calibrated compensator is then equal and opposite in sign to the retardation in the investigated specimen (see Fig. 4).

5. Significance and Use

5.1 The observation and measurement of strains in transparent or translucent materials is extensively used in various modeling techniques of experimental stress analysis.

5.2 Internal strains induced in manufacturing processes such as casting, molding, welding, extrusion, and polymer stretching can be assessed and parts exhibiting excessive strains identified. Such measurements can lead to elimination of defective parts, process improvement, control of annealing operation, etc.

5.3 When testing for physical properties, polariscopic examination of specimens is required, to eliminate those specimens exhibiting abnormal internal strain level (or defects). For example: Test Methods D638 (Note 8) and D882 (Note 11) recommend a polariscopic examination.

5.4 The birefringence of oriented polymers can be related to orientation, shrinkage, etc. The measurements of birefringence aid in characterization of these polymers.

5.5 For many materials, there may be a specification that requires the use of this test method, but with some procedural modifications that take precedence when adhering to the specification. Therefore, it is advisable to refer to that material specification before using this test method. Table 1 of Classification System D4000 lists the ASTM materials standards that currently exist.

6. Apparatus

6.1 The apparatus used to measure strains is shown schematically in Fig. 4. It consists of the following items:

6.1.1 Light Source:

6.1.1.1 *Transmitted-Light Set-Up*—An incandescent lamp or properly spaced fluorescent tubes covered with a diffuser should provide a uniformly diffused light. To ensure adequate brightness, minimum illumination required is 0.3 W/in.^2 (0.0465 W/cm^2). Maximum light source power is limited to ensure that the specimen temperature will not change more than 2°C during the test. The incandescent lamp must be selected to provide a color temperature no lower than 3150 K. There should be no visible nonuniformity, dark or bright spots on the diffuser surface, when no specimen is inserted in the apparatus.

6.1.1.2 *Reflection-Light Source*—For the reflection set-up an incandescent, reflector-equipped projection lamp is required. The

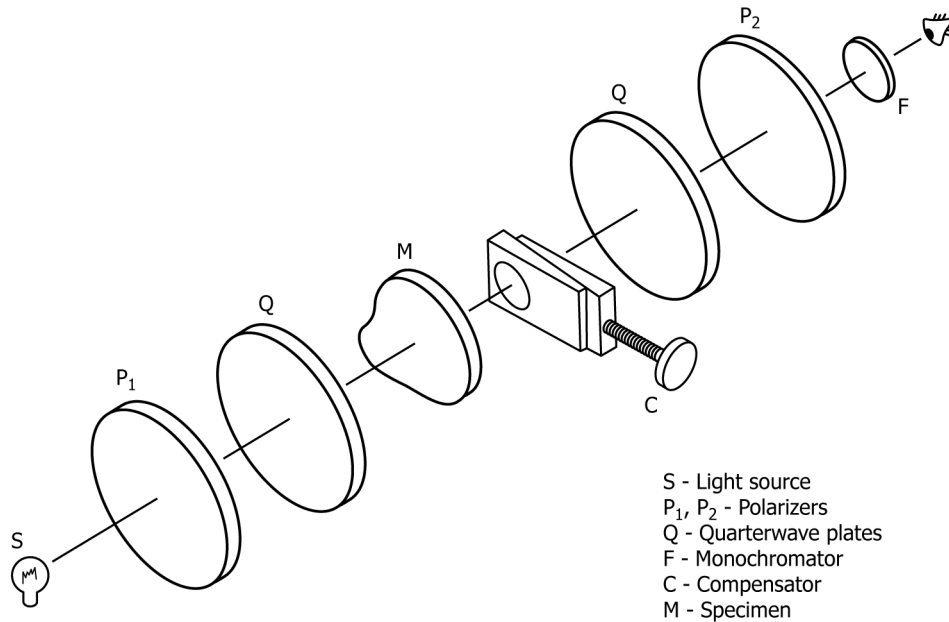

FIG. 4 Apparatus

lamp shall be equipped with proper lenses to ensure uniform illumination of the investigated object. At a distance of 2 ft (610 mm) from the lamp an area of 1 ft² (0.093 m²) should be illuminated, with no visible dark or bright spots. The lamp power should be at least 150 W.

6.1.2 *Polarizer*—The polarizing element shall be kept clean. The ratio of the transmittance of polarizers with their axes parallel, to the transmittance of the polarizers with their axes perpendicular to each other (or in crossed position), should not be less than 500. A glass-laminated construction of polarizers is recommended. The polarizers must be mechanically or electrically coupled to insure their mutually perpendicular setting while rotated together to measure directions. A graduated scale must be incorporated to indicate the common rotation of polarizers to a fixed reference mark.

6.1.3 *Quarter-Wave Plates*—Two quarter-wave plates are required in the procedure described below (see 9.2):

6.1.3.1 The retardation of each quarter-wave plate shall be 142 ± 15 nm, uniform throughout its transmission area. The difference in retardation between the two quarter-wave plates should not exceed ± 5 nm.

6.1.3.2 The quarter-wave plates will be indexed, to permit their insertion in the field of the apparatus with their axes at 45° to the polarizers direction. The two quarter-wave plates shall have their axes crossed (that is, their optical axes perpendicular to each other), thus insuring that the field remains at maximum darkness when both quarter-wave plates are inserted (see Fig. 5).

6.1.4 *Compensator*—The compensator is the essential means of measuring retardation. The following types of compensators can be used:

6.1.4.1 *Linear Compensator*³—In the linear compensator the retardation in the compensator is linearly variable along its length. A graduated scale shall be attached to the compensator body in such a manner that slippage cannot occur. The calibration characteristic of the compensator shall include the position along its length (as indicated by the scale) of the line where the retardation is zero and the number of divisions d per unit retardation (usually one wavelength). (The retardation per division is $D = \lambda/d$.) The scale density shall be sufficient to provide clear visibility for observing 1 % of the useful range of the compensator.

6.1.4.2 *Uniform Field Compensator*⁴—The uniform field compensator is usually constructed from two optical wedges moved by means of a lead screw, the amount of relative motion being linearly related to the total thickness and the retardation. The lead screw

³ Also known as “Babinet” compensator.

⁴ Also known as “Babinet-Soleil” compensator.

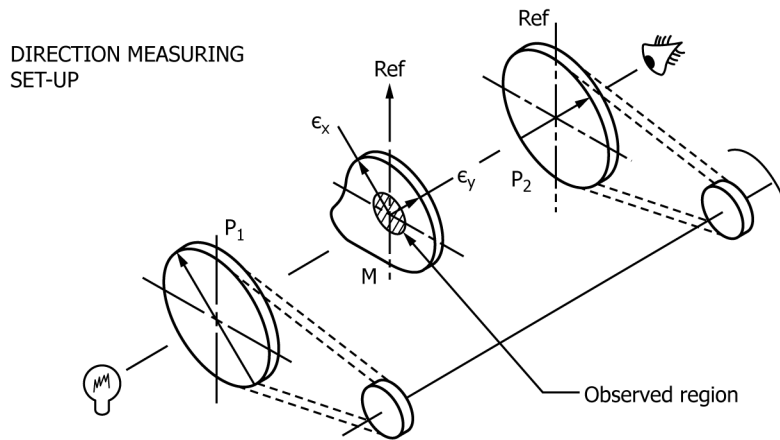

FIG. 5 Direction Measuring Set-up

motion shall be controlled by a dial drum or counter. Calibration of this compensator shall include the position, as indicated by the drum or counter, where the retardation is zero and the number of division of drum or counter d per unit of retardation. (The retardation per division is $D = \lambda/d$.)

6.1.4.3 Compensators have a limited range of measured retardation. In case the retardation in the sample exceeds the range of the compensator used, insertion of an offset retarder is needed. The offset retarder must be calibrated and positioned along the axes of the compensator, between the analyzer and the sample.

6.1.5 *Filter*—Monochromatic light is required to perform various operations in photoelasticity and some operations cannot be successfully accomplished using white light. In those instances a monochromatic light can be obtained introducing within the light path, a filter transmitting only light of the desired wave length. To best correlate with observation in white light, a narrow band-pass filter with peak transmittance at 570 ± 6 nm and a maximum transmitted band-width (at half-peak point) of 10 nm should be used.

7. Test Specimen

7.1 Sheet, film, or more generally, a constant-thickness item can be examined using a transmission set-up. For use in reflection, a reflecting surface must be provided. This can be accomplished by painting one side of the specimen with aluminum paint.⁵ Alternatively, it is possible to place the examined sheet specimen against a clean metal surface (preferably aluminum) or an aluminum-painted surface.

7.2 Examination of complex surfaces or shapes sometimes requires the use of an immersion liquid. The examined item is placed inside a tank containing a liquid selected to exhibit approximately the same index of refraction as the tested item. This technique is commonly used to examine three-dimensional shapes.

7.3 If conditioning is required, Procedure A of Practice D618 shall be used.

8. Calibration and Standardization

8.1 A periodic verification (every 6 months) is required to ensure that the apparatus is properly calibrated. The following points require verification:

8.1.1 Verification of Polariscopes:

8.1.1.1 Verify that the polarizers remain in “crossed” position. A small deviation of one of the polarizers produces an increase in the light intensity transmitted.

8.1.1.2 Verify that the quarter-wave plates are properly crossed. A small deviation of one quarter-wave plate from its “indexed” position will produce an increase in the light intensity transmitted.

⁵ Krylon aluminum aerosol can spray paint was found satisfactory.