



Designation: **F2906--22** F2906 - 23

Standard Consumer Safety Specification for Bedside Sleepers¹

This standard is issued under the fixed designation F2906; the number immediately following the designation indicates the year of original adoption or, in the case of revision, the year of last revision. A number in parentheses indicates the year of last reapproval. A superscript epsilon (ϵ) indicates an editorial change since the last revision or reapproval.

INTRODUCTION

This consumer safety specification is intended to address incidents reported by the U.S. Consumer Product Safety Commission (CPSC) relating to bedside sleepers.

In response to the incident data compiled by the CPSC, this consumer safety specification attempts to minimize the hazards associated with these products from the following: (1) occupant retention, (2) structural integrity and product assembly, and (3) deficiency of consumer education regarding product use. This consumer safety specification is intended to deal with reasonably foreseeable use and misuse of the products. This consumer safety specification does not apply to products that are blatantly misused, nor does it apply to products used by consumers in a careless manner that violate normal practice or disregard the instructions or warnings provided with the product, or both.

1. Scope

1.1 This consumer safety specification establishes performance requirements, test methods, and marking requirements to promote safe use of bedside sleepers.

1.2 This consumer safety specification is intended to minimize the risk of injury to an infant from the normal use and reasonably foreseeable misuse of a bedside sleeper.

1.3 This consumer safety performance specification covers products intended to provide sleeping space for an infant up to approximately 5 months of age (or when child begins to push up on hands and knees). These products are intended to be secured to the side of an adult bed for the purpose of having a baby sleep in close proximity to an adult.

1.4 No bedside sleeper produced after the approval date of this consumer safety specification shall, either by label or other means, indicate compliance with the specification unless it complies with all of the requirements contained herein.

1.5 This consumer safety performance specification is not intended to address incidents and injuries resulting from alteration or unreasonable abuse or misuse of the product by a child or child care provider.

1.6 The values stated in inch-pound units are to be regarded as standard. The values given in parentheses are mathematical conversions to SI units that are provided for information only and are not considered standard.

¹ This consumer safety specification is under the jurisdiction of ASTM Committee F15 on Consumer Products and is the direct responsibility of Subcommittee F15.18 on Cribs, Toddler Beds, Play Yards, Bassinets, Cradles and Baby Changing Products.

Current edition approved Oct. 1, 2022; Jan. 1, 2023. Published November 2022; January 2023. Originally approved in 2011. Last previous edition approved in 2019 as F2906 - 13 (2019); F2906 - 22. DOI: 10.1520/F2906-22.10.1520/F2906-23.

1.7 The following precautionary caveat pertains only to the test method portion, Section 6 of this consumer safety performance specification. This standard may involve the use of hazardous materials, operations and equipment. *This standard does not purport to address all of the safety concerns, if any, associated with its use. It is the responsibility of the user of this standard to establish appropriate safety, health, and environmental practices and determine the applicability of regulatory limitations prior to use.*

1.8 *This international standard was developed in accordance with internationally recognized principles on standardization established in the Decision on Principles for the Development of International Standards, Guides and Recommendations issued by the World Trade Organization Technical Barriers to Trade (TBT) Committee.*

2. Referenced Documents

2.1 ASTM Standards:²

F2085 Consumer Safety Specification for Portable Bed Rails

F2194 Consumer Safety Specification for Bassinets and Cradles

3. Terminology

3.1 Definitions:

3.1.1 *attachment system, n*—the means used to attach the bedside sleeper to the adult bed.

3.1.2 *bedside sleeper, n*—a rigid frame assembly that may be combined with a fabric or mesh assembly, or both, used to function as sides, ends, or floor or a combination thereof, and that is intended to provide a sleeping environment for infants and is secured to an adult bed.

3.1.3 *bedside sleeper accessory, n*—an elevated sleep surface that attaches to a play yard designed to convert the product into a bedside sleeper and is intended to have a horizontal sleep surface while in a rest (non-rocking) position.

3.1.4 *bedside sleeper accessory attachment components, n*—the components that provide the means of attachment for a bedside sleeper accessory to a play yard (see Fig. 1).

3.1.4.1 Discussion—

Fasteners used to permanently attach one or more components to each other such as but not limited to screws and rivets are not considered accessory attachment components.

3.1.5 *fabric, n*—any woven, knit, coated, laminated, extruded or calendered flexible material that is intended to be sewn, welded, heat sealed, or glued together as an assembly.

3.1.6 *manufacturer's recommended use position, n*—any position that is presented as a normal, allowable, or acceptable configuration for use of the product by the manufacturer in any descriptive or instructional literature.

3.1.6.1 Discussion—

This specifically excludes positions that the manufacturer shows in a like manner in its literature to be unacceptable, unsafe or not recommended.



FIG. 1 Example of Bedside Sleeper Accessory Attachment Component

² For referenced ASTM standards, visit the ASTM website, www.astm.org, or contact ASTM Customer Service at service@astm.org. For *Annual Book of ASTM Standards* volume information, refer to the standard's Document Summary page on the ASTM website.

3.1.7 *multi-mode product, n*—a unit that is designed and intended to be used in more than one mode (for example, a play yard, bassinet, changing table, hand held carrier, or bedside sleeper).

3.1.8 *occupant, n*—the infant who is placed in the bedside sleeper product in one of the manufacturer’s recommended use positions.

3.1.9 *occupant retention space, n*—space enclosed by the surfaces, for example, side walls or the floor, or both, of a bedside sleeper that contains the occupant.

3.1.10 *shell, n*—a textile cover for bedside sleeper accessory that incorporates structural elements such as tubing, permanently attached clips or hooks, or other elements which allow it to be suspended from the play yard frame.

4. Calibration and Standardization

4.1 All testing shall be conducted on a concrete floor that may be covered with 1/8 in. (3 mm) thick vinyl floor covering, unless test instructs differently.

4.2 The product shall be completely assembled in accordance with the manufacturer’s instructions.

4.3 No testing shall be conducted within 48 h of manufacture.

4.4 The product to be tested shall be at an ambient temperature of 73 °F ± 9 °F (23 °C ± 5 °C) for at least one hour before testing. All testing shall be conducted in this temperature range.

4.5 All testing required by this consumer safety specification shall be conducted on the same unit in the order presented in this specification.

5. Performance Requirements

5.1 Prior to or immediately after testing to this consumer safety specification, the bedside sleeper must be tested to Consumer Safety Specification **F2194**. Multi-mode products must also be tested to each applicable standard. When testing to Consumer Safety Specification **F2194** the unit shall be free standing, and not be secured to the test platform as dictated elsewhere in this standard.

5.1.1 The bassinet minimum side height shall be as required in Consumer Safety Specification **F2194** with the exception of a lowered side rail as permitted in **5.4**.

5.2 When the product is secured to the Test Platform 2 from 7.1.2 of Consumer Safety Specification **F2085**, per the manufacturer’s recommended method, there shall be no more than 1/2 in. (13 mm) separation from the bed measured at any point along the length of the line of contact between the product and the test platform.

5.3 Product Disengagement:

5.3.1 The bedside sleeper shall not separate from the test platform more than 1 in. (2.5 cm) at any point of attachment to the test platform when tested in accordance with **6.1.1 – 6.1.3**.

5.3.2 The bedside sleeper may separate from the test platform more than 1 in. (2.5 cm) during application of the force in **6.1.4** but shall not remain separated more than 1 in. (2.5 cm) after removal of the force.

5.4 The bedside sleeper shall have a barrier around the entire perimeter of the occupant retention space. If a bedside sleeper is equipped with a side or end portion which is lower or partially lowers by any means, the height of the side rail in the lowest position shall be no less than 4 in. (10.2 cm) when measured from the top of the uncompressed bedside sleeper mattress to the top of the lowered side rail, when the mattress support is in its highest position.

5.4.1 *Four-Inch Nest Rationale*—The center of gravity (CG) of a child lying down on his/her side is roughly the centerline of the body. Since maximum shoulder breadth for 3 to 5 month olds is 21.8 cm (8.6 in.) (Snyder, 1977), half of that is 10.9 cm (4.3 in.). Also, maximum hip breadth for the same age range is 18.2 cm (7.2 in.), half of which is 9.1 cm (3.6 in.). Assuming that the CG lies approximately along the centerline of the body and the child is laying with one side flat on the mattress, the CG will likely lie roughly between 9 cm and 11 cm above the mattress.

5.5 If a bedside sleeper is equipped with a side or end portion which partially lowers by any means, it shall remain engaged and operative after testing as follows:

5.5.1 Each single-action locking or latching device that is provided to prevent folding shall require a minimum force of 10 lbf (45 N) to activate the release mechanism when tested in accordance with 6.2.

5.5.2 Each double-action locking or latching device that is provided to prevent folding shall require two distinct and separate actions for release. There are no force requirements for double-action locking or latching devices.

5.6 The bedside sleeper shall provide a means to be secured to an adult bed. ~~The top of any lowered portion of the side rail designed to be bedside sleeper rail that is adjacent to the adult bed shall be at or below the acceptable adult bed height range specified in the instructional literature. Any fixed portion or component manufacturer's instructions except for any portion of the rail that is adjacent to the adult bed is exempt from this requirement.~~ 7.5 in. or higher when measured according to the side height requirement found in Consumer Safety Specification F2194.

5.7 *Bedside Sleeper Accessory Fabric Sided Enclosed Openings*—For bedside sleeper accessories, a completely bounded opening shall not be created that allows the complete passage of the torso probe (Fig. 2) when tested in accordance with 6.3.

5.8 *Bedside Sleeper Accessories—Missing Accessory Attachment Components:*

5.8.1 Bedside sleeper accessories that have all accessory attachment components permanently attached to the bedside sleeper accessory, or by any permanent means prohibiting their removal from the bedside sleeper accessory, are exempt from the requirements in 5.8.2.

5.8.2 Bedside sleeper accessories which require consumer assembly of accessory attachment component(s), and that can be assembled and attached to the product with any accessory attachment component(s) missing, shall meet either 5.8.2.1 or 5.8.2.2 when each accessory attachment component not permanently attached is removed.

5.8.2.1 The bedside sleeper accessory shall collapse when any part of the mattress pad contacts the bottom floor of the play yard or is not able to support the 4.0 lbf test mass when tested to 6.4.

5.8.2.2 The bedside sleeper accessory sleep surface shall tilt more than 30° when tested to 6.4.

6. Test Methods

6.1 *Product Disengagement Test Method:*

6.1.1 Assemble the bedside sleeper in the manufacturer's recommended use position(s) utilizing Test Platform 2 from Consumer Safety Specification F2085, subsection 7.1.2. The foundation of Test Platform 2 shall be placed in a common metal bed frame.

6.1.2 Apply 25 lbf (111 N) to the midpoint of a horizontal cross member closest in height to the attachment means on the bedside sleeper structure (manufacturer illustration), and in a direction most likely to dislodge the bedside sleeper from the test platform. The load shall be applied through a 2 in. by 2 in. (50 mm by 50 mm) wood block gradually over 5 s and held for 10 s. Measure the maximum separation of the product from the top of the mattress of Test Platform 2 while the force is being applied.

6.1.3 Apply 25 lbf (111 N) to one outside corner of the Bedside Sleeper structure closest to Test Platform 2 (manufacturer illustration). Apply the force to the structure perpendicular to the length of the bed within 2 in. (50 mm) of the top surface of Test Platform 2 and in a direction most likely to dislodge the bedside sleeper from the test platform. The load shall be applied through a 2 in. by 2 in. (50 mm by 50 mm) wood block gradually over 5 s and held for 10 s. Measure the separation of the product from

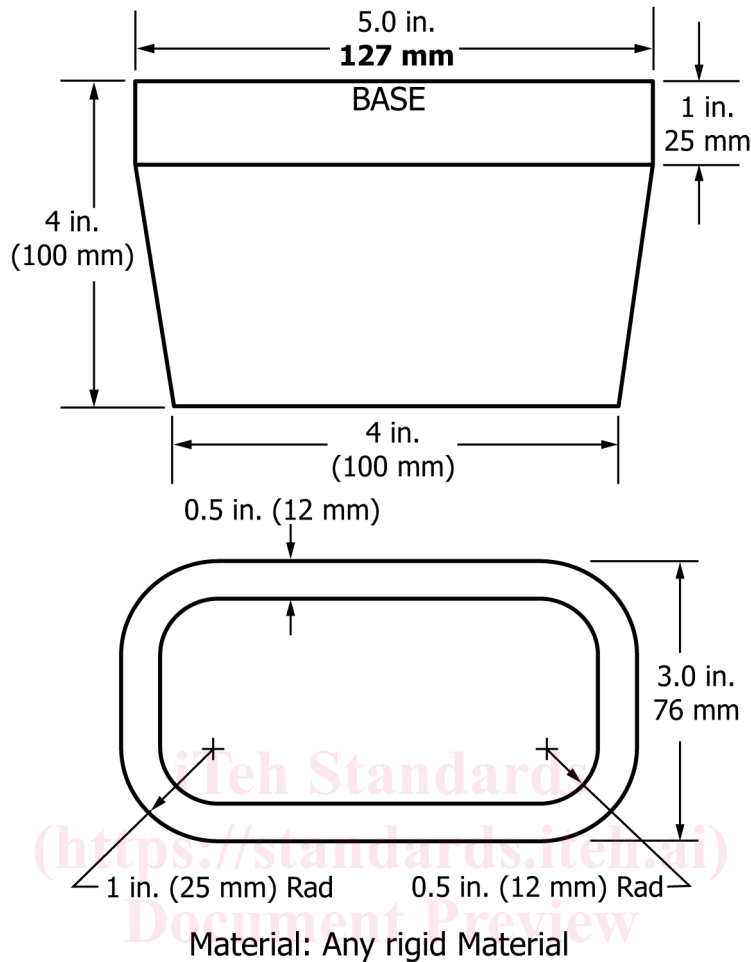

NOTE 1—The probe dimensions represent the torso diameter of a 5th percentile 0 to 2-month-old infant.

FIG. 2 Torso Probe

<https://standards.iteh.ai/catalog/standards/sist/1949ee86-408a-4da2-8312-844e8327cbee/astm-f2906-23>

Test Platform 2 at the height of the top of the mattress on the bed while the force is being applied. Repeat on the other outside corner of the product's structure closest to Test Platform 2.

6.1.4 Apply a 50 lbf (225 N) to each of the previously tested locations without adjusting the product. Apply the force over a period of 5 s. After removing the force, measure the maximum separation of the product from the Test Platform 2 at the height of the top of the mattress.

6.1.4.1 *Product Disengagement Rationale*—Tests are needed to insure product integrity and that a bedside sleeper product remains secured to the adult bed during foreseeable use and misuse of the product. The 25 lbf tests represent the maximum forces that an infant could apply to the product while located inside of the sleeping area. The 50 lbf tests represent the maximum forces that an adult may exert on the bedside sleeper product by rolling into the product while sleeping or siblings pulling on the unit while attached to an adult bed. Test forces include a safety factor of 2 times the force.

6.2 *Folding Latch Test Method*—With the product in the manufacturer's recommended use position, gradually apply a force of 10 lbf (45 N) to the locking mechanism in the direction tending to unlock it.

6.3 *Fabric Release Test Methods for Enclosed Openings:*

6.3.1 Assemble and place the bedside sleeper in the manufacturer's recommended use position. If the bedside sleeper has a non-rocking locking mechanism, place the bedside sleeper in nonrocking mode. For this test, the unit shall be free standing, and not be secured to the test platform as dictated elsewhere in this standard.