



Designation: ~~F1917 – 20<sup>ε1</sup>~~ F1917 – 23

## Standard Consumer Safety Performance Specification for Infant Bedding and Related Accessories<sup>1</sup>

This standard is issued under the fixed designation F1917; the number immediately following the designation indicates the year of original adoption or, in the case of revision, the year of last revision. A number in parentheses indicates the year of last reapproval. A superscript epsilon ( $\epsilon$ ) indicates an editorial change since the last revision or reapproval.

---

~~<sup>ε1</sup>NOTE—Subsection 9.2 was corrected editorially in November 2020.~~

---

### INTRODUCTION

This consumer safety performance specification addresses incidents associated with infant bedding and related accessories identified by the U.S. Consumer Product Safety Commission (CPSC).

In response to incident data compiled by the CPSC, this specification attempts to minimize the following hazards: entanglement, strangulation, asphyxiation. This specification is intended to cover normal use and reasonably foreseeable misuse or abuse of the product(s).

NOTE 1—This consumer safety performance specification is not intended to address incidents and injuries resulting from the interaction of other persons with children using these products or the incidents resulting from unforeseeable abuse and misuse.

This specification is written within the current state-of-the-art of infant bedding technology and will be updated whenever substantive information becomes available that necessitates additional requirements or justifies the revision of existing requirements.

### 1. Scope

1.1 This consumer safety performance specification establishes safety performance requirements, test methods, and requirements for labeling to minimize the identified hazards to children presented by infant bedding and related accessories as identified in the introduction.

1.2 *Infant bedding and related accessories* includes the following items intended for use in a nursery: fitted sheets, blankets, dust ruffles, covers and drapes for canopies, pillows, mattress covers, diaper stackers, fabric wall hangings, crib bumper/liners, and comforters.

1.3 No infant bedding or related accessory produced after the approval date of the consumer safety performance specification shall indicate, either by label or other means, compliance with this specification unless it conforms to all applicable requirements contained herein.

1.4 The values stated in inch-pound units are to be regarded as standard. The values given in parentheses are mathematical conversions to SI units that are provided for information only and are not considered standard.

---

<sup>1</sup> This consumer safety performance specification is under the jurisdiction of ASTM Committee F15 on Consumer Products and is the direct responsibility of Subcommittee F15.19 on Infant Bedding.

Current edition approved March 1, 2020. Jan. 15, 2023. Published May 2020. February 2023. Originally approved in 1999. Last previous edition approved in 2012 as F1917 – 12; F1917 – 20<sup>ε1</sup>. DOI: 10.1520/F1917-20E01-10.1520/F1917-23.

1.5 The following precautionary caveat pertains only to the test method portion, Section 7, of this specification: *This standard does not purport to address all of the safety concerns, if any, associated with its use. It is the responsibility of the user of this standard to establish appropriate safety, health, and environmental practices and determine the applicability of regulatory limitations prior to use.*

1.6 *This international standard was developed in accordance with internationally recognized principles on standardization established in the Decision on Principles for the Development of International Standards, Guides and Recommendations issued by the World Trade Organization Technical Barriers to Trade (TBT) Committee.*

## 2. Referenced Documents

### 2.1 ASTM Standards:<sup>2</sup>

[D3359 Test Methods for Rating Adhesion by Tape Test](#)

### 2.2 ANSI Standard:<sup>3</sup>

[ANSI Z535.4 Product Safety Signs and Labels](#)

[ANSI Z535.6 Product Safety Information in Manuals, Instructions, and Other Collateral Materials](#)

# iTeh Standards (<https://standards.iteh.ai>) Document Preview

[ASTM F1917-23](#)

<https://standards.iteh.ai/catalog/standards/sist/e2b9c758-85b2-4d86-ae1e-32866eff3801/astm-f1917-23>

---

<sup>2</sup> For referenced ASTM standards, visit the ASTM website, [www.astm.org](http://www.astm.org), or contact ASTM Customer Service at [service@astm.org](mailto:service@astm.org). For *Annual Book of ASTM Standards* volume information, refer to the standard's Document Summary page on the ASTM website.

<sup>3</sup> Available from American National Standards Institute (ANSI), 25 W. 43rd St., 4th Floor, New York, NY 10036, <http://www.ansi.org>.

### 2.3 Federal Regulations:<sup>4</sup>

16 CFR 1501 Method for Identifying Toys and Other Articles Intended for Use by Children under 3 Years of Age Which Present Choking, Aspiration, or Ingestion Hazards Because of Small Parts

## 3. Terminology

### 3.1 Definitions of Terms Specific to This Standard:

3.1.1 *attachment means, n*—flexible ribbons, strings, hook and loop straps, ties, and similar devices attached to a crib bumper/liner for the purpose of attaching to a crib.

3.1.2 *conspicuous, adj*—visible, when the product is in all manufacturer’s recommended use positions, to a person standing near the product at any one position around it but not necessarily visible from all positions.

3.1.3 *crib bumper/liner, n*—any product intended to be placed against any portion of the interior circumference of a crib, and that reduces or eliminates an infant’s access to the crib slats or spindles, the spaces between these components, or both.

#### 3.1.3.1 Discussion—

Such products are commonly referred to as crib bumpers, crib liners, mesh liners, bumper pads, bumper guards, and headboard panels, but do not include products intended to cover only the top horizontal rail of a crib.

3.1.4 *decorative components, n*—ornamental components attached to a crib bumper/liner for the exclusive use of being a decoration.

#### 3.1.4.1 Discussion—

Decorative components include, but are not limited to, ribbons, strings, buttons, appliqués, embellishments, etc.

3.1.5 *fabric, n*—any woven, knit, flexible material that is intended to be sewn together as an assembly.

3.1.6 *infant bedding and related accessories, n*—includes the following items intended for use in a nursery: fitted sheets, blankets, dust ruffles, covers and drapes for canopies, pillows, mattress covers, diaper stackers, fabric wall hangings, crib bumper/liner, and comforters.

3.1.7 *mesh, n*—either a woven fabric in which the warp and filling yarns are interlaced, a knitted fabric in which the wales and courses yarns are interlocked, or any other type of fabric that may be developed that provides openings therein.

<https://standards.iteh.ai/catalog/standards/sist/e2b9c758-85b2-4d86-ae1e-32866eff3801/astm-f1917-23>

3.1.8 *non-paper label, n*—any label material, such as plastic or metal, that either will not tear without the aid of tools or tears leaving a sharply-defined edge or labels made from fabric.

3.1.9 *paper label, n*—any label material (except fabric) that tears without the aid of tools and leaves a fibrous edge.

3.1.10 *supported vinyl, n*—sheet vinyl that has been laminated or bonded to a supporting material such as nylon scrim, a polyester non-woven, or other fabric material on the back or has a supporting material integrated inside the vinyl sheet such that the material is not 100 % vinyl.

3.1.11 *unsupported vinyl, n*—sheet vinyl that is 100 % vinyl and does not have any supporting material.

## 4. Calibration and Standardization

4.1 The relevant tests for an infant bedding product or related accessory can be done in any order, except where specified.

4.2 Each test may be conducted on a different sample, unless otherwise specified.

4.3 If during the course of conducting tests in accordance with this specification, a test sample sustains any permanent deformation or damage, an additional test sample shall be used for the remainder of the tests unless otherwise specified.

---

<sup>4</sup> Available from U.S. Consumer Product Safety Commission (CPSC), Washington, D.C. 20207, website: [www.cpsc.gov](http://www.cpsc.gov).

## 5. General Requirements

- 5.1 Any attachment means on a crib bumper/liner shall not exceed 9.0 in. (230 mm) when measured in accordance with 7.1.
- 5.2 Decorative components as defined in 3.1.4 shall not exceed 7 in. (180 mm) when tested in accordance with 7.1. If any decorative components can tangle to form a loop, then the perimeter of the loop shall not exceed 14 in. (360 mm) when measured in accordance with 7.1.
- 5.3 *Threads*—Use of monofilament thread in the construction of infant bedding and related accessories is prohibited.
- 5.4 A crib bumper/liner shall be capable of being secured at or near all corners and at the midpoints of the long sides of the crib. A crib bumper/liner intended for circular cribs shall be capable of being secured at intervals not exceeding 26 in. (660 mm).
- 5.5 *Labeling*—Warning labels (whether paper or non-paper) shall be permanent when tested in accordance in 7.5.
- 5.5.1 Warning statements applied directly onto the surface of the product by hot stamping, heat transfer, printing, wood burning, and so forth shall be permanent when tested in accordance with 7.6.
- 5.5.2 Non-paper labels shall not liberate small parts when tested in accordance with 7.6.
- 5.5.3 Warning labels that are attached to the fabric of crib bumper/liners with seams shall remain in contact with the fabric around the entire perimeter of the label, when the product is in all manufacturer-recommended use positions, when tested in accordance with 7.5.3.
- 5.6 Product must comply with the applicable requirements of the Consumer Product Safety Improvement Act.

## 6. Performance Requirements

### 6.1 *Unsupported Vinyl:*

- 6.1.1 Unsupported vinyl that is accessible to the infant when the product is installed in the manufacturer's recommended use position shall be 0.012 in. (0.30 mm) nominal thickness or thicker gauge. No minimum thickness is specified for supported vinyl. Any infant bedding or related accessory item composed entirely or in part of unsupported vinyl shall be tested in accordance with 7.2.
- 6.1.2 Unsupported vinyl that is not accessible to the infant when the product is installed in the manufacturer's recommended use position, such as unsupported vinyl used as a liquid barrier in a mattress cover and sandwiched between two layers of fabric are not required to be tested accordance with 7.2.

6.2 *Maximum Crib Bumper/Liner Thickness*—Each section of the crib bumper/liner shall slide through the crib bumper/liner thickness test fixture (see Fig. 1) over its entire length when tested in accordance with 7.3. The crib bumper/liner shall be tested in its pre-washed state and also after three wash/dry cycles performed according to the manufacturer's care instructions.

6.3 *Attachment Means Strength*—Following the testing specified in 7.4, an attachment means shall not fully detach from the crib bumper/liner. Partial detachment or tearing is allowed.

6.4 *Crib Bumper Firmness*—For crib bumpers with an installed thickness of 0.59 in. (15 mm) or greater, no part of the bumper shall contact the feeler arm of the firmness text fixture (see Fig. 2), when tested in accordance with 7.7.

## 7. Test Methods

7.1 *Attachment Means and Decorative Components*—Measure each attachment means or decorative component when it is extended to its maximum length under a force of 5 lbf (22 N).

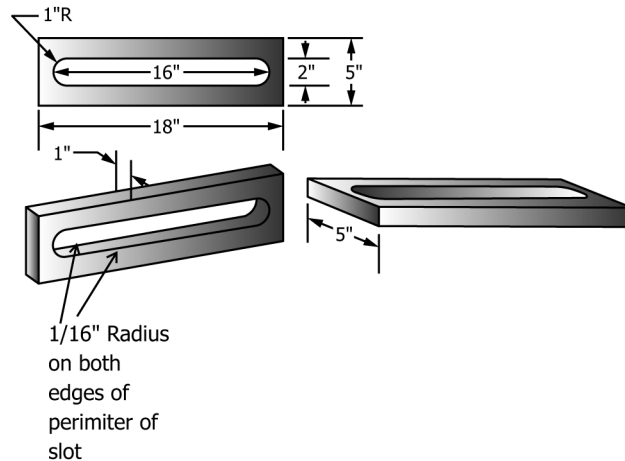

Note: Test fixture shall be fabricated from aluminum and have a smooth finish

**FIG. 1 Crib Bumper/Liner Thickness Test Fixture**

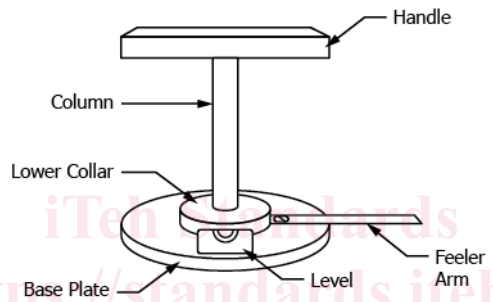

**FIG. 2 Crib Bumper/Liner Firmness Test Fixture**

7.2 *Vinyl Thickness Measurement*—Using a paper micrometer, measure the thickness at four locations, one at each end and two in a location near the middle.

ASTM F1917-23

<https://standards.iteh.ai/catalog/standards/sist/e2b9c758-85b2-4d86-ae1e-32866eff3801/astm-f1917-23>

7.3 *Crib Bumper/Liner Thickness Test*—Align the crib bumper/liner thickness test fixture so that the surface of the fixture with the opening is horizontal. Insert a crib bumper/liner end into the opening so that the crib bumper/liner end protrudes just beyond the lower surface of the test fixture and attach a 5 lb static weight to the midpoint of the protruding crib bumper/liner end. Keeping the crib bumper/liner positioned vertically, allow the weight to slowly draw the crib bumper/liner through the opening.

NOTE 2—If attachment means interfere with the crib bumper/liner sliding through the crib bumper/liner thickness test fixture, ease the attachment means through the fixture and then continue the test.

7.4 *Attachment Means Strength*—Apply a tensile force of 20 lb on the attachment means in a perpendicular direction away from the attachment point to the crib bumper/liner. The force shall be applied evenly within a period of 5 s, and maintained for an additional 10 s. The loading device shall be a self-indicating force gauge or other appropriate means having an accuracy of  $\pm 0.5$  lb ( $\pm 2$  N).

7.4.1 Attachment means that share a common attachment shall be tested together, as if they are one attachment.

NOTE 3—There is no single clamp or attachment means specified for the attachment means strength test. Any suitable means may be used to apply the force specified in 7.4, as long as it does not influence the test result.

7.5 *Permanency of Labels and Warnings:*

7.5.1 A paper label (excluding labels attached by a seam) shall be considered permanent if, during an attempt to remove it ~~with~~without the aid of tools or solvents, it cannot be removed, it tears into pieces upon removal, or such action damages the surface to which it is attached.

7.5.2 A non-paper label (excluding labels attached by a seam) shall be considered permanent if, during an attempt to remove it without the aid of tools or solvents, it cannot be removed or such action damages the surface to which it is attached.

7.5.3 A warning label attached by a seam shall be considered permanent if it does not detach when subjected to a 15 lbf (67 N) pull force applied in any direction most likely to cause failure using a 0.75 in (19 mm) diameter clamp surface. Gradually apply the force over 5 s and maintain for an additional 10 s.

*7.6 Adhesion Test for Warnings Applied Directly onto the Surface of the Product:*

7.6.1 Apply to tape test defined in Test Method B—Cross-Cut Tape Test of Test Methods **D3359**, eliminating parallel cuts.

7.6.2 Perform this test once in each different location where warnings are applied.

7.6.3 The warning statements will be considered permanent if the printing in the area tested is still legible and attached after being subjected to this test.

7.6.4 A non-paper label, during an attempt to remove it without the aid of tools or solvents, shall not fit entirely within the small parts cylinder defined in 16 CFR 1501 if it can be removed.

*7.7 Crib Bumper/Liner Firmness Test*—Select one side of the crib bumper/liner. All marks described in this section shall be made at mid-bumper/liner height. For each crib bumper/liner intended for a short side of a crib, or segments of a crib bumper/liner intended for a short side of a crib, mark two points along the bumper/liner length: one at  $\frac{1}{3}$  of the total length, and one at  $\frac{2}{3}$  of the total length. For each crib bumper/liner intended for a long side of a crib, or segments of a crib bumper/liner intended for a long side of a crib, mark three points along the bumper/liner length:  $\frac{1}{4}$ ,  $\frac{1}{2}$ , and  $\frac{3}{4}$  of the total length. There will be ten (10) marks in total for a single continuous bumper/liner intended to cover all four sides of a standard full-size rectangular crib. For each crib bumper/liner intended for a circular crib, divide the total bumper/liner length into ten (10) equal segments and mark the centroid of each segment. For crib bumper/liner no wider than 8 in. (203 mm), with the long axis intended to be installed vertically on the crib side, mark the centroid of the bumper/liner. Place the center of the firmness test fixture (**Fig. 2**) on each mark with the feeler arm oriented in a way that is most likely to contact the bumper/liner surface when the fixture is set down, such as over a plush construction. The firmness test fixture may be rotated such that the feeler arm is in any orientation that is completely over the crib bumper/liner.

*ASTM F1917-23*

*7.7.1 Test Equipment*—The crib bumper/liner firmness testing apparatus of **Fig. 2** shall be constructed with the following components:

7.7.1.1 A base plate with a diameter of 203 mm (7.99 in.), thickness of 15 mm (0.59 in.) with a bottom radius of 1 mm (0.039 in.).

7.7.1.2 A feeler arm of high-speed steel comprising a flat bar, 12 mm wide (0.47 in.), 0.51 mm to 0.76 mm (0.02 in. to 0.03 in.) thick, with square-cut ends that is positioned over a radial axis of the base plate and attached to the base plate such that the feeler arm overhangs the edge of the base plate by 40 mm (1.57 in.).

7.7.1.3 A level indicator attached to the base plate near the feeler arm, without touching, and such that it indicates level with minimum accuracy of 3.56 mm/0.3 m (0.14 in./ft) parallel to the feeler arm and does not overhang the edge of the base plate in a way that interferes with testing.

7.7.1.4 A vertical column with handle and collar attached to the center of the base plate.

7.7.1.5 Total mass of the apparatus shall be 5200 g (11.46 lb), including all components and fasteners.

7.7.1.6 Mass of the base plate shall be not less than 70 % of the total mass.

7.7.1.7 Vertical height of assembled apparatus shall not exceed 203.2 mm (8 in.) and the height of the collar shall not exceed 50.8 mm (2 in.) to minimize the bias to the base plate.

*7.7.2 Test Procedure:*

7.7.2.1 *Preconditioning of Sample*—The crib bumper/liner shall be tested in its pre-washed state and also after three wash/dry cycles performed according to the manufacturer’s care instructions. The crib bumper/liner shall be conditioned for 48 h prior to testing in an environment of  $23\text{ °C} \pm 2\text{ °C}$  ( $73.4\text{ °F} \pm 3.6\text{ °F}$ ) and a relative humidity of  $50\% \pm 5\%$ . The crib bumper/liner shall be fully assembled and dry prior to testing.

7.7.2.2 Shake the crib bumper/liner to aerate and distribute any filling materials evenly. Allow the crib bumper/liner to settle for 5 min.

7.7.2.3 Place the side to test face up on a horizontal, flat, rigid surface for testing. The crib bumper/liner may be secured to the horizontal surface using the attachment means in a manner that approximates securing the crib bumper/liner to crib rails.

7.7.2.4 Test each placement marked in 7.7 by lowering the firmness test fixture with the base plate horizontal until the fixture is supported by the crib bumper/liner. Gently adjust the orientation of the base manually if needed until it is horizontal while resting. Record any contact with the feeler arm at each placement as a failure of the firmness requirement. Repeat steps 7.7.2.2 and 7.7.2.3 if any placement is within 18 in. (457 mm) of a prior placement, or if 5 min have elapsed since completing 7.7.2.2.

7.7.2.5 Repeat firmness testing 7.7.2.1 to 7.7.2.4 until all remaining located placements have been tested or a failure has been recorded.

7.7.2.6 Repeat firmness testing on the other side of the bumper/liner. Testing the other side is not required for crib bumper/liners that cannot be reasonably installed on the other side.

## 8. Marking and Labeling

8.1 Each product and its retail package shall be marked or labeled clearly and legibly to indicate the following:

8.1.1 The name, place of business (city, state, and mailing address, including zip code), and telephone number of the manufacturer, distributor, or seller.

8.1.2 A code mark or other means that identifies the date (month and year as a minimum) of manufacture.

8.2 The marking and labeling on the product shall be permanent.

<https://standards.iteh.ai/catalog/standards/sist/e2b9c758-85b2-4d86-ae1e-32866eff3801/astm-f1917-23>

8.3 Any upholstery labeling required by law shall not be used to meet the requirements of this section.

8.4 Crib bumper/liners shall be marked or labeled clearly and legibly to identify which segments of the bumper/liner are intended for the short and long sides of the crib, unless the bumper/liner is intended for a circular crib or is less than 28 in. in length, not including attachment means.

8.5 *Warning Design for Product:*

8.5.1 The warnings shall be easy to read and understand and be in the English language at a minimum.

8.5.2 Any marking or labeling provided in addition to those required by this section shall not contradict or confuse the meaning of the required information, or be otherwise misleading to the consumer.

8.5.3 The warnings shall be conspicuous and permanent.

8.5.4 The warnings shall conform to ANSI Z535.4 – 2011, American National Standard for Product Safety Signs and Labels, sections 6.1-6.4, 7.2-7.6.3, and 8.1, with the following changes:

8.5.4.1 In sections 6.2.2, 7.3, 7.5, and 8.1.2, replace “should” with “shall”.

8.5.4.2 In sections 7.6.3, replace “should (when feasible)” with “shall”.

8.5.4.3 Strike the word “safety” when used immediately before a color (for example, replace “safety white” with “white”).