



Designation: ~~D6194—18~~ D6194 – 23

## Standard Test Method for Glow-Wire Ignition of Materials<sup>1</sup>

This standard is issued under the fixed designation D6194; the number immediately following the designation indicates the year of original adoption or, in the case of revision, the year of last revision. A number in parentheses indicates the year of last reapproval. A superscript epsilon ( $\epsilon$ ) indicates an editorial change since the last revision or reapproval.

### 1. Scope\*

1.1 This test method covers the minimum temperature required to ignite insulating materials using a glowing heat source. In a preliminary fashion, this test method differentiates between the susceptibilities of different materials with respect to their resistance to ignition due to an electrically-heated source.

1.2 This test method applies to molded or sheet materials available in thicknesses ranging from  $0.250.25$  mm to 6.4 mm.

1.3 This test method is not valid for determining the ignition behavior of complete electrotechnical equipment, since the design of the electrotechnical product influences the heat transfer between adjacent parts.

1.4 This test method measures and describes the response of materials, products, or assemblies to heat and flame under controlled conditions, but does not by itself incorporate all factors required for fire hazard or fire risk assessment of the materials, products, or assemblies under actual fire conditions.

1.5 The values stated in SI units are to be regarded as standard. No other units of measurement are included in this standard. (See [IEEE/ASTM SI-10](#) for further details.) For specific precautionary statements, see Section 9.

1.6 *This standard does not purport to address all of the safety concerns, if any, associated with its use. It is the responsibility of the user of this standard to establish appropriate safety, health, and environmental practices and determine the applicability of regulatory limitations prior to use.* For specific precautionary statements, see Section 9.

1.7 *Fire testing is inherently hazardous. Adequate safeguards for personnel and property shall be employed in conducting these tests.*

NOTE 1—Although this test method and IEC 60695-2-12 differ in approach and in detail, data obtained to determine the glow-wire flammability index (GWFI) using either test method are technically similar. Although this test method and IEC 60695-2-13 differ in approach and in detail, data obtained using either are technically equivalent. to determine the glow-wire ignition temperature (GWIT) using either test method are technically similar.

1.8 *This international standard was developed in accordance with internationally recognized principles on standardization established in the Decision on Principles for the Development of International Standards, Guides and Recommendations issued by the World Trade Organization Technical Barriers to Trade (TBT) Committee.*

<sup>1</sup> This test method is under the jurisdiction of ASTM Committee D09 on Electrical and Electronic Insulating Materials and is the direct responsibility of Subcommittee D09.17 on Fire and Thermal Properties.

Current edition approved Nov. 1, 2018Feb. 1, 2023. Published December 2018February 2023. Originally approved in 1997. Last previous edition approved in 20142018 as ~~D6194—14~~D6194 – 18. DOI: ~~10.1520/D6194-18~~10.1520/D6194-23.

\*A Summary of Changes section appears at the end of this standard

## 2. Referenced Documents

### 2.1 ASTM Standards:<sup>2</sup>

**D1711** Terminology Relating to Electrical Insulation

**E176** Terminology of Fire Standards

**E220** Test Method for Calibration of Thermocouples By Comparison Techniques

**E230/E230M** Specification for Temperature-Electromotive Force (emf) Tables for Standardized Thermocouples

**IEEE/ASTM SI-10** International System of Units (SI), The Modernized Metric System

### 2.2 IEC Standard:

**IEC 60695-4** Fire Hazard Testing—Part 4: Terminology Concerning Fire Tests for Electrotechnical Products<sup>3</sup>

**IEC 60695-2-12** Fire Hazard Testing—Part 2-12: Glowing/Hot-Wire Based Test Methods—Glow-Wire Flammability (GWFI) Test Method for Materials<sup>3</sup>

**IEC 60695-2-13** Fire Hazard Testing—Section 20: Glowing/Hot-Wire Based Test Methods—Glow-Wire Coil Ignitability Ignition Temperature (GWIT) Test Method for Materials<sup>3</sup>

### 2.3 ISO Standard:<sup>4</sup>

**ISO 13943** Fire Safety—Vocabulary

## 3. Terminology

### 3.1 Definitions:

3.1.1 Use Terminology **E176**, ISO 13943, and IEC 60695-4 for definitions of terms used in this test method and associated with fire issues. Where differences exist in definitions, those contained in Terminology **E176** shall be used. Use Terminology **D1711** for definitions of terms used in this test method and associated with electrical insulation materials. The 2017 edition of ISO 13943 has incorporated many of the relevant terms of IEC 60695-4.

3.1.2 *ignition, n*—the initiation of combustion (Terminology **E176**).

#### 3.1.2.1 Discussion—

The combustion may be evidenced by glow, flame, detonation, or explosion. The combustion may be sustained or transient (Terminology **E176**).

### 3.2 Definitions of Terms Specific to This Standard:

3.2.1 *glow-wire, n*—a wire of specified dimensions that can be controllably heated electrically to determine ignitability of a material.

<https://standards.iteh.ai/catalog/standards/sist/d6851a2f-ce5e-4205-9f55-75368e4779fc/astm-d6194-23>

3.2.2 *glow-wire flammability index (GWFI), n*—the highest test temperature, during three subsequent tests for a test specimen of a given thickness, at which one of the following conditions are fulfilled: *a*) flames or glowing of the test specimen extinguish within 30 s after removal of the glow-wire and there is no ignition of the wrapping tissue placed underneath the test specimen; *b*) there is no ignition of the test specimen.

3.2.3 *glow-wire ignition temperature (GWIT), n*—the temperature which is  $25^{\circ}\text{C}$  ( $30^{\circ}\text{C}$ )  $25^{\circ}\text{C}$  ( $30^{\circ}\text{C}$ ) between 900 and  $960^{\circ}\text{C}$  ( $960^{\circ}\text{C}$ ) higher than the GWFI.

## 4. Summary of Test Method

4.1 In this test method, a standardized test specimen (either square or round), is supported vertically and is exposed to electrical heating from a glow-wire set at pre-determined temperatures. The minimum temperature for glow-wire ignition is assessed through testing at incremental temperatures.

4.2 In this test method, ignition is deemed to have taken place when the first of the following occurs: sustained flaming on the test specimen surface for over 5 s, or falling particles causing the appearance of flames on a tissue paper placed underneath the test specimen.

<sup>2</sup> For referenced ASTM standards, visit the ASTM website, [www.astm.org](http://www.astm.org), or contact ASTM Customer Service at [service@astm.org](mailto:service@astm.org). For *Annual Book of ASTM Standards* volume information, refer to the standard's Document Summary page on the ASTM website.

<sup>3</sup> Available from International Electrotechnical Commission (IEC), 3 Rue de Varembe, Case postale 131, CH-1211, Geneva 20, Switzerland, <http://www.iec.ch>.

<sup>4</sup> Use undyed, soft, strong, lightweight tissue paper weighing between  $1212\text{ g/m}^2$  and  $30\text{ g/m}^2$ .

5. Significance and Use

5.1 During operation of electrical equipment, including wires, resistors, and other conductors, it is possible for overheating to occur under certain conditions of operation, or when malfunctions occur. When this happens, a possible result is ignition of the adjacent insulation material.

5.2 This test method assesses the susceptibility of electrical insulating materials to ignition as a result of exposure to a glowing wire.

5.3 This test method determines the minimum temperature required to ignite a material by the effect of a glowing heat source, under the specified conditions of test.

5.4 This method is suitable, subject to the appropriate limitations of an expected precision of  $\pm 15\%$ , to categorize materials.

5.5 In this procedure, the specimens are subjected to one or more specific sets of laboratory conditions. If different test conditions are substituted or the end-use conditions are changed, it is not always possible by or from this test to predict changes in the fire-test-response characteristics measured. Therefore, the results are valid only for the fire test exposure conditions described in this procedure.

6. Apparatus

6.1 *Glow-wire*—The glow-wire shall be a Nichrome (Nickel-Chrome) wire that is iron free, with the following nominal properties: a wire composition of 20 % chromium-80 % nickel, a diameter of 4 mm, and it shall be formed to the dimensions shown in Fig. 1, which describes the glow wire and its positioning.

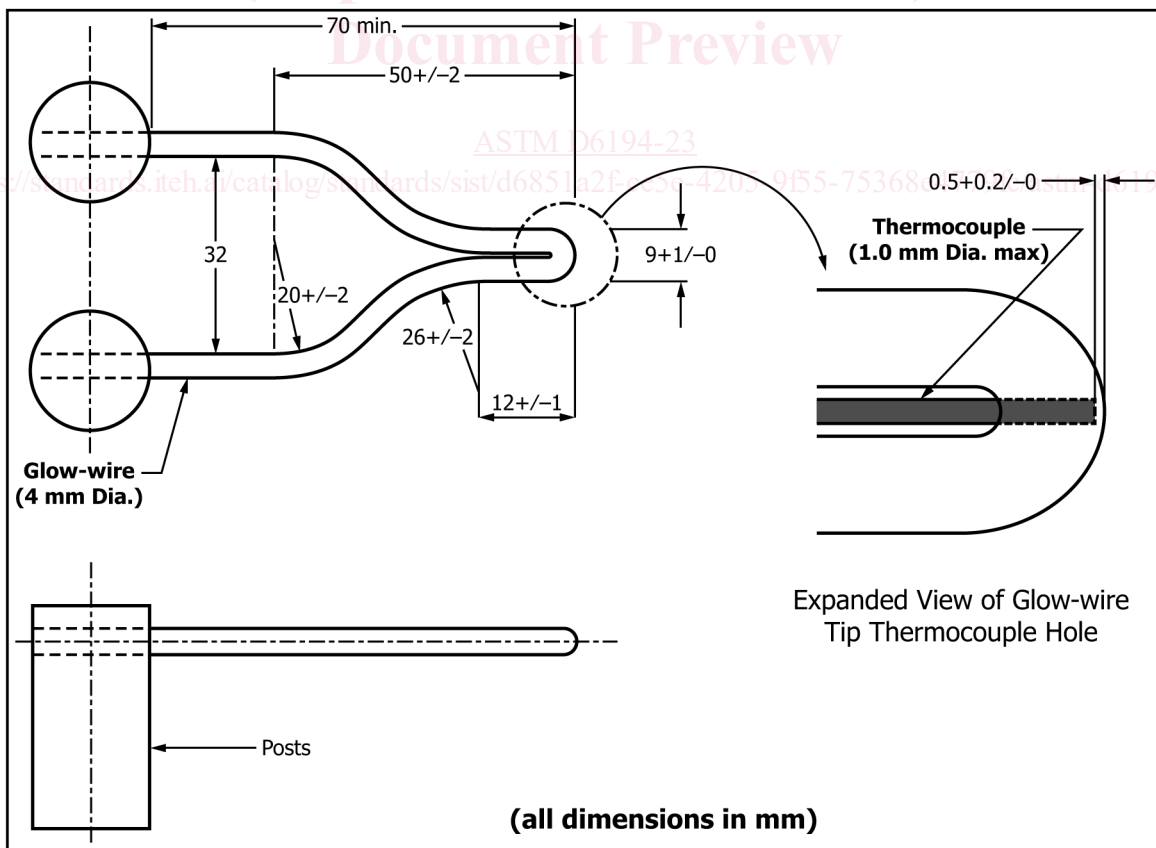

NOTE 1—All dimensions in millimetres.  
**FIG. 1 Glow-Wire and Positioning of Thermocouple**

6.2 *Thermocouple*—Use Type K sheathed fine-wire thermocouple, having an overall diameter of 1.0 mm max, and wires suitable for continuous operation at temperatures up to  $960^{\circ}\text{C}$ ;  $960^{\circ}\text{C}$ , with the welded point located inside the sheath, for measuring the temperature of the glow-wire. Examples of suitable wire compositions are Nickel-Chromium (NiCr) and Nickel-Aluminum (NiAl).

6.2.1 Construct the thermocouple sheath of a metal that will allow the thermocouple to perform its function in air at sheath temperatures of at least  $1050^{\circ}\text{C}$ ;  $1050^{\circ}\text{C}$ . Arrange the thermocouple in a pocket hole, drilled in the tip of the glow-wire, as shown in Fig. 1. Maintain the thermal contact between the walls of the bored hole in the glow-wire by pinning the sheathed thermocouple in place. Ensure that the thermocouple follows the movement of the tip of the glow-wire resulting from elongation caused by thermal heating.

6.3 *Temperature Indicator*—Use a temperature indicator for Type K thermocouples capable of reading up to  $1000^{\circ}\text{C}$ ;  $1000^{\circ}\text{C}$ . Calibrate the combination thermocouple and temperature indicator in accordance with the general procedures outlined in Test Method E220. The initial calibration tolerance is defined in the tables of Specification and Temperature-Electromotive Force (EMF) Tables E230/E230M.

6.4 *Supply Circuit*—The supply circuit shall be capable of supplying up to 150 A at 2.1 V, with smooth continuous adjustment of voltage to provide the required current as needed to maintain the desired glow-wire tip temperature.

6.5 *Test Fixture*—As shown in Fig. 2, the test fixture shall be capable of holding the glow-wire in a horizontal plane and moving it against the vertical test specimen, maintaining a force of  $1.0\text{ N} \pm 0.2\text{ N}$  over a distance of at least 7 mm.

6.5.1 Use a weight of  $100\text{ g} \pm 20\text{ g}$  to provide the required force.

6.6 *Indicator Board*—Use as indicator a flat pine wood board with a smooth finish, approximately 10 mm thick, and in close contact with a single layer of tissue paper,<sup>4</sup> located at a distance of  $200\text{ mm} \pm 5\text{ mm}$  below the glow-wire tip.

6.7 *Test Chamber*—Use as a test chamber a closed draft-free chamber that permits observation of the specimen and has a volume

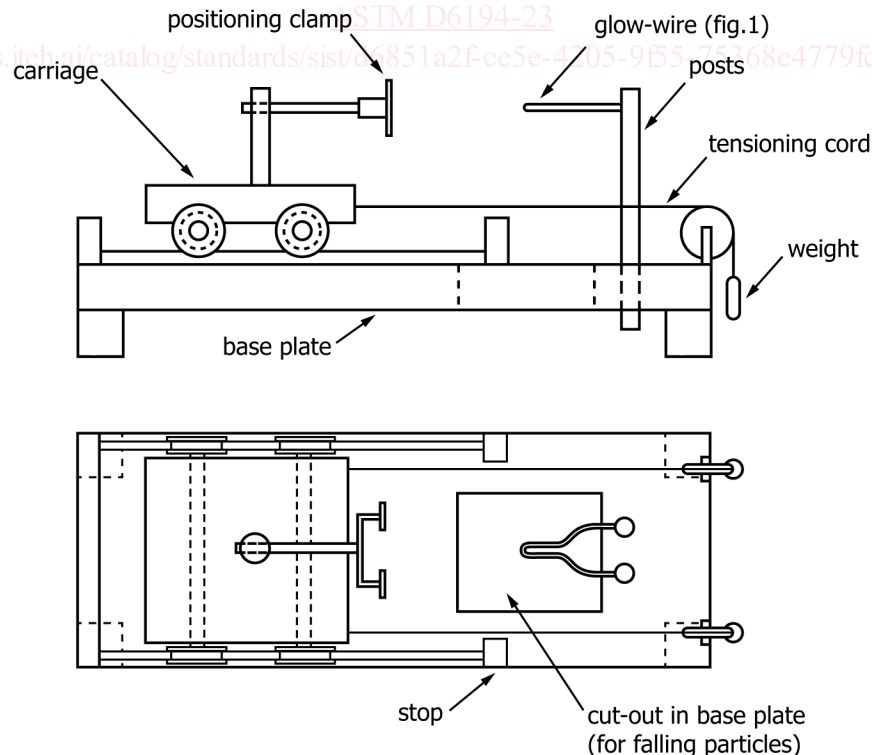

FIG. 2 Test Apparatus (Example)