



Standard Terminology for Surgical Suture Needles¹

This standard is issued under the fixed designation F1840; the number immediately following the designation indicates the year of original adoption or, in the case of revision, the year of last revision. A number in parentheses indicates the year of last reapproval. A superscript epsilon (ϵ) indicates an editorial change since the last revision or reapproval.

1. Scope

1.1 This terminology covers general definitions for surgical needles.

1.2 *This international standard was developed in accordance with internationally recognized principles on standardization established in the Decision on Principles for the Development of International Standards, Guides and Recommendations issued by the World Trade Organization Technical Barriers to Trade (TBT) Committee.*

2. Terminology

2.1 *Definitions of Terms Specific to the Instrument* (see Fig. 1):

attachment area, n —portion of the needle where the attachment of the suture takes place. For example, eyed, drilled, and channel.

body, n —central portion of the needle intended to be grasped by the needle holder.

chord length, n —the straight line distance between the two ends of a curved needle.

curvature, n —the shape of the needle viewed in profile. Some common shapes include, but are not limited to: straight, $\frac{1}{2}$ curve or “ski,” $\frac{1}{8}$ circle, $\frac{1}{4}$ circle, $\frac{3}{8}$ circle, $\frac{1}{2}$ circle, $\frac{5}{8}$ circle, and compound curvature (see Fig. 2).

cutting edge, n —cutting edges are made of various geometric shapes, that is, triangular, diamond, and hexagonal. The various edges may be sharpened by the manufacturer depending on the user performance.

needle length, n —the distance measured along the needle curvature from end to end.

¹ This terminology is under the jurisdiction of ASTM Committee F04 on Medical and Surgical Materials and Devices and is the direct responsibility of Subcommittee F04.33 on Medical/Surgical Instruments.

Current edition approved Feb. 1, 2023. Published February 2023. Originally approved in 1997. Last previous edition approved in 2016 as F1840 – 10 (2016). DOI: 10.1520/F1840-10R23.

needle radius, n —the radius of the uniformly curved portion or portions of the needle measured from the centerline of the needle body.

needle wire diameter, n —the gage or thickness of the needle wire, measured at a location between the needle body and the attachment area, where either no or minimal work has taken place.

point, n —portion of the needle intended to initiate tissue penetration.

point configuration, n —the shape of the point. Some common point configurations include, but are not limited to (see Fig. 3): taper, trocar, blunt, spatulated, conventional cutting edge, reverse cutting edge, cutting taper, and side cutting needle.

swage, n —the term used to describe any attachment method that uses mechanical force to crimp the end of the needle and firmly hold the suture in place.

2.2 *Definitions of Terms Specific to Mechanical Properties of a Surgical Needle:*

finish, n —final surface visual appearance classified as follows:
bright or mirror finish, n —highly reflective surface.

satın, matte, or black finish, n —reduced reflective surface (as compared to bright or mirror finish) varying from a dull appearance to a blackened surface.

maximum bend moment—the greatest moment applied to a needle during a bend test.

needle ductility—a measure of the amount of plastic bending a needle can withstand.

yield bend angle—the angle at which the yield bend moment occurs.

yield bend moment—the amount of moment required to initiate plastic deformation during a bend test.

3. Keywords

3.1 needle; stainless steel—surgical applications; surgical; suture needle

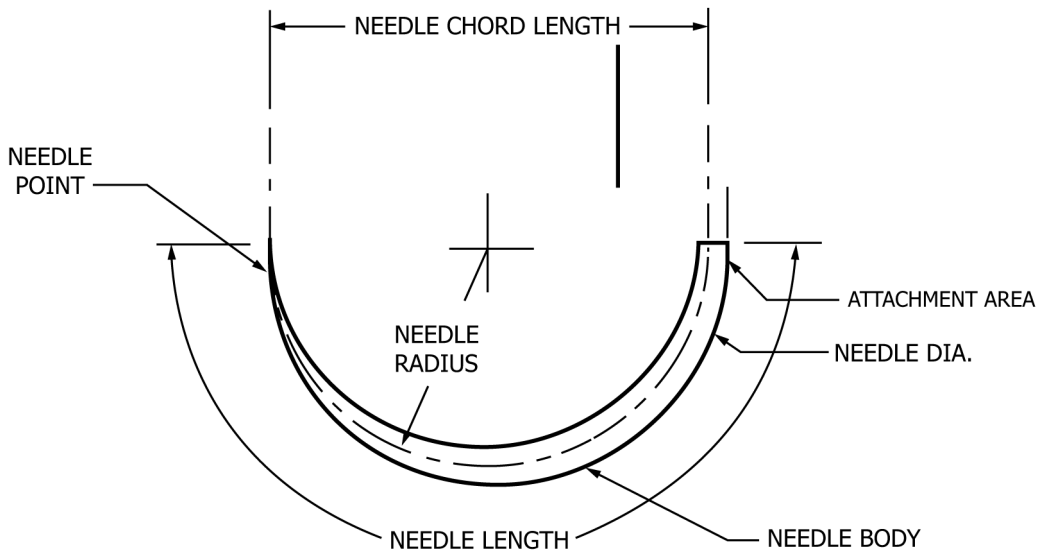
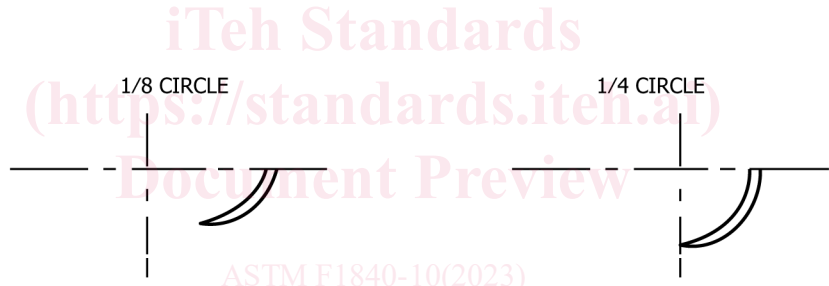

FIG. 1 Schematic of a Surgical Needle



ASTM F1840-10(2023)

<https://standards.iteh.ai/catalog/standards/sist/86e908c1-1f4a-451b-ab69-617d96a9b840/astm-f1840-102023>

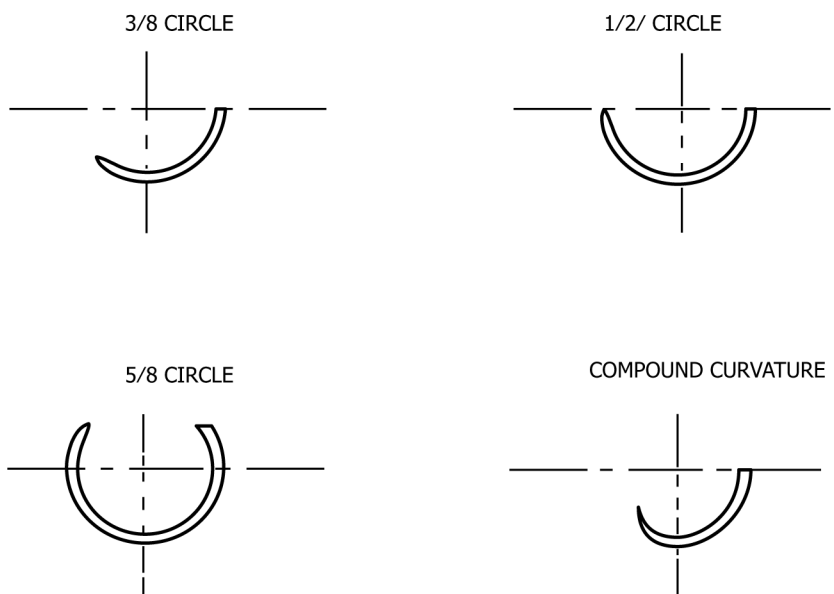

FIG. 2 Typical Curvatures