



Designation: **B964 – 16 B964 – 23**

Standard Test Methods for Flow Rate of Metal Powders Using the Carney Funnel¹

This standard is issued under the fixed designation B964; the number immediately following the designation indicates the year of original adoption or, in the case of revision, the year of last revision. A number in parentheses indicates the year of last reapproval. A superscript epsilon (ϵ) indicates an editorial change since the last revision or reapproval.

1. Scope*

1.1 These test methods cover the determination of a flow rate, by use of the Carney funnel, of metal powders and powder mixtures that do not readily flow through the Hall funnel of Test Method **B213**.

1.2 This is a non-destructive quantitative test performed in the laboratory.

1.3 With the exception of the values for density and the mass used to determine density, for which the use of gram per cubic centimetre (g/cm^3) and gram (g) units is the longstanding industry practice, the values in inch-pound units are to be regarded as standard. The values given in parentheses are mathematical conversions to SI units that are provided for information only, and are not considered standard.

1.4 *This standard does not purport to address all of the safety concerns, if any, associated with its use. It is the responsibility of the user of this standard to establish appropriate safety and health, safety, health, and environmental practices and determine the applicability of regulatory limitations prior to use.*

1.5 *This international standard was developed in accordance with internationally recognized principles on standardization established in the Decision on Principles for the Development of International Standards, Guides and Recommendations issued by the World Trade Organization Technical Barriers to Trade (TBT) Committee.*

2. Referenced Documents

2.1 *ASTM Standards:*²

B213 Test Methods for Flow Rate of Metal Powders Using the Hall Flowmeter Funnel

B215 Practices for Sampling Metal Powders

B243 Terminology of Powder Metallurgy

B855 Test Method for Volumetric Flow Rate of Metal Powders Using the Arnold Meter and Hall Flowmeter Funnel

3. Terminology

3.1 Definitions of powder metallurgy (PM) terms can be found in Terminology **B243**.

3.2 *Definitions of Terms Specific to This Standard:*

3.2.1 *Carney flow rate (FR_C), n*—the time required for a metal powder sample of specified mass to flow through the orifice in a Carney funnel according to a specified procedure.

¹ These test methods are under the jurisdiction of ASTM Committee **B09** on Metal Powders and Metal Powder Products and are the direct responsibility of Subcommittee **B09.02** on Base Metal Powders.

Current edition approved June 1, 2016; Feb. 1, 2023. Published June 2016; February 2023. Originally approved in 2009. Last previous edition approved in 2009 as **B964B964 – 16, 09**; DOI: 10.1520/B0964-16.10.1520/B0964-23.

² For referenced ASTM standards, visit the ASTM website, www.astm.org, or contact ASTM Customer Service at service@astm.org. For *Annual Book of ASTM Standards* volume information, refer to the standard's Document Summary page on the ASTM website.

*A Summary of Changes section appears at the end of this standard

3.3 Additional descriptive information is available in the Related Materials section of Vol 02.05 of the Annual Book of ASTM Standards.

4. Summary of Test Methods

4.1 A weighed mass of metal powder is timed as it flows through the orifice of a Carney funnel.

5. Significance and Use

5.1 The rate and uniformity of die cavity filling are related to flow properties, which thus influence production rates and uniformity of compacted parts.

5.2 The ability of a powder to flow is a function of interparticle friction. As interparticle friction increases, flow is slowed. Some powders, often fine powders and lubricated powder mixtures, may not flow through the Hall funnel of Test Method B213. Nevertheless, if a larger orifice is provided, such as in the Carney funnel, a meaningful flow rate may be determined, providing specific information for certain applications.

5.3 Test Method B213, using the Hall funnel, is the preferred method for determining the flowability of metal powders. The Carney funnel of these test methods should only be used when a powder will not flow through the Hall funnel. These test methods may also be used for comparison of several powders when some flow through the Hall funnel and some do not.

5.4 Humidity and moisture content influence flow rate. Wet or moist powders may not flow through either the Hall or the Carney funnel.

5.5 These test methods are based on flow of a specific mass of powder. If flow of a specific volume of powder is preferred, Test Method B855 may be used for powders that flow readily through the Hall funnel.

5.6 These test methods may be part of the purchase agreement between powder suppliers and powder metallurgy (PM) part producers, or it can be an internal quality control test by either the supplier or the end user.

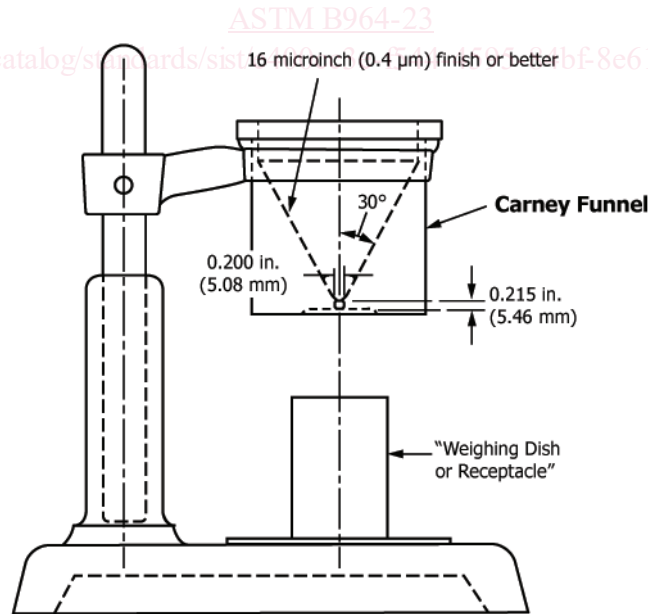

FIG. 1 Carney Funnel and Stand

6. Apparatus

6.1 *Carney Powder Flowmeter Funnel*³—A calibrated flowmeter funnel (Fig. 1) having an orifice of 0.200 ± 0.005 in. (5.08 ± 0.13 mm) 0.200 in. (5.08 mm) in diameter.

6.1.1 The funnel shall be made of a non-magnetic, corrosion-resistant metallic material having sufficient thickness and hardness to withstand distortion and excessive wear.

6.1.2 The dimensions shown for the flowmeter funnel (Fig. 1), including the orifice, are not to be considered controlling factors. Calibration with the stainless steel reference powder (6.2), as specified in Section 9, determines the working flow rate of the funnel.

6.2 *316L Stainless Steel Reference Powder*³—A certified stainless steel powder used to calibrate the flowmeter funnel.

6.3 *Stand*³—A stand (Fig. 1) to support the powder flowmeter funnel.

6.4 *Base*—A level, vibration-free base to support the powder flowmeter stand.

6.5 *Timing Device*—A stopwatch or other suitable timing device capable of measuring to the nearest 0.1 s.

6.6 *Balance*—Having a capacity of at least 250 g and a sensitivity of 0.01 g.

6.7 *Weighing Dish*—An ordinary laboratory weighing dish (pan), capable of containing the full mass of tested powder, and preferably made of metal to avoid powder sticking to the dish via electrostatic charges.

7. Sampling

7.1 A test sample of powder sufficient to run the desired number of flow tests shall be obtained in accordance with Practices B215.

7.2 Individual test portions, each of approximately the required mass, shall be obtained from the test sample in accordance with Practices B215.

8. Preparation of Apparatus

8.1 Clean the funnel with a clean, dry paper towel.

8.2 Clean the funnel orifice with a clean dry pipe cleaner.

9. Calibration of Apparatus

~~9.1 Plans are under way for developing a reference material that can be used to calibrate the Carney powder flowmeter funnel, similar to the material used for calibration of the Hall powder flowmeter funnel in Test Method B213.~~

~~9.1 In the absence of such a reference material, it is recommended that the dimensions of the Carney~~ A new powder flowmeter funnel be checked periodically, at least every six months. If the dimensions are not supplied as calibrated using a certified 316L stainless steel reference powder (see 6.2) longer within the specified tolerances, replace the flowmeter funnel.) as follows (an older flowmeter funnel shall be calibrated in the same manner):

9.1.1 Heat an open glass jar that contains the calibration powder in a drying oven at a temperature of 215 °F to 225 °F (102 °C to 107 °C) for 1 h.

³ The sole source of supply of the flowmeter funnel, stainless steel reference powder, and stand known to the committee at this time is ~~ACu Powder International, LLC, 901 Lehigh Avenue, Union, NJ 07083; Kymera International, 2601 Weck Drive, Research Triangle Park, NC 27709.~~ If you are aware of alternative suppliers, please provide this information to ASTM International Headquarters. Your comments will receive careful consideration at a meeting of the responsible technical committee,¹ which you may attend.

9.1.2 Cool the powder to room temperature in a desiccator.

9.1.3 Follow the procedure outlined in steps 10.2 – 10.2.5 (moving start).

NOTE 1—Stationary start analysis is only possible for some higher apparent density tungsten-based powders that will wholly fit in the flowmeter funnel, due to the volume of powder required for the test.

9.1.4 Repeat steps 10.2.1 – 10.2.5, using the identical calibration powder sample for all the tests, until five flow times, the extremes of which shall not differ by more than 0.4 s have been recorded.

9.1.5 The average of these flow times, reported to the nearest 0.1 s, shall be stamped or engraved on the bottom of the funnel. The flow time for a new funnel shall be $31.0\text{ s} \pm 0.5\text{ s}$.

9.1.6 It is recommended that the flow time be checked using the calibration powder at least every six months, using the procedure outlined above. If the flow rate has changed from that marked on the funnel, the new correction factor will be 31.0 divided by this new flow time. Before adopting the new correction factor, however, it is recommended that the cause of the change be investigated. If the flow time has decreased (faster flow), it is probable that repeated use has burnished the orifice and the new correction factor may be used. An increase in flow time (slower flow), may indicate a plating of soft powder upon the orifice. This should be removed carefully with the aid of a pipe cleaner and the calibration test re-run; the new correction factor being calculated if required. It is recommended that the use of the funnel be discontinued after the flow time of the calibration powder has decreased such that the flow time is less than 28 s.

10. Procedure

10.1 *Method 1*—Stationary Powder Start to Flow Measurement: Measurement (see Note 1):

10.1.1 Weigh the required mass of powder, as sampled, into a clean weighing dish. Use 150.0 g of powder for ferrous and copper-based materials, and 200.0 g for tungsten-based powders. Appropriate quantities for other powders shall be determined by experiment.

10.1.2 Block the discharge orifice at the bottom of the funnel with a dry or gloved finger.

10.1.3 Carefully pour the test portion of powder into the center of the Carney funnel without any tapping, vibration or movement of the funnel.

10.1.4 Place the emptied weighing dish on the flowmeter stand directly under the funnel orifice.

10.1.5 Remove your finger from the discharge orifice.

10.1.6 If the powder fails to start flowing, one light tap on the funnel rim is permitted. Further tapping of the funnel, however, or poking or stirring of the powder in the funnel with a wire or any other implement is not permitted.

10.1.7 Start the timing device the instant the powder begins to exit the orifice.

10.1.8 Stop the timing device the instant the last of the powder exits the orifice.

10.1.9 Record the elapsed time to the nearest 0.1 s.

10.1.10 More than one flow test may be run if desired. Use a fresh quantity of powder (test portion) for each flow test. Average the flow times.

10.2 *Method 2*—Moving Powder Start to Flow Measurement:

10.2.1 Place an empty receptacle directly under the discharge orifice.