



Designation: ~~D4194 – 03 (Reapproved 2014)~~ D4194 – 23

# Standard Test Methods for Operating Characteristics of Reverse Osmosis and Nanofiltration Devices<sup>1</sup>

This standard is issued under the fixed designation D4194; the number immediately following the designation indicates the year of original adoption or, in the case of revision, the year of last revision. A number in parentheses indicates the year of last reapproval. A superscript epsilon ( $\epsilon$ ) indicates an editorial change since the last revision or reapproval.

## 1. Scope

1.1 These test methods cover the determination of the operating characteristics of reverse osmosis devices using standard test conditions and are not necessarily applicable to natural waters. Three test methods are given, as follows:

	Sections
Test Method A—Brackish Water Reverse Osmosis Devices	<del>8 – 13</del>
Test Method A—Brackish Water Reverse Osmosis Devices	<del>8 – 14</del>
Test Method B—Nanofiltration Devices	<del>14 – 19</del>
Test Method B—Nanofiltration Devices	<del>15 – 21</del>
Test Method B—Seawater Reverse Osmosis Devices	<del>20 – 25</del>
Test Method B—Seawater Reverse Osmosis Devices	<del>22 – 28</del>

1.2 The values stated in SI units are to be regarded as standard. No other units of measurement are included in this standard.

1.3 *This standard does not purport to address all of the safety concerns, if any, associated with its use. It is the responsibility of the user of this standard to establish appropriate safety and health safety, health, and environmental practices and determine the applicability of regulatory limitations prior to use.*

1.4 *This international standard was developed in accordance with internationally recognized principles on standardization established in the Decision on Principles for the Development of International Standards, Guides and Recommendations issued by the World Trade Organization Technical Barriers to Trade (TBT) Committee.*

## 2. Referenced Documents

### 2.1 ASTM Standards:<sup>2</sup>

[D512 Test Methods for Chloride Ion in Water](#) (Withdrawn 2021)<sup>3</sup>

[D1125 Test Methods for Electrical Conductivity and Resistivity of Water](#) (Withdrawn 2023)<sup>3</sup>

[D1129 Terminology Relating to Water](#)

[D1193 Specification for Reagent Water](#)

[D6161 Terminology Used for Microfiltration, Ultrafiltration, Nanofiltration, and Reverse Osmosis Membrane Processes](#)

<sup>1</sup> These test methods are under the jurisdiction of ASTM Committee D19 on Water and are the direct responsibilities of Subcommittee D19.08 on Membranes and Ion Exchange Materials.

Current edition approved Jan. 1, 2014; Jan. 1, 2023. Published February 2014; February 2023. Originally approved in 1982. Last previous edition approved in 2008 as D4194 – 03 (2008); (2014). DOI: 10.1520/D4194-03R14; 10.1520/D4194-23.

<sup>2</sup> For referenced ASTM standards, visit the ASTM website, [www.astm.org](http://www.astm.org), or contact ASTM Customer Service at [service@astm.org](mailto:service@astm.org). For *Annual Book of ASTM Standards* volume information, refer to the standard's Document Summary page on the ASTM website.

<sup>3</sup> The last approved version of this historical standard is referenced on [www.astm.org](http://www.astm.org).

### 3. Terminology

3.1 *Definitions*—For definitions of terms used in these test methods, refer to Terminology [D1129](#) and [D6161](#).

#### 3.1 Definitions:

3.1.1 For definitions of terms used in these test methods, refer to Terminology [D1129](#) and [D6161](#).

3.1.2 *brackish water, n*—water that contains dissolved matter at an approximate concentration range from 1000 to 30 000 mg/L.

3.1.3 *concentrate, n*—stream exiting a crossflow membrane device that has increased concentration of solutes and particles over the feed stream; portion of the feed stream that does not pass through the membrane; the stream in which dissolved solids or particulates, or both, are concentrated in a membrane separation process.

3.1.4 *hollow-fiber (HF) membrane*—self-supporting membrane fibers that have a hollow bore like a cylinder; in reverse osmosis, the membrane is usually on the outside with the bore conveying the permeate; in ultra and micro filtration, the membrane might be on the inside or outside of the fiber.

3.1.5 *nanofiltration (NF), n*—crossflow process with pore sizes designed to remove selected salts and most organics above about 300 molecular weight range, sometimes referred to as loose RO; a pressure-driven membrane separation process in which particles and dissolved molecules larger than about 2 nm are rejected.

3.1.6 *permeate, n*—that portion of the feed which passes through the membrane.

3.1.7 *reverse osmosis (RO), n*—separation process in which one component of a solution is removed from another component by flowing the feed stream under pressure across a semipermeable membrane that causes selective movement of solvent against its osmotic pressure difference; RO removes ions based on electrochemical forces, colloids, and organics down to 150 molecular weight; may also be called hyperfiltration.

3.1.8 *sea water, n*—water with approximate concentration of total dissolved solids ranging from 30 000 to 60 000 mg/L.

3.1.9 *spiral wound membrane, n*—a flat sheet membrane with one or more feed channel spacers, and barrier layers, all of which are rolled into a spiral configuration.

3.1.10 *tubular membrane, n*—the element, similar to hollow-fiber but with a bore diameter >5 mm (see hollow-fiber); used mostly in MF and UF and sometimes with RO and NF when particulate loading is high.

### 4. Summary of Test Methods

4.1 These test methods consist of determining the desalinating ability and permeate flow rate of reverse osmosis and nanofiltration devices. They are applicable to both new and used reverse osmosis or nanofiltration devices.

### 5. Significance and Use

5.1 Reverse osmosis and nanofiltration desalinating devices can be used to produce potable water from brackish supplies (<10 000 mg/L) and seawater as well as to upgrade the quality of industrial water. These test methods permit the measurement of the performance of reverse osmosis devices using standard sets of conditions and are intended for short-term testing (<24 h). These test methods can be used to determine changes that may have occurred in the operating characteristics of reverse osmosis and nanofiltration devices but are not intended to be used for plant design.

### 6. Reagents

6.1 *Purity of Reagents*—Reagent grade chemicals shall be used in all tests. Unless otherwise indicated, it is intended that all reagents shall conform to the specifications of the Committee on Analytical Reagents of the American Chemical Society, where

such specifications are available. <sup>4</sup> Other grades may be used, provided it is first ascertained that the reagent is of sufficiently high purity to permit its use without lessening the accuracy of the determination.

6.2 *Purity of Water*—Unless otherwise indicated, references to water shall be understood to mean Type III reagent conforming to Specification D1193.

## 7. Apparatus

7.1 The apparatus for both methods is schematically described in Fig. 1 and Fig. 2. A conductivity meter can be used to determine

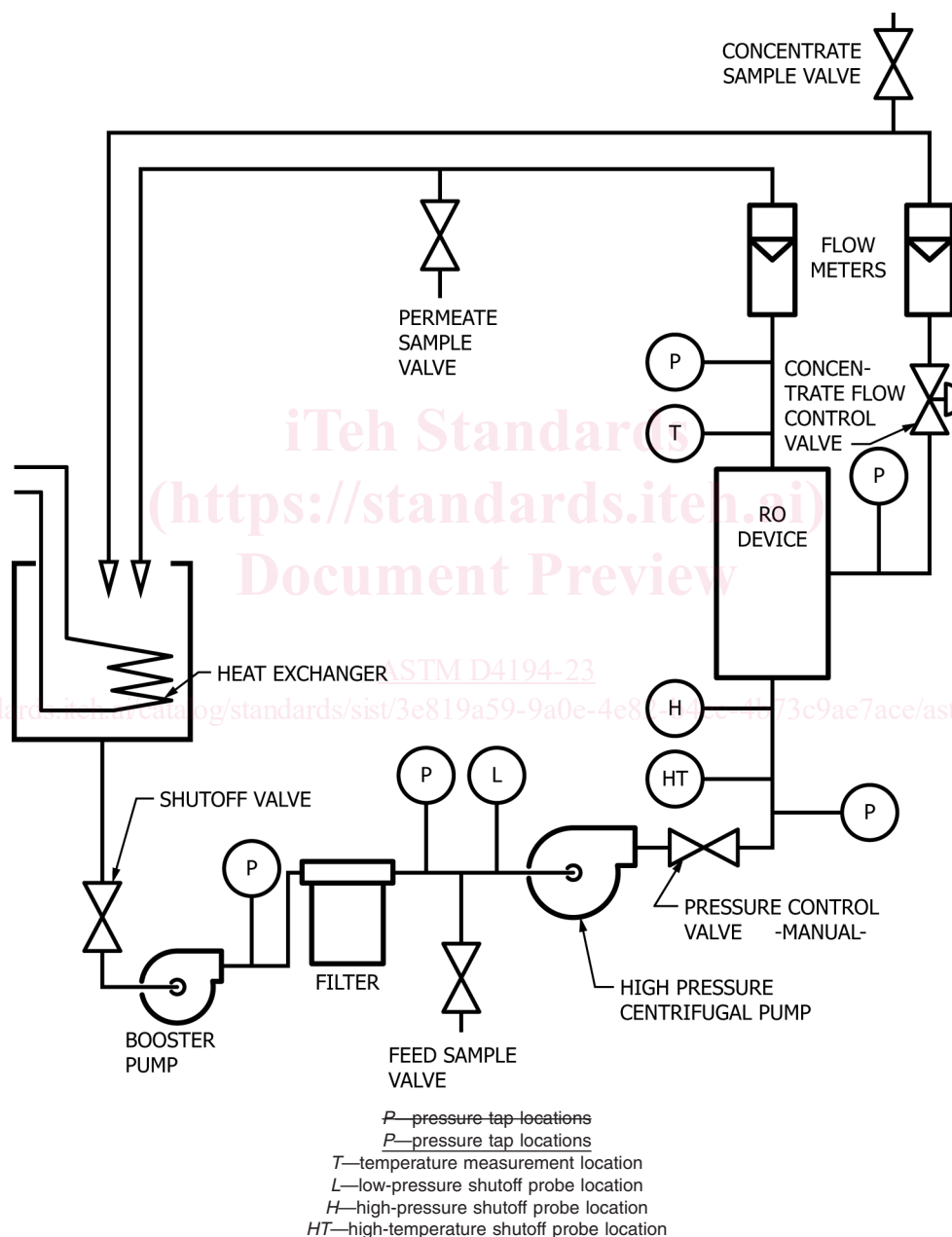

FIG. 1 Centrifugal High-Pressure Pump System Piping Diagram

<sup>4</sup> *Reagent Chemicals, American Chemical Society Specifications, ACS Reagent Chemicals, Specifications and Procedures for Reagents and Standard-Grade Reference Materials*, American Chemical Society, Washington, DC. For suggestions on the testing of reagents not listed by the American Chemical Society, see *Analar Standards for Laboratory Chemicals*, BDH Ltd., Poole, Dorset, U.K., and the *United States Pharmacopeia and National Formulary*, U.S. Pharmacopeial Convention, Inc. (USPC), Rockville, MD.

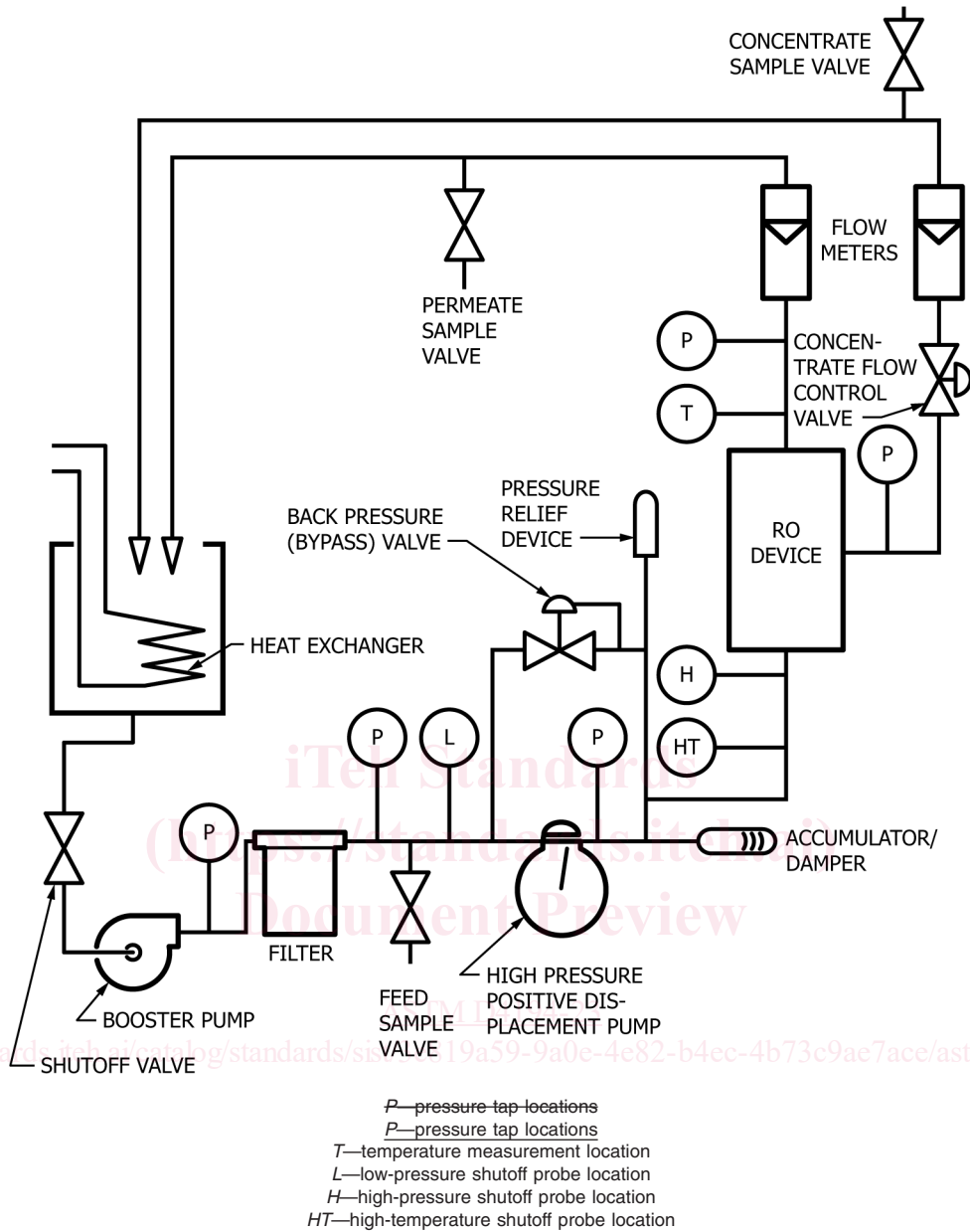

FIG. 2 Positive Displacement High-Pressure Pump System Piping Diagram

the salt concentration in accordance with Test Methods D1125.

## 7.2 Installation:

7.2.1 Materials of construction shall be of high-quality stainless steel (Type 316) or plastic for all wetted parts to prevent contamination of the feed solution by corrosion products. Do not use reactive piping material such as plain carbon steel, galvanized or cadmium-plated carbon steel, and cast iron for piping. Take care to ensure that no contamination will occur from oil films on new metal piping, release agents on raw plastic components, or from feed solutions previously used in the system. If materials are suspect, thoroughly clean or degrease or both, before use. All pressurized components whether stainless steel or plastic should be designed based on the manufacturer's working pressure rating. Review manufacturer's rating for compliance with standard engineering practice.

7.2.2 The reverse osmosis testing apparatus, represented schematically in **Fig. 1** using a centrifugal pump, consists of a feed holding tank equipped with a thermostated heat ex-changer system to maintain the feed solution at the desired temperature, a booster pump, a high-pressure centrifugal pump, and a reverse osmosis device. Use a valve with a minimum flow restriction (for example, ball valve or plug valve) for the shut-off valve to prevent excessive pressure drop. The filter can be either a strainer (100-mesh) or a 5- $\mu\text{m}$  filter (based on supplier's recommendation). Use a pressure control valve such as a ball valve for throttling the pump discharge. A flow control valve is needed to regulate the concentrate flow. A manual throttling valve, such as a needle valve, is sufficient for this application unless the flows are so low that plugging could become a problem. In that case, use a long coil of high-pressure media tubing to take the entire pressure drop through the tubing. Cut the tubing to length for the required flow.

7.2.3 See **Fig. 2** for a schematic piping diagram for a positive displacement high-pressure pump test system. Valves and arrangements are similar to the centrifugal system except for the high-pressure pump piping. The back-pressure regulator on the by-pass controls pressure on the pump discharge line. Under no circumstances install throttling valves directly on a positive displacement pump discharge line. An accumulator is required to minimize pressure pulsations ( $<1\%$  of value) if a reciprocating piston-type positive displacement pump is used to feed the reverse osmosis device.

7.2.4 Operate the apparatus by drawing the feed solution from the tank and pumping it through the reverse osmosis device under pressure. Return both the concentrate stream and the permeate to the feed tank so that its volume and solute concentration remain constant. Use the heat exchanger coils in the feed tank to adjust the feed to specified operating temperature and thereafter use to remove the energy load generated by the pump. Monitor the permeate temperature very near the reverse osmosis device (within 500 mm). Pressure gages before and after the reverse osmosis device give the feed pressure and the pressure drop across the device ( $\Delta P$ ; feed pressure – concentrate pressure). Locate these gages as close as possible to the reverse osmosis device. Measure the concentrate and permeate flow rates with calibrated flowmeters from which the feed rate to the device may be determined. Remove samples of these two streams through sampling valves for conductivity/concentration measurements. Sample the feed using the feed sample valve. Direct the return flows in the feed tank to provide adequate mixing.

7.3 *Systems*—To protect the reverse osmosis device and the high-pressure pump from abnormal operating conditions, install limit controls in the system. An electric limit control is used to shut down the high-pressure feed pump. The limit control circuit should have a manual reset relay in it so that when it shuts down it will not automatically restart. See **Fig. 1** and **Fig. 2** for the limit control locations. Their functions are as follows:

7.3.1 *High-Pressure Shut-Off*—Set the cutoff point in accordance with the supplier's recommendations (protects the reverse osmosis device against excessive pressure).

7.3.2 *Low-Pressure Shut-Off*—Set the cutoff point at a gage pressure of 103 kPa (15 psi) (shuts the system down when the pump water supply is interrupted and thus protects the reverse osmosis pump).

7.3.3 *High-Temperature Shut-Off*—Set the maximum temperature at  $30^{\circ}\text{C}$  to  $30^{\circ}\text{C}$  (protects the reverse osmosis device against excessive temperature).

## 7.4 Instrumentation:

7.4.1 *Pressure*—See **Fig. 1** and **Fig. 2** for pressure tap locations. Use a single gage equipped with a high-pressure “quick-connect” or Taylor plug gage fitting for measuring individual pressures and device pressure drop ( $\Delta P$ ). Individual gages are also satisfactory but not as reliable as a “quick-connect” test gage or a special  $\Delta P$  gage. Use pressure snubbers to prevent pulsation damage to gages, and calibrate all pressure gages.

7.4.2 *Temperature*—See Fig. 1 and Fig. 2 for temperature-measurement locations. Calibrated dial thermometers with the probe immersed in the flowing water should provide good data.

7.4.3 *Permeate Back-Pressure Considerations*—It is permissible to operate reverse osmosis devices with a back-pressure on the permeate. The maximum recommended back-pressure for these methods is 35 kPa (5 psi). This pressure is more than adequate for transferring the permeate back to the feed tank.

## TEST METHOD A—BRACKISH WATER REVERSE OSMOSIS DEVICES

### ~~8. Scope~~

~~8.1 This test method covers the determination of the operating characteristics of brackish water reverse osmosis devices using standard test conditions and can be used for all types of devices (tubular, spiral wound, and hollow fiber).~~

### 8. Scope

8.1 This test method covers the determination of the operating characteristics of brackish water reverse osmosis devices using standard test conditions and can be used for all types of devices (tubular, spiral wound, and hollow fiber).

### 9. Summary of Test Method

9.1 The test method provides for at least three different concentrations of sodium chloride feed solution.

### 10. Reagents and Materials

10.1 *Sodium Chloride Feed Solution (5.0 g/L)*—Dissolve enough sodium chloride (NaCl) in water to make a solution containing in each litre 5.0 g of NaCl.

10.2 *Sodium Chloride Feed Solution (1.5 g/L)*—Dissolve enough sodium chloride (NaCl) in water to make a solution containing in each litre 1.5 g of NaCl.

10.3 *Sodium Chloride Feed Solution (0.5 g/L)*—Dissolve enough sodium chloride (NaCl) in water to make a solution containing in each litre 0.5 g of NaCl.

10.4 *Sodium Chloride Feed Solutions, Optional*—Other concentrations of NaCl solutions (<10 g/L) can be used.

### 11. Procedure

#### 11.1 *Start-Up and Operating Procedure:*

11.1.1 If the reverse osmosis device contains sanitizing or winterizing agents, or both, flush the device in accordance with the supplier's recommendations.

11.1.2 Make preliminary checks to make sure all fittings are tight, all components are operational, and the feed solution is at the proper concentration and temperature. Before energizing the high-pressure pump, the low-pressure switch must be off for start-up to complete the circuit past the low-pressure cutout. Energize the high-pressure pump momentarily to check proper rotation.

11.1.3 Open the feed supply valve, the concentrate flow control valve, the pump by-pass on the positive displacement feed pump, or the centrifugal pump throttling valve. Start the booster pump and then the high-pressure pump.

11.1.4 Bring the feed pressure to a gage pressure that is in accordance with the specifications of membrane manufacturer for a given element model. It is possible that the by-pass valve or the throttling valve (depending on pump system) and the concentrate flow control valve may need to be adjusted simultaneously. If necessary, another pressure agreed upon between the user and the supplier may be used.

11.1.5 Set concentrate flow in accordance with the supplier's recommendation by adjusting the concentrate flow control valve. But maintain conversion within  $\pm 2\%$  of the supplier's recommendation.

11.1.6 Recheck and adjust if necessary both the concentrate flow and feed pressure to give the selected values for flow and pressure.

11.1.7 Check and adjust the cooling system in the feed solution to give a permeate temperature of  $25 \pm 1^\circ\text{C}$ .

11.1.8 Once sustained operation is attained, energize the low-pressure shut-off switch.

**iTeh Standards**  
**(<https://standards.iteh.ai>)**  
**Document Preview**

[ASTM D4194-23](#)

<https://standards.iteh.ai/catalog/standards/sist/3e819a59-9a0e-4e82-b4ec-4b73c9ae7ace/astm-d4194-23>