



Designation: C1161 – 18 (Reapproved 2023)

Standard Test Method for Flexural Strength of Advanced Ceramics at Ambient Temperature¹

This standard is issued under the fixed designation C1161; the number immediately following the designation indicates the year of original adoption or, in the case of revision, the year of last revision. A number in parentheses indicates the year of last reapproval. A superscript epsilon (ϵ) indicates an editorial change since the last revision or reapproval.

This standard has been approved for use by agencies of the U.S. Department of Defense.

1. Scope

1.1 This test method covers the determination of flexural strength of advanced ceramic materials at ambient temperature. Four-point- $1/4$ -point and three-point loadings with prescribed spans are the standard as shown in Fig. 1. Rectangular specimens of prescribed cross-section sizes are used with specified features in prescribed specimen-fixture combinations. Test specimens may be 3 by 4 by 45 to 50 mm in size that are tested on 40-mm outer span four-point or three-point fixtures. Alternatively, test specimens and fixture spans half or twice these sizes may be used. The method permits testing of machined or as-fired test specimens. Several options for machining preparation are included: application matched machining, customary procedure, or a specified standard procedure. This method describes the apparatus, specimen requirements, test procedure, calculations, and reporting requirements. The test method is applicable to monolithic or particulate- or whisker-reinforced ceramics. It may also be used for glasses. It is not applicable to continuous fiber-reinforced ceramic composites.

1.2 The values stated in SI units are to be regarded as the standard. The values given in parentheses are for information only.

1.3 *This standard does not purport to address all of the safety concerns, if any, associated with its use. It is the responsibility of the user of this standard to establish appropriate safety, health, and environmental practices and determine the applicability of regulatory limitations prior to use.*

1.4 *This international standard was developed in accordance with internationally recognized principles on standardization established in the Decision on Principles for the Development of International Standards, Guides and Recommendations issued by the World Trade Organization Technical Barriers to Trade (TBT) Committee.*

¹ This test method is under the jurisdiction of ASTM Committee C28 on Advanced Ceramics and is the direct responsibility of Subcommittee C28.01 on Mechanical Properties and Performance.

Current edition approved Jan. 1, 2023. Published February 2023. Originally approved in 1990. Last previous edition approved in 2018 as C1161 – 18. DOI: 10.1520/C1161-18R23.

2. Referenced Documents

2.1 ASTM Standards:²

C1239 Practice for Reporting Uniaxial Strength Data and Estimating Weibull Distribution Parameters for Advanced Ceramics

C1322 Practice for Fractography and Characterization of Fracture Origins in Advanced Ceramics

C1368 Test Method for Determination of Slow Crack Growth Parameters of Advanced Ceramics by Constant Stress Rate Strength Testing at Ambient Temperature

E4 Practices for Force Calibration and Verification of Testing Machines

E337 Test Method for Measuring Humidity with a Psychrometer (the Measurement of Wet- and Dry-Bulb Temperatures)

2.2 Military Standard:³

MIL-STD-1942(MR) Flexural Strength of High Performance Ceramics at Ambient Temperature

3. Terminology

3.1 Definitions:

3.1.1 *complete gage section, n*—the portion of the specimen between the two outer bearings in four-point flexure and three-point flexure fixtures.

NOTE 1—In this standard, the complete four-point flexure gage section is twice the size of the inner gage section. Weibull statistical analysis only includes portions of the specimen volume or surface which experience tensile stresses.

3.1.2 *flexural strength, $[FL^{-2}]$, n*—a measure of the ultimate strength of a specified beam in bending.

3.1.3 *four-point- $1/4$ -point flexure, n*—configuration of flexural strength testing where a specimen is symmetrically loaded at two locations that are situated one-quarter of the overall span away from the outer two support bearings (see Fig. 1).

² For referenced ASTM standards, visit the ASTM website, www.astm.org, or contact ASTM Customer Service at service@astm.org. For *Annual Book of ASTM Standards* volume information, refer to the standard's Document Summary page on the ASTM website.

³ Available from Standardization Documents Order Desk, DODSSP, Bldg. 4, Section D, 700 Robbins Ave., Philadelphia, PA 19111-5098, <http://www.dodssp.daps.mil>.

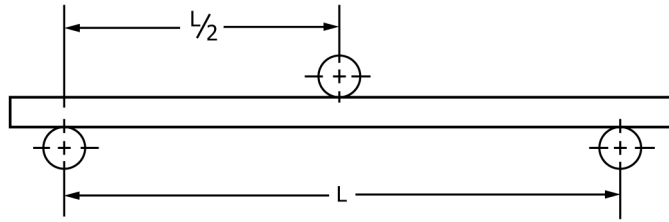
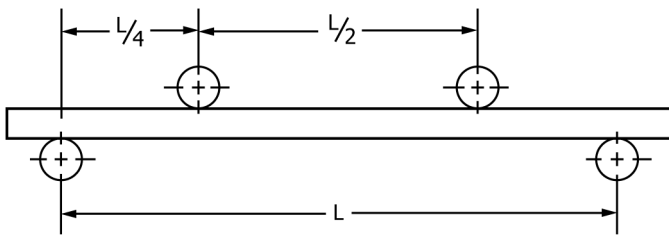

NOTE 1—Configuration:

A: L = 20 mm

B: L = 40 mm

C: L = 80 mm

FIG. 1 The Four-Point-1/4-Point and Three-Point Fixture Configuration

3.1.4 *fully articulating fixture, n*—a flexure fixture designed to be used either with flat and parallel specimens or with uneven or nonparallel specimens. The fixture allows full independent articulation, or pivoting, of all rollers about the specimen long axis to match the specimen surface. In addition, the upper or lower pairs are free to pivot to distribute force evenly to the bearing cylinders on either side.

NOTE 2—See Annex A1 for schematic illustrations of the required pivoting movements.

NOTE 3—A three-point fixture has the inner pair of bearing cylinders replaced by a single bearing cylinder.

3.1.5 *inert flexural strength, $[FL^{-2}]$, n*—a measure of the strength of specified beam in bending as determined in an appropriate inert condition whereby no slow crack growth occurs.

NOTE 4—An inert condition may be obtained by using vacuum, low temperatures, very fast test rates, or any inert media.

3.1.6 *inherent flexural strength, $[FL^{-2}]$, n*—the flexural strength of a material in the absence of any effect of surface grinding or other surface finishing process, or of extraneous damage that may be present. The measured inherent strength is in general a function of the flexure test method, test conditions, and test specimen size.

3.1.7 *inner gage section, n*—the portion of the specimen between the inner two bearings in a four-point flexure fixture.

3.1.8 *semi-articulating fixture, n*—a flexure fixture designed to be used with flat and parallel specimens. The fixture allows some articulation, or pivoting, to ensure the top pair (or bottom pair) of bearing cylinders pivot together about an axis parallel to the specimen long axis, in order to match the specimen

surfaces. In addition, the upper or lower pairs are free to pivot to distribute force evenly to the bearing cylinders on either side.

NOTE 5—See Annex A1 for schematic illustrations of the required pivoting movements.

NOTE 6—A three-point fixture has the inner pair of bearing cylinders replaced by a single bearing cylinder.

3.1.9 *slow crack growth (SCG), n*—subcritical crack growth (extension) which may result from, but is not restricted to, such mechanisms as environmentally assisted stress corrosion or diffusive crack growth.

3.1.10 *three-point flexure, n*—configuration of flexural strength testing where a specimen is loaded at a location midway between two support bearings (see Fig. 1).

4. Significance and Use

4.1 This test method may be used for material development, quality control, characterization, and design data generation purposes. This test method is intended to be used with ceramics whose strength is 50 MPa (~7 ksi) or greater.

4.2 The flexure stress is computed based on simple beam theory with assumptions that the material is isotropic and homogeneous, the moduli of elasticity in tension and compression are identical, and the material is linearly elastic. The average grain size should be no greater than one-fiftieth of the beam thickness. The homogeneity and isotropy assumption in the standard rule out the use of this test for continuous fiber-reinforced ceramics.

4.3 Flexural strength of a group of test specimens is influenced by several parameters associated with the test procedure. Such factors include the loading rate, test environment, specimen size, specimen preparation, and test fixtures. Specimen sizes and fixtures were chosen to provide a balance between practical configurations and resulting errors, as discussed in MIL-STD-1942(MR) and Refs (1, 2).⁴ Specific fixture and specimen configurations were designated in order to permit ready comparison of data without the need for Weibull-size scaling.

4.4 The flexural strength of a ceramic material is dependent on both its inherent resistance to fracture and the size and severity of flaws. Variations in these cause a natural scatter in test results for a sample of test specimens. Fractographic analysis of fracture surfaces, although beyond the scope of this standard, is highly recommended for all purposes, especially if the data will be used for design as discussed in MIL-STD-1942(MR) and Refs (2-5) and Practices C1322 and C1239.

4.5 The three-point test configuration exposes only a very small portion of the specimen to the maximum stress. Therefore, three-point flexural strengths are likely to be much greater than four-point flexural strengths. Three-point flexure has some advantages. It uses simpler test fixtures, it is easier to adapt to high temperature and fracture toughness testing, and it is sometimes helpful in Weibull statistical studies. However,

⁴ The boldface numbers in parentheses refer to the references at the end of this test method.

four-point flexure is preferred and recommended for most characterization purposes.

4.6 This method determines the flexural strength at ambient temperature and environmental conditions. The flexural strength under ambient conditions may or may not necessarily be the inert flexural strength.

NOTE 7—time dependent effects may be minimized through the use of inert testing atmosphere such as dry nitrogen gas, oil, or vacuum. Alternatively, testing rates faster than specified in this standard may be used. Oxide ceramics, glasses, and ceramics containing boundary phase glass are susceptible to slow crack growth even at room temperature. Water, either in the form of liquid or as humidity in air, can have a significant effect, even at the rates specified in this standard. On the other hand, many ceramics such as boron carbide, silicon carbide, aluminum nitride, and many silicon nitrides have no sensitivity to slow crack growth at room temperature and the flexural strength in laboratory ambient conditions is the inert flexural strength.

5. Interferences

5.1 The effects of time-dependent phenomena, such as stress corrosion or slow crack growth on strength tests conducted at ambient temperature, can be meaningful even for the relatively short times involved during testing. Such influences must be considered if flexure tests are to be used to generate design data. Slow crack growth can lead a rate dependency of flexural strength. The testing rate specified in this standard may or may not produce the inert flexural strength whereby negligible slow crack growth occurs. See Test Method C1368.

5.2 Surface preparation of test specimens can introduce machining microcracks which may have a pronounced effect on flexural strength. Machining damage imposed during specimen preparation can be either a random interfering factor, or an inherent part of the strength characteristic to be measured. With proper care and good machining practice, it is possible to obtain fractures from the material’s natural flaws. Surface preparation can also lead to residual stresses. Universal or standardized test methods of surface preparation do not exist. It should be understood that final machining steps may or may not negate machining damage introduced during the early course or intermediate machining.

5.3 This test method allows several options for the machining of specimens, and includes a general procedure (“Standard” procedure, 7.2.4), which is satisfactory for many (but certainly not all) ceramics. The general procedure used progressively finer longitudinal grinding steps that are designed to minimize subsurface microcracking. Longitudinal grinding aligns the most severe subsurface microcracks parallel to the specimen tension stress axis. This allows a greater opportunity to measure the inherent flexural strength or “potential strength” of the material as controlled by the material’s natural flaws. In contrast, transverse grinding aligns the severest subsurface machining microcracks perpendicular to the tension stress axis and the specimen is more likely to fracture from the machining microcracks. Transverse-ground specimens in many instances may provide a more “practical strength” that is relevant to machined ceramic components whereby it may not be possible to favorably align the machining direction. Transverse-ground specimens may be tested in accordance with 7.2.2. Data from transverse-ground specimens may correlate better with data

from biaxial disk or plate strength tests, wherein machining direction cannot be aligned.

6. Apparatus

6.1 Loading—Specimens may be loaded in any suitable testing machine provided that uniform rates of direct loading can be maintained. The force measuring system shall be free of initial lag at the loading rates used and shall be equipped with a means for retaining read-out of the maximum force applied to the specimen. The accuracy of the testing machine shall be in accordance with Practices E4 but within 0.5 %.

6.2 Four-Point Flexure—Four-point-1/4-point fixtures (Fig. 1) shall have support and loading spans as shown in Table 1.

6.3 Three-Point Flexure—Three-point fixtures (Fig. 1) shall have a support span as shown in Table 1.

6.4 Bearings—Three- and four-point flexure:

6.4.1 Cylindrical bearing edges shall be used for the support of the test specimen and for the application of load. The cylinders shall be made of hardened steel which has a hardness no less than HRC 40 or which has a yield strength no less than 1240 MPa (~180 ksi). Alternatively, the cylinders may be made of a ceramic with an elastic modulus between 2.0 and 4.0 × 10⁵ MPa (30 to 60 × 10⁶ psi) and a flexural strength no less than 275 MPa (~40 ksi). The portions of the test fixture that support the bearings may need to be hardened to prevent permanent deformation. The cylindrical bearing length shall be at least three times the specimen width. The above requirements are intended to ensure that ceramics with strengths up to 1400 MPa (~200 ksi) and elastic moduli as high as 4.8 × 10⁵ MPa (70 × 10⁶ psi) can be tested without fixture damage. Higher strength and stiffer ceramic specimens may require harder bearings.

6.4.2 The bearing cylinder diameter shall be approximately 1.5 times the beam depth of the test specimen size employed. See Table 2.

6.4.3 The bearing cylinders shall be carefully positioned such that the spans are accurate within ±0.10 mm. The load application bearing for the three-point configurations shall be positioned midway between the support bearing within ±0.10 mm. The load application (inner) bearings for the four-point configurations shall be centered with respect to the support (outer) bearings within ±0.10 mm.

6.4.4 The bearing cylinders shall be free to rotate in order to relieve frictional constraints (with the exception of the middle-load bearing in three-point flexure which need not rotate). This can be accomplished by mounting the cylinders in needle bearing assemblies, or more simply by mounting the cylinders as shown in Figs. 2 and 3. The cylinders are held in place by low-stiffness springs, rubber bands, or magnets. (If these fixtures are used for some fracture toughness tests, whereby very low forces are used to break pre-cracked test specimens,

TABLE 1 Fixture Spans

Configuration	Support Span (L), mm	Loading Span, mm
A	20	10
B	40	20
C	80	40

TABLE 2 Nominal Bearing Diameters

Configuration	Diameter, mm
A	2.0 to 2.5
B	4.5
C	9.0

then very low-stiffness rubber bands or springs should be used.) **Annex A1** illustrates the action required of the bearing cylinders. Note that the outer support bearings roll *outward* and the inner loading bearings roll *inward*.

6.5 Semi-Articulating Four-Point Fixture—Specimens prepared in accordance with the parallelism requirements of **7.1** may be tested in a semi-articulating fixture as illustrated in **Fig. 2** and in **Fig. A1.1a**. All four bearings shall be free to roll. The two inner bearings shall be parallel to each other to within 0.015 mm over their length and they shall articulate together as a pair. The two outer bearings shall be parallel to each other to within 0.015 mm over their length and they shall articulate together as a pair. The inner bearings shall be supported independently of the outer bearings. All four bearings shall rest uniformly and evenly across the specimen surfaces. The fixture shall be designed to apply equal load to all four bearings.

6.6 Fully Articulating Four-Point Fixture—Specimens that are as-fired, heat treated, or oxidized often have slight twists or unevenness. Specimens which do not meet the parallelism requirements of **7.1** shall be tested in a fully articulating fixture as illustrated in **Fig. 3** and in **Fig. A1.1b**. Well-machined specimens may also be tested in fully articulating fixtures. All four bearings shall be free to roll. One bearing need not articulate. The other three bearings shall articulate to match the specimen's surface. All four bearings shall rest uniformly and evenly across the specimen surfaces. The fixture shall apply equal load to all four bearings.

6.7 Semi-Articulated Three-Point Fixture—Specimens prepared in accordance with the parallelism requirements of **7.1** may be tested in a semi-articulating fixture. The middle bearing shall be fixed and not free to roll. The two outer bearings shall be parallel to each other to within 0.015 mm over their length. The two outer bearings shall articulate together as a pair to match the specimen surface, or the middle bearing shall articulate to match the specimen surface. All three bearings shall rest uniformly and evenly across the specimen surface. The fixture shall be designed to apply equal load to the two outer bearings.

6.8 Fully Articulated Three-Point Flexure—Specimens that do not meet the parallelism requirements of **7.1** shall be tested in a fully articulating fixture. Well-machined specimens may also be tested in a fully articulating fixture. The two support (outer) bearings shall be free to roll outwards. The middle bearing shall not roll. Any two of the bearings shall be capable of articulating to match the specimen surface. All three bearings shall rest uniformly and evenly across the specimen surface. The fixture shall be designed to apply equal load to the two outer bearings.

6.9 The fixture shall be stiffer than the specimen, so that most of the crosshead travel is imposed onto the specimen.

6.10 Micrometer—A micrometer with a resolution of 0.002 mm (or 0.0001 in.) or smaller should be used to measure the test specimen dimensions. The micrometer shall have flat anvil faces. The micrometer shall not have a ball tip or sharp tip since these might damage the test specimen if the specimen dimensions are measured prior to fracture. Alternative dimension measuring instruments may be used provided that they have a resolution of 0.002 mm (or 0.0001 in.) or finer and do no harm to the specimen.

7. Specimen

7.1 Specimen Size—Dimensions are given in **Table 3** and shown in **Fig. 4**. Cross-sectional dimensional tolerances are ± 0.13 mm for B and C specimens, and ± 0.05 mm for A. The parallelism tolerances on the four longitudinal faces are 0.015 mm for A and B and 0.03 mm for C. The two end faces need not be precision machined.

7.2 Specimen Preparation—Depending upon the intended application of the flexural strength data, use one of the following four specimen preparation procedures:

NOTE 8—This test method does not specify a test specimen surface finish. Surface finish may be misleading since a ground, lapped, or even polished surface may conceal hidden, beneath-the-surface cracking damage from rough or intermediate grinding.

7.2.1 As-Fabricated—The flexural specimen shall simulate the surface condition of an application where no machining is to be used; for example, as-cast, sintered, or injection-molded parts. No additional machining specifications are relevant. An edge chamfer is not necessary in this instance. As-fired specimens are especially prone to twist or warpage and might not meet the parallelism requirements. In this instance, a fully articulating fixture (**6.6** and **Fig. 3**) shall be used in testing.

7.2.2 Application-Matched Machining—The specimen shall have the same surface preparation as that given to a component. Unless the process is proprietary, the report shall be specific about the stages of material removal, wheel grits, wheel bonding, and the amount of material removed per pass.

7.2.3 Customary Procedures—In instances where a customary machining procedure has been developed that is completely satisfactory for a class of materials (that is, it induces no unwanted surface damage or residual stresses), this procedure shall be used.

7.2.4 Standard Procedures—In the instances where **7.2.1 – 7.2.3** are not appropriate, then **7.2.4** shall apply. This procedure shall serve as minimum requirements and a more stringent procedure may be necessary.

7.2.4.1 All grinding shall be done with an ample supply of appropriate filtered coolant to keep workpiece and wheel constantly flooded and particles flushed. Grinding shall be in two or three stages, ranging from coarse to fine rates of material removal. All machining shall be in the surface grinding mode, and shall be parallel to the specimen long axis shown in **Fig. 5**. No Blanchard or rotary grinding shall be used. Machine the four long faces in accordance with the following paragraphs. The two end faces do not require special machining.

7.2.4.2 Coarse grinding, if necessary, shall be with a diamond wheel no coarser than 150 grit. The stock removal rate

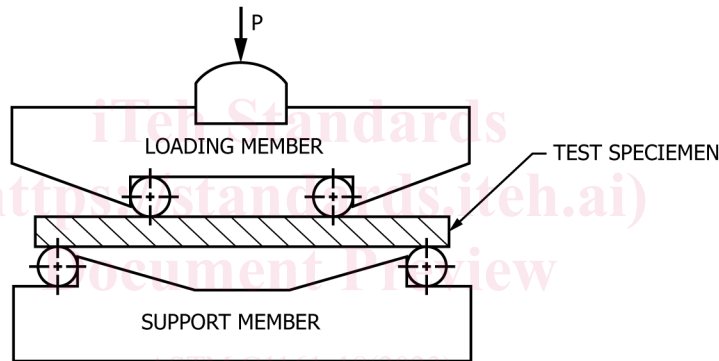
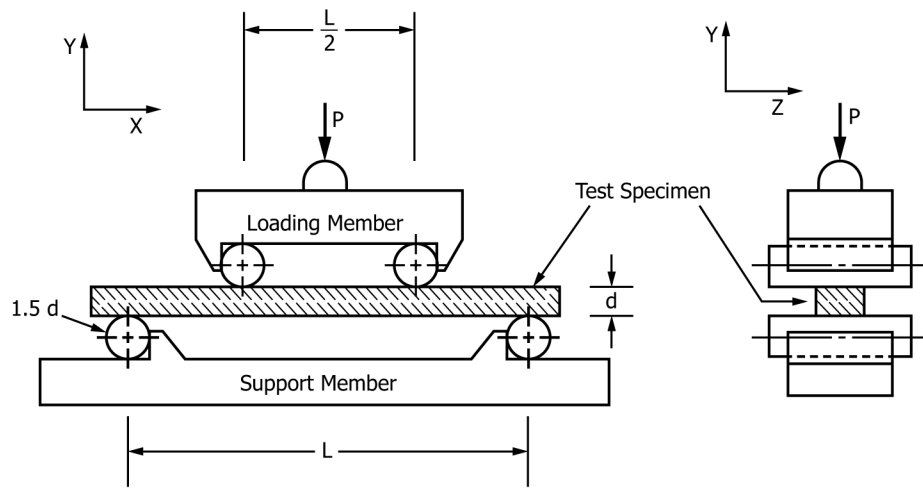

NOTE 1—Configuration:

A: $L = 20$ mm

B: $L = 40$ mm

C: $L = 80$ mm

NOTE 2—Load is applied through a ball which permits the loading member to tilt as necessary to ensure uniform loading.

NOTE 3—Bearing cylinders are held in place by low-stiffness springs, rubber bands, or magnets.

FIG. 2 Schematics of Two Semi-Articulating Four-Point Fixtures Suitable for Flat and Parallel Specimens

(wheel depth of cut) shall not exceed 0.03 mm (0.001 in.) per pass to the last 0.060 mm (0.002 in.) per face. Remove approximately equal stock from opposite faces.

7.2.4.3 Intermediate grinding, if utilized, should be done with a diamond wheel that is between 240 and 320 grit. The stock removal rate (wheel depth of cut) shall not exceed 0.006 mm (0.00025 in.) per pass to the last 0.020 mm (0.0008 in.) per face. Remove approximately equal stock from opposite faces.

7.2.4.4 Finish grinding shall be with a diamond wheel that is between 400 and 600 grit. The stock removal rate (wheel depth of cut) shall not exceed 0.006 mm (0.00025 in.) per pass. Final grinding shall remove no less than 0.020 mm (0.0008 in.) per face. The combined intermediate and final grinding stages shall remove no less than 0.060 mm (0.0025 in.) per face. Remove approximately equal stock from opposite faces.

7.2.4.5 Wheel speed should not be less than 25 m/sec (~1000 in./sec). Table speeds should not be greater than 0.25 m/sec (45 ft/min).

7.2.4.6 The procedures in 7.2.4 address diamond grit size for coarse, intermediate, and finish grinding but leaves the choice of bond system (resin, vitrified), diamond type (natural or synthetic, coated or uncoated, friability, shape, etc.) and concentration (percent of diamond in the wheel) to the discretion of the user.

NOTE 9—The sound of the grinding wheel during the grinding process may be a useful indicator of whether the grinding wheel condition and material removal conditions are appropriate. It is beyond the scope of this standard to specify the auditory responses, however.

7.2.4.7 Materials with low fracture toughness and a greater susceptibility to grinding damage may require finer grinding wheels at very low removal rates.

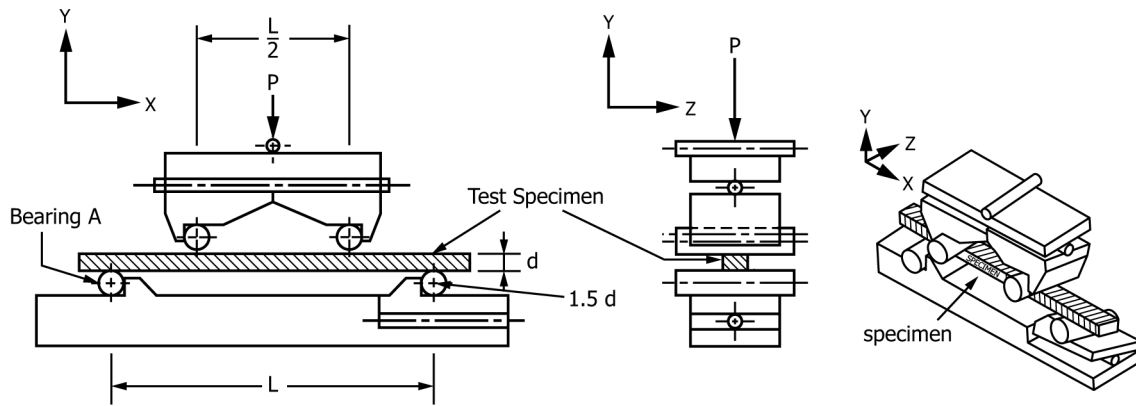

Note 1:

Configuration	L, mm
A	20
B	40
C	80

Note 2 – Bearing A is fixed so that it will not pivot about the x-axis. The other three bearings are free to pivot about the x-axis.

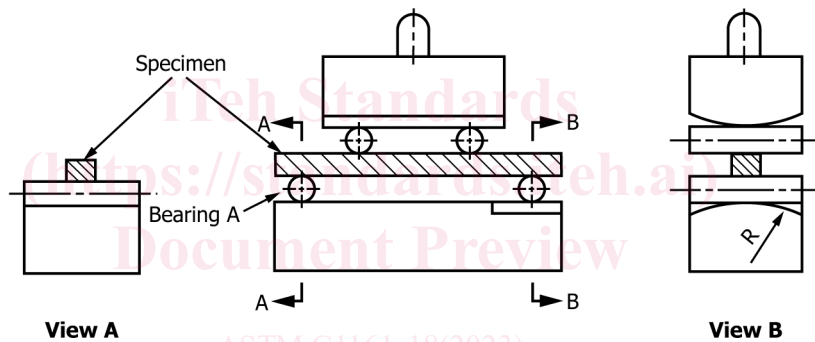

NOTE 1—Configuration:

- A: L = 20 mm
- B: L = 40 mm
- C: L = 80 mm

NOTE 2—Bearing A is fixed so that it will not pivot about the x axis. The other three bearings are free to pivot about the x axis.

NOTE 3—Bearing cylinders are held in place by low-stiffness springs, rubber bands, or magnets.

FIG. 3 Schematics of Two Fully Articulating Four-Point Fixtures Suitable Either for Twisted or Uneven Specimens, or for Flat and Parallel Specimens

TABLE 3 Specimen Size

Configuration	Width (b), mm	Depth (d), mm	Length (L ₇), min, mm
A	2.0	1.5	25
B	4.0	3.0	45
C	8.0	6.0	90

7.2.4.8 The four long edges of each B-sized test specimen shall be uniformly chamfered at 45°, a distance of 0.12 ± 0.03 mm as shown in Fig. 4. They can alternatively be rounded with a radius of 0.15 ± 0.05 mm. Edge finishing must be comparable to that applied to the test specimen surfaces. In particular, the direction of machining shall be parallel to the test specimen long axis. If chamfers or rounds are larger than the tolerance allows, then corrections shall be made to the stress calculation in accordance with Annex A2. Smaller chamfer or rounded edge sizes are recommended for A-sized

bars. Larger chamfers or rounded edges may be used with C-test specimens. Consult Annex A2 for guidance and whether corrections for flexural strength are necessary. No chipping is allowed. Up to 50× magnification may be used to verify this. Alternatively, if a test specimen can be prepared with an edge that is free of machining damage, then a chamfer is not required.

7.2.4.9 Very deep skip marks or very deep single striations (which may occur due to a poor quality grinding wheel or due to a failure to true, dress, or balance a wheel) are not acceptable.

7.2.5 Handling Precautions and Scratch Inspection—Exercise care in storing and handling of specimens to avoid the introduction of random and severe flaws, such as might occur if specimens were allowed to impact or scratch each other. If required by the user, inspect some or all of the surfaces as

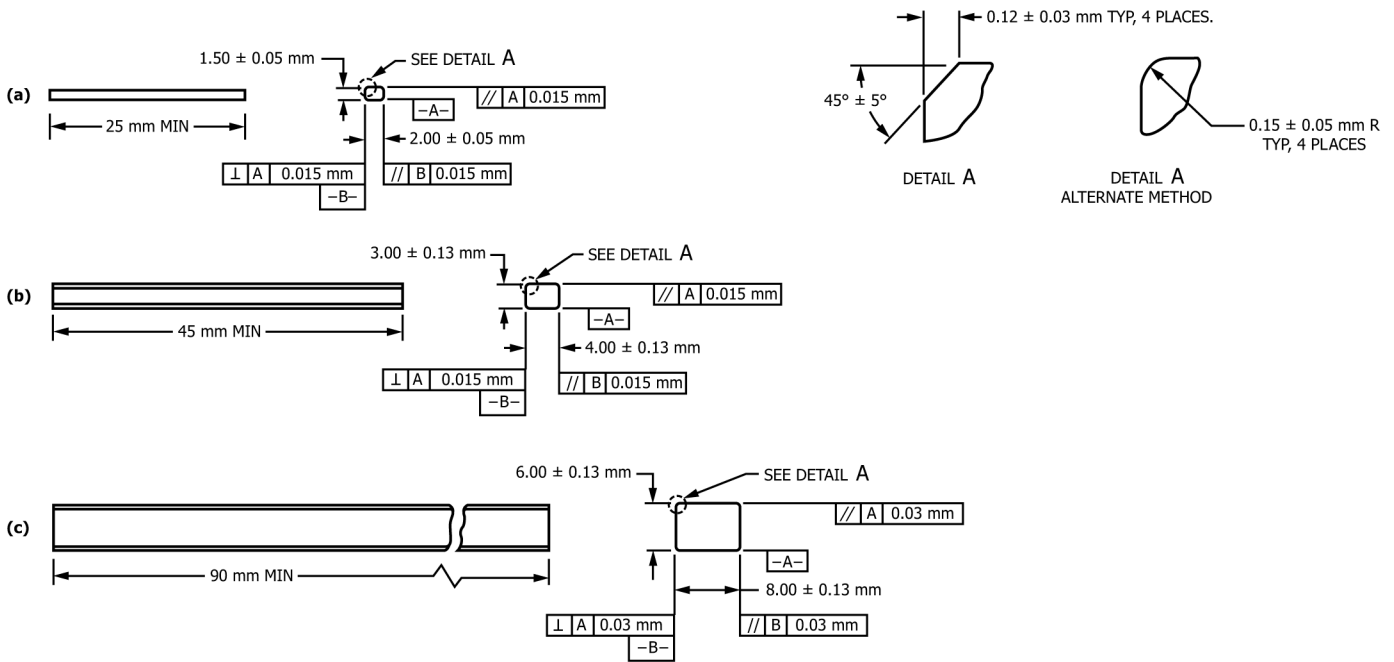

FIG. 4 Standard Test Specimens

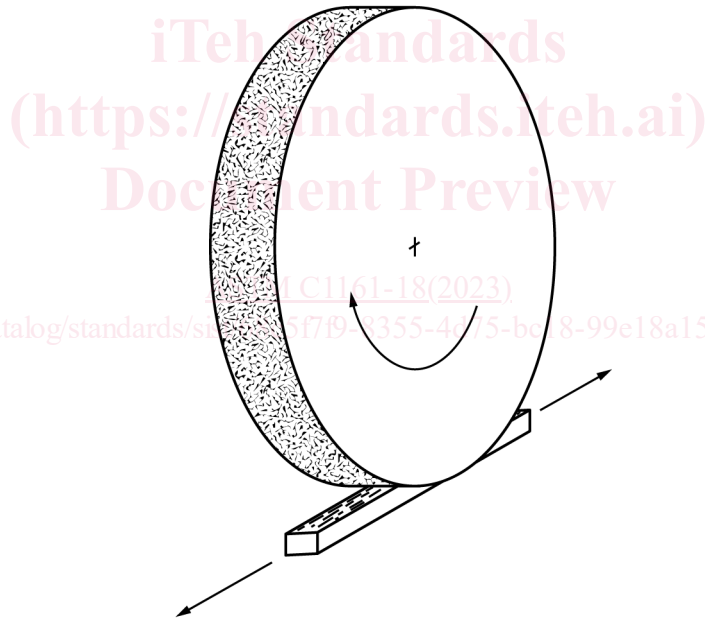

FIG. 5 Surface Grinding Parallel to the Specimen Longitudinal Axis

required for evidence of grinding chatter, scratches, or other extraneous damage. A 5× to 10× hand loupe or a low-power stereo binocular microscope may be used to aid the examination. Mark the scratched surface with a pencil or permanent marker if scratches or extraneous damage are detected. If such damage is detected, then the damaged surface should not be placed in tension, but instead on the compression mode of loading when the specimen is inserted into the test fixtures.

NOTE 10—Damage or scratches may be introduced by handling or mounting problems. Scratches are sometimes caused by loose abrasive grit.

7.3 *Number of Specimens*—A minimum of ten specimens shall be required for the purpose of estimating the mean. A minimum of 30 shall be necessary if estimates regarding the form of the strength distribution are to be reported (for example, a Weibull modulus). The number of specimens required by this test method has been established with the intent of determining not only reasonable confidence limits on strength distribution parameters, but also to help discern multiple-flaw population distributions. More than 30 specimens are recommended if multiple-flaw populations are present.