



Designation: **E3343/E3343M – 22 E3343/E3343M – 23**

Test Methods for Nonballistic-resistant Helmets Worn by Law Enforcement and Corrections¹

This standard is issued under the fixed designation E3343/E3343M; the number immediately following the designation indicates the year of original adoption or, in the case of revision, the year of last revision. A number in parentheses indicates the year of last reappraisal. A superscript epsilon (ϵ) indicates an editorial change since the last revision or reappraisal.

1. Scope

1.1 This standard provides nonballistic test methods and conditioning procedures for assessing head protection (that is, helmet and face shield) worn by law enforcement and corrections officers.

1.1.1 Conditioning procedures are included to assess durability in terms of resistance to chemicals and cleaning products, extreme temperatures, weathering, and absorption of liquids.

1.1.2 Test methods are included to assess the protective performance against hazards including impact/bump, projectiles (other than bullets), flame, and liquids.

1.1.3 Test methods are included to assess safety and ergonomic aspects of retention system strength, stability of the helmet on the wearer's head, corrosion resistance, and face shield visual acuity, field of view, scratch resistance, and anti-mist properties.

NOTE 1—These test methods reference published standards from ASTM International and other standards developing organizations. Appendix XI contains a summary of test methods included in this standard, along with the source and purpose for each.

1.2 These test methods do not address eye protection other than face shields that are attached to the helmet.

1.3 It is anticipated that these test methods will be referenced by suppliers, certifiers, purchasers, or other users to meet their specific needs. Those users will specify, in other standards and specifications, which test methods and conditioning procedures are applicable and will specify any performance categories or levels.

1.3.1 If there is a discrepancy between these test methods and a user-supplied document, the user-supplied document shall take precedence.

1.4 In these test methods, “other standards and specifications” and “unless specified elsewhere” refer to documents (for example, military standards, purchase specifications) that require the use of these test methods. Purchasers and other users are responsible for the “other standards and specifications” and for specifying any requirements that supersede those of these test methods.

1.5 *Units*—The values stated in either SI units or inch-pound units are to be regarded separately as standard. The values stated in each system are not necessarily exact equivalents; therefore, to ensure conformance with the standard, each system shall be used independently of the other, and values from the two systems shall not be combined.

¹ These test methods are under the jurisdiction of ASTM Committee E54 on Homeland Security Applications and is the direct responsibility of Subcommittee E54.04 on Personal Protective Equipment (PPE) Public Safety Equipment.

Current edition approved March 1, 2022; Feb. 1, 2023. Published April 2022; March 2023. Originally approved in 2022. Last previous edition approved in 2022 as E3343/E3343M DOI: 10.1520/E3343-E3343M-22; – 22. DOI: 10.1520/E3343_E3343M-23.

1.6 This standard does not purport to address all of the safety concerns, if any, associated with its use. It is the responsibility of the user of this standard to establish appropriate safety, health, and environmental practices and determine the applicability of regulatory limitations prior to use.

1.7 This international standard was developed in accordance with internationally recognized principles on standardization established in the Decision on Principles for the Development of International Standards, Guides and Recommendations issued by the World Trade Organization Technical Barriers to Trade (TBT) Committee.

2. Referenced Documents

2.1 ASTM Standards:²

B117 Practice for Operating Salt Spray (Fog) Apparatus

E2771 Terminology for Homeland Security Applications

E3004 Specification for Preparation and Verification of Clay Blocks Used in Ballistic-Resistance Testing of Torso Body Armor

F803 Specification for Eye Protectors for Selected Sports

F1446 Test Methods for Equipment and Procedures Used in Evaluating the Performance Characteristics of Protective Headgear

F1587 Specification for Head and Face Protective Equipment for Ice Hockey Goaltenders

F2220 Specification for Headforms

2.2 AATCC Standards:³

AATCC Test Method 169 Weather Resistance of Textiles: Xenon Lamp Exposure

2.3 ANSI Standards:⁴

ANSI Z26.1 Safety Glazing Materials for Glazing Motor Vehicles and Motor Vehicle Equipment Operating on Land Highways - Safety Standard

2.4 CSA Standards:⁵

CAN/CSA Z611-02 Riot Helmets and Face shield Protection

CSA Z262.6-14 Specifications for Facially Featured Headforms

2.5 ISO/IEC Standards:⁶

ISO/IEC 17025 General Requirements for the Competence of Testing and Calibration Laboratories

2.6 NFPA Standards:⁷

NFPA 1981 Standard on Open-circuit Self-contained Breathing Apparatus (SCBA) for Emergency Services, 2019

2.7 NIJ Standards:⁸

NIJ 0104.02 Standard for Riot Helmets and Face Shields

NIJ 0115.00 Stab Resistance of Personal Body Armor **E3343/E3343M-23**

2.8 SAE Standards:⁹

SAE Recommended Practice J2111/1_201403 Instrumentation for Impact Test - Part 1 - Electronic Instrumentation, 2014

2.9 Other Documents:

Home Office Scientific Development Branch (PSDB) 21/04 PSDB Protective Headwear Standard for UK Police (2004), Public Order Helmet¹⁰

3. Terminology

3.1 Definitions:

3.1.1 *basic plane, n*—an anatomical plane (Frankfort horizontal plane) that includes the superior rim of the external auditory meatus (upper edge of the external openings of the ear) and the inferior margin of the orbit (the lowest point of the floor of the eye socket) (see Fig. 1 and Fig. 2).

(Test Methods F1446)

² For referenced ASTM standards, visit the ASTM website, www.astm.org, or contact ASTM Customer Service at service@astm.org. For *Annual Book of ASTM Standards* volume information, refer to the standard's Document Summary page on the ASTM website.

³ Available from American Association of Textile Chemists and Colorists (AATCC), P.O. Box 12215, Research Triangle Park, NC 27709-2215, <http://www.aatcc.org>.

⁴ Available from American National Standards Institute (ANSI), 25 W. 43rd St., 4th Floor, New York, NY 10036, <http://www.ansi.org>.

⁵ Available from Canadian Standards Association (CSA), 178 Rexdale Blvd., Toronto, ON M9W 1R3, Canada, <http://www.csagroup.org>.

⁶ Available from International Organization for Standardization (ISO), ISO Central Secretariat, Chemin de Blandonnet 8, CP 401, 1214 Vernier, Geneva, Switzerland, <https://www.iso.org>.

⁷ Available from National Fire Protection Association (NFPA), 1 Batterymarch Park, Quincy, MA 02169-7471, <http://www.nfpa.org>.

⁸ Available from National Institute of Justice (NIJ), 810 7th St., NW, Washington, DC 20531, <http://nij.gov>.

⁹ Available from SAE International (SAE), 400 Commonwealth Dr., Warrendale, PA 15096, <http://www.sae.org>.

¹⁰ Available from Home Office Direct Communications Unit, 2 Marsham Street, London, SW1P 4DF, United Kingdom, <http://www.gov.uk/government/organisations/home-office>.

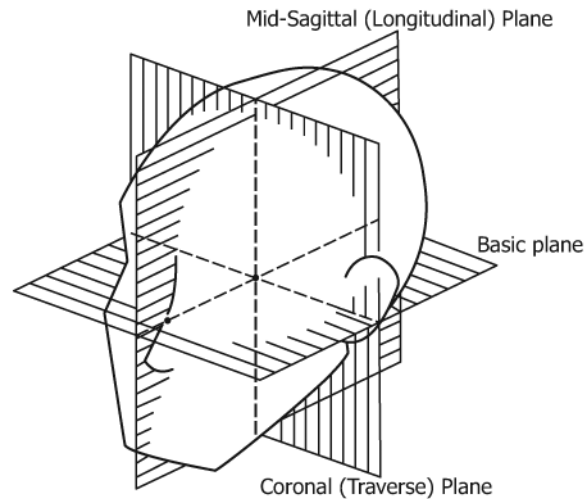

FIG. 1 Anatomical Planes

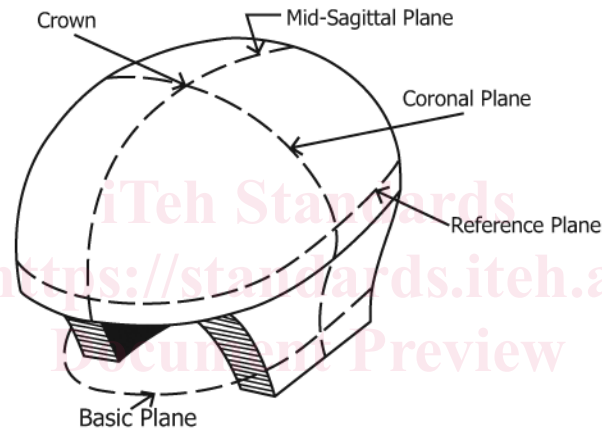

FIG. 2 Headform with Locations for Anatomical Planes

<https://standards.iteh.ai/catalog/standards/sist/91e15bd4-eb12-4764-9bc4-46889d2a624c/astm-e3343-e3343m-23>

3.1.2 *conditioning, n*—a process that exposes an item, prior to testing, to a specified controlled environment or physical stresses, or both. **(Terminology E2771)**

3.1.3 *controlled ambient, n*—conditions with temperature of $20\text{ }^{\circ}\text{C} \pm 5.5\text{ }^{\circ}\text{C}$ [$68\text{ }^{\circ}\text{F} \pm 10\text{ }^{\circ}\text{F}$] and $50\text{ } \% \pm 20\text{ } \%$ relative humidity (RH). **(Terminology E2771)**

3.1.4 *coronal plane, n*—an anatomical plane perpendicular to both the basic and midsagittal planes and passing through the superior rims of the right and left auditory meatuses; the transverse plane corresponds to the coronal plane (see Fig. 1 and Fig. 2). **(Test Methods F1446)**

3.1.5 *fair hit, n*—a test threat impact (on a test item) that meets all specified requirements in a particular test method. **(Terminology E2771)**

3.1.6 *field of vision, n*—angle of vision as measured on the reference headform (upward, downward, and peripheral). **(Test Methods F1446)**

3.1.7 *helmet, n*—a protective device worn on the head in an effort to reduce or minimize injury to that portion of the head that is within an area above the reference plane (as defined in the individual performance standards). **(Test Methods F1446)**

3.1.8 *helmet position index (HPI), n*—the vertical distance from the brow of the helmet to the basic plane, when the helmet is placed on a reference headform; the manufacturer shall specify the size of the headform and the vertical distance. **(Test Methods F1446)**

3.1.9 *mid-sagittal plane, n*—an anatomical plane perpendicular to the basic plane and containing the midpoint of the line connecting the notches of the right and left inferior orbital ridges and the midpoint of the line connecting the superior rims of the right and left external auditory meatus; the longitudinal plane corresponds to the midsagittal plane (see Fig. 1 and Fig. 2). **(Test Methods F1446)**

3.1.10 *modular elastomer programmer (MEP), n*—a cylindrical-shaped pad used as the impact surface for the spherical impactor. **(Test Methods F1446)**

3.1.11 *reference plane, n*—a plane marked on the headforms at a specified distance above and parallel to the basic plane (see Fig. 2). **(Test Methods F1446)**

3.1.12 *retention system, n*—the complete assembly that secures the helmet, in a stable position, on the wearer’s head. **(Test Methods F1446)**

3.1.13 *test area, n*—the area of the helmet on or above a specified reference plane, subject to impact or penetration testing. **(Test Methods F1446)**

3.1.14 *test item, n*—a single article intended for testing. **(Terminology E2771)**

4. Significance and Use

4.1 The purpose of these test methods is to provide reliable and repeatable nonballistic test methods and conditioning procedures for the evaluation of head protection used in law enforcement and corrections applications.

4.2 It is anticipated that these test methods will be referenced by certifiers, purchasers, or other users in order to meet their specific needs. Those users will specify which test methods and conditioning procedures are applicable, and will specify any performance categories or levels.

4.3 These test methods include some procedures and references to other standards to ensure that relevant properties are addressed.

5. Hazards

5.1 The tests described in these test methods have inherent hazards. It is the responsibility of the testing laboratory to ensure adequate safeguards for personnel and property when conducting these tests.

6. Test Item Requirements

6.1 The test items shall be either to be used (1) for complete helmets with retention and suspension systems, face shields, and hardware; each test method shall be specified in the test method. (2) helmet shells; (3) face shields; or (4) coupons representing face shields. For some tests, the helmet shell alone is the test item while for other tests the test item is the helmet shell with its hardware, suspension system, and retention system.

6.1.1 The face shield shall always be attached to the helmet shell during face shield testing and shall be in the deployed position and locked or secured with supplied hardware, where available.

6.2 There shall be no variation in construction details between individual test items or between any test item and the supplier’s documentation for a given model.

7. Conditioning Requirements

7.1 Perform a visual inspection of test items both prior to and after conditioning, and record observations and changes in physical features.

7.2 When conditioning is required prior to a performance test involving impact to test items, unless specified elsewhere, the following requirements apply for each type of conditioning:

7.2.1 Once testing begins, the test item shall not be out of conditioning for more than 5 min at a time and then shall be returned to conditioning for at least 15 min. There is no limit to the number of times the test item can be returned to conditioning over the test series.

NOTE 2—Each test, taking up to 5 min, is followed by at least 15 min of conditioning.

8. Temperature and Humidity Conditioning Procedures

8.1 *Environmental Chamber:*

8.1.1 The environmental chamber shall be capable of achieving and maintaining the required temperature and humidity within the specified tolerances for the duration of the conditioning procedure.

8.1.2 The monitoring equipment shall include measurement and recording device(s), independent from the chamber controllers.

8.1.3 The monitoring equipment shall provide and allow documentation of temperature and relative humidity measurements inside the chamber.

8.2 *Controlled Ambient Conditioning:*

8.2.1 Subject each test item to controlled ambient conditions of $20.0\text{ }^{\circ}\text{C} \pm 5.5\text{ }^{\circ}\text{C}$ [$68\text{ }^{\circ}\text{F} \pm 10\text{ }^{\circ}\text{F}$] and $50\% \pm 20\%$ relative humidity (RH) for at least 24 h.

8.3 *Extreme Heat Conditioning:*

8.3.1 Subject each test item to extreme heat conditioning for between 24 h and 48 h at $71\text{ }^{\circ}\text{C} \pm 5.5\text{ }^{\circ}\text{C}$ [$160\text{ }^{\circ}\text{F} \pm 10\text{ }^{\circ}\text{F}$] and relative humidity of $50\% \pm 20\%$ in a conditioning chamber.

8.4 *Extreme Cold Conditioning:*

8.4.1 Subject each test item to extreme cold conditioning for between 24 h and 48 h at $-51\text{ }^{\circ}\text{C} \pm 5.5\text{ }^{\circ}\text{C}$ [$-60\text{ }^{\circ}\text{F} \pm 10\text{ }^{\circ}\text{F}$] in a conditioning chamber.

9. Artificial Weathering Conditioning Procedure

9.1 *Equipment:*

9.1.1 The equipment shall be as described in AATCC Test Method 169.

9.2 Weathering of test items shall be performed in accordance with AATCC Test Method 169 with the modifications listed below:

9.2.1 The test apparatus shall be a xenon weatherometer with reflective panels.

9.2.2 The test apparatus shall be equipped with an automatic light monitor and shall be capable of automatically controlling irradiance, temperature, and humidity. The apparatus shall be maintained in accordance with manufacturer recommendations.

9.2.3 The weathering cycle shall be a total of 180 min, consisting of the following in order: 40 min of light, 20 min of light with

water spray on the test item, 60 min of light, and 60 min of darkness. The cycle shall be repeated until the total energy exposure is equal to 100 kJ/m², and the weathering cycle shall be terminated at that point.

9.2.4 The spectral irradiance level shall be 0.55 W/m²/nm ± 0.01 W/m²/nm bandpass at 340 nm.

9.2.5 The glass filter combination shall be quartz inner filter and a borosilicate type “S” outer filter.

9.2.6 The temperatures and RH shall be as specified in **Table 1**.

9.3 After the required exposure period, the test items shall be removed from the apparatus.

9.4 Any area of the helmet shell may be tested due to the light reflecting off the panels used in the weatherometer.

10. Chemical Exposure Conditioning

10.1 *Equipment and Materials:*

10.1.1 The chemicals to be used shall be specified by the user of these test methods.

10.2 The entire exterior of the test item (helmet shell and face shield) shall be treated with at least 25 mL [0.85 oz] of the chemical. The chemical shall remain on the surface for at least 30 s.

10.3 The test item shall be wiped with a clean cloth to remove excess chemical.

10.4 Subsequent performance tests on the test item shall not begin within 24 h of the chemical exposure

11. Conditioning by Submersion in Water

11.1 *Equipment and Materials:*

11.1.1 Equipment shall consist of a fluid container of sufficient size to allow at least one test item of the largest size to be fully submersed.

11.1.2 Appropriate range weight scale capable of measuring to the nearest 0.5 g [0.001 lb] shall be used for weighing test items.

11.1.3 The water may be either plain water or salt water.

11.1.3.1 The plain water shall be clean and shall be either potable tap or demineralized water.

11.1.3.2 The salt water solution shall consist of 3 % by weight sodium chloride and 0.5 % by weight magnesium chloride, and be adjusted to a pH of 8.2.

11.1.3.3 The water shall be replaced anytime there are visible impurities in the water.

TABLE 1 Temperature and Humidity for Weathering Procedure

	Dark Cycle	Light Cycle
Black Panel	38 °C ± 3 °C [100 °F ± 5 °F]	77 °C ± 3 °C [171 °F ± 5 °F]
Conditioning Water	40 °C ± 3 °C [104 °F ± 5 °F]	53 °C ± 3 °C [127 °F ± 5 °F]
Wet Bulb Depression	0 °C ± 3 °C [32 °F ± 5 °F] RH ≥ 95 %	10 °C ± 3 °C [50 °F ± 5 °F] RH = 50 % ± 5 % (This does not apply to light cycle with water spray.)

11.1.4 A “20-lb weight” may be used to prevent the test item from floating while immersed.

11.2 *Test Items:*

11.2.1 Each test item shall be a complete helmet, including the helmet shell, face shield, and retention and suspension systems.

11.2.2 Each test item shall be conditioned according to 8.2, unless specified elsewhere.

11.3 *Procedure:*

11.3.1 Weigh each test item to the nearest 1 g [0.002 lb] prior to immersion.

11.3.2 Immerse the test item(s), with crown pointed down, in water at a temperature between 16 °C and 26 °C [60 °F and 80 °F]. Each test item is required to be completely submerged, with the uppermost part approximately 15 cm [6 in.] beneath the surface of the water.

11.3.2.1 Test items shall not be stacked atop each other during immersion but may be placed side-by-side.

11.3.2.2 If necessary to prevent floating while in fluid, place a weight on each test item.

11.3.3 The test item(s) shall be immersed for 3 h to 4 h.

11.3.3.1 Following immersion, allow the test item to drain crown up for 5 min ± 10 s to shed non-absorbed water before final weighing. Do not wipe excess moisture from the test item.

11.3.3.2 Promptly weigh the test item to the nearest 1 g [0.002 lb].

11.3.3.3 Examine the test item for softening, peeling, blistering, cracking, or delamination.

11.3.3.4 Any subsequent performance test shall be completed within 2 h.

11.4 *Documentation:*

11.4.1 The before and after weights, any weight gain, and observations of degradation shall be documented.

12. Performance Testing Requirements for Impact Tests

12.1 *Fair Hit Requirements:*

12.1.1 Each impact on a test item shall be within 12.7 mm [0.5 in.] of the marked impact location.

12.1.2 Each impact on a test item shall be at least 25 mm [1.0 in.] from any attachment points, unless the test method specifies impacting attachment points.

13. Helmet Impact Attenuation Test Method

13.1 *Equipment and Materials:*

13.1.1 *Headforms:*

13.1.1.1 Headforms shall be Department of Transportation (DOT) MAG.K1A.

NOTE 3—The reference plane is typically marked on DOT headforms.

13.1.1.2 One of the following four headform sizes shall be used: A, B, C, or D.

13.1.1.3 The headform shall be appropriately sized for the test item and include mountings for accelerometers situated at the headform center of gravity.

13.1.2 *Free Fall Test Setup:*

13.1.2.1 The test setup shall consist of a guided free fall system for a drop assembly and shall have a fixture for supporting the headform and test item.

13.1.2.2 The headform or the fixture supporting the headform shall have an attachment point for the helmet chin strap that, when tightened, prevents movement of the helmet on the headform. See Fig. 3 for an example headform with chin strap attachment point.

13.1.2.3 The drop assembly shall consist of the headform, the accelerometer, and the supporting fixture. The center of mass of the drop assembly shall lie within a cone with its axis vertical and forming a 10° included angle with the vertex at the point of impact (Test Methods F1446).

13.1.2.4 The supporting fixture shall not affect the measurement of acceleration at the center of gravity of the headform.

13.1.2.5 An example test setup is shown in Fig. 4 (Specification F1587).

13.1.3 *Velocity Measuring System:*

13.1.3.1 A velocity measuring system shall be used and shall be capable of measuring the velocity of the test item within 50 mm [2 in.] of the top of the test anvil with an accuracy of ±0.1 m/s [0.3 ft/s].

13.1.4 *Accelerometer (Test Methods F1446):*

13.1.4.1 A uni-axial accelerometer capable of withstanding a shock of at least 9810 m/s² [1000 g] in the headform, with a minimum measuring range of 3923 m/s² [0 g to 400 g] acceleration with an accuracy of ±5 % shall be used.

13.1.4.2 The accelerometer data channel, including all instrumentation which may alter the frequency content of the test data and all recoding and analysis procedures, shall comply with SAE Recommended Practice J211/1_201403 requirements for channel class 1000. The minimum data sampling rate shall be 10 kHz.

13.1.5 *Instrument System Check Equipment (Test Methods F1446):*

13.1.5.1 The impact surface for the instrument system check shall be a flat modular elastomer programmer (MEP), 152 mm [6 in.] in diameter and 25 mm [1 in.] in thickness. The MEP shall have a durometer of 60 ± 2 Shore “A.” It is affixed to the top surface of a flat, 6.35 mm [0.25-in.] thick aluminum plate.

13.1.5.2 A spherical impactor made of low resonance material (for example, magnesium), aluminum alloy, or stainless steel that



FIG. 3 Example Headform with Chin Strap Attachment Point

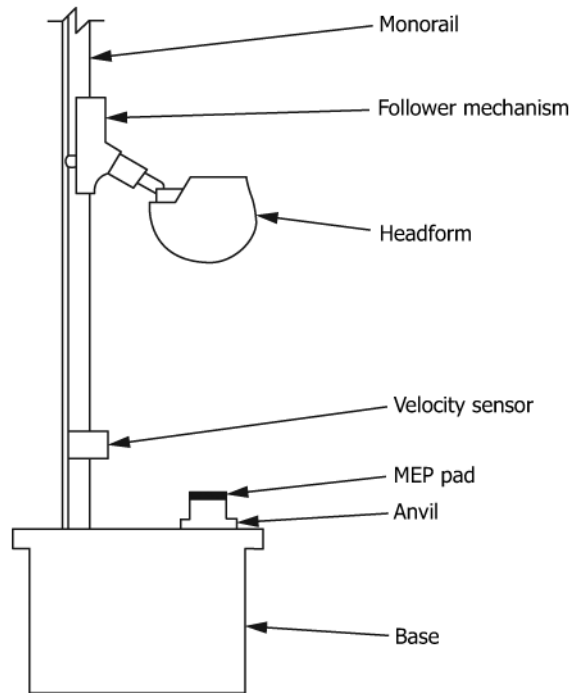

FIG. 4 Example Helmet Impact Attenuation Test Setup

iTeh Standards

couples mechanically with the ball arm connector of the drop assembly shall be used in place of the headform. When mounted, the device presents a spherically machined impact face with a radius of 73 mm [3 in.] on its bottom surface. All radii from the center of curvature of the impact face to its outer edge shall form angles of no less than 40° with the downward vertical axis. The center of curvature shall be within 5 mm [0.2 in.] of the vertical axis drawn through the center of the ball arm.

13.1.6 Test Anvils (Test Methods F1446):

13.1.6.1 Five test anvils may be used:

(1) *Flat Anvil*—The flat anvil shall have a flat surface of a minimum 125 mm [5-in.] diameter circle and shall be at least 24 mm [1-in.] thick (see Fig. 5). The anvil shall be made from B01 tool steel with a hardness level of 54 to 56 HRC.

(2) *Triangular Anvil*—The triangular anvil shall have a $90^\circ \pm 0.5^\circ$ striking edge with a 0.5 mm to 1.5 mm [0.02-in. to 0.06-in.] radius. The height shall be not less than 50 mm [2 in.], and the length shall be not less than 200 mm [8 in.] (see Fig. 6). The anvil shall be made from B01 tool steel with a hardness level of 54 to 56 HRC.

(3) *Brick Corner Anvil*—The brick corner anvil shall have dimensions as shown in Fig. 7 and shall be made from B01 tool steel with a hardness level of 54 to 56 HRC.

(4) *Cylindrical Anvil*—The cylindrical anvil shall have dimensions as shown in Fig. 8 and shall be made from B01 tool steel with a hardness level of 54 to 56 HRC.

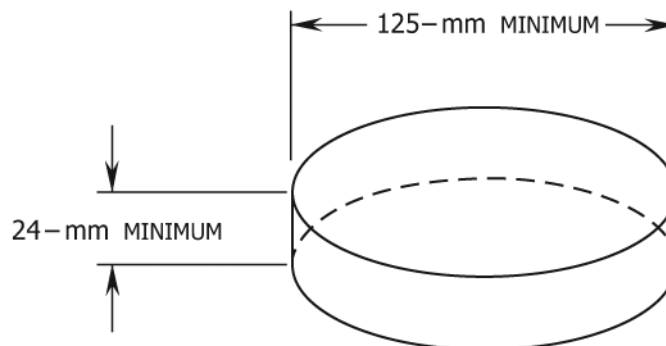

FIG. 5 Flat Anvil

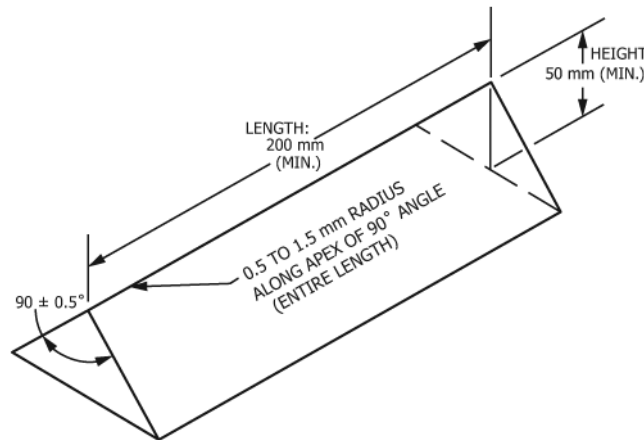

FIG. 6 Triangular Anvil

(5) *Hemispherical Anvil*—The hemispherical anvil shall have a spherical surface with a radius of $48 \text{ mm} \pm 1 \text{ mm}$ [$1.9 \text{ in.} \pm 0.04 \text{ in.}$]. The spherical surface constitutes one half of the surface of a sphere. The anvil shall be made from B01 tool steel with a hardness level of 54 to 56 HRC.

13.1.6.2 The test anvil shall be mounted on a solid block having a minimum mass of 500 kg [1100 lb].

13.1.6.3 The triangular anvil shall be positioned so that its long axis is perpendicular to the monorail that supports the headform, and the brick corner anvil shall be positioned so that a side edge faces the monorail. See Fig. 9.

13.2 Test Items:

13.2.1 The user of these test methods shall specify the number of test items.

13.2.1.1 Unless specified elsewhere, two test items of each available helmet size are required.

13.2.2 Each test item shall be a complete helmet, including the helmet shell, retention system, and suspension system. If a face shield and nape guard are present, they shall be removed from the helmet before impact testing.

13.2.3 Each test item shall be marked with the impact locations.

13.2.4 The user of these test methods shall specify any conditioning procedures to be performed prior to testing.

13.2.4.1 Unless specified elsewhere, one of each size test item shall be conditioned according to 8.3, and the other of each size test item shall be conditioned according to 8.4.

13.3 Instrument System Check (Test Methods F1446):

13.3.1 The instrument system shall be checked before and after each series of tests by dropping the spherical impactor onto the MEP pad at an impact velocity of 5.44 m/s [18 ft/s] ($\pm 2 \%$).

13.3.2 Impact velocity shall be measured during the last 50 mm [2.0 in.] of free fall for each test.

13.3.3 The weight of the drop assembly (which is the combined weight of the instrumented spherical impactor and supporting assembly) for the drop test shall be $5 \text{ kg} \pm 0.1 \text{ kg}$ [$11 \text{ lb} \pm 0.2 \text{ lb}$].

13.3.4 Three such impacts, at intervals of 75 s to 90 s, shall be performed before and after each series of tests.

13.3.5 The peak acceleration obtained during impact shall be $3815 \text{ m/s}^2 \pm 78 \text{ m/s}^2$ [$389 \text{ g} \pm 8 \text{ g}$].

13.3.5.1 If any of the three pre-test drops do not meet the peak acceleration tolerance, checks of the mechanical condition of the

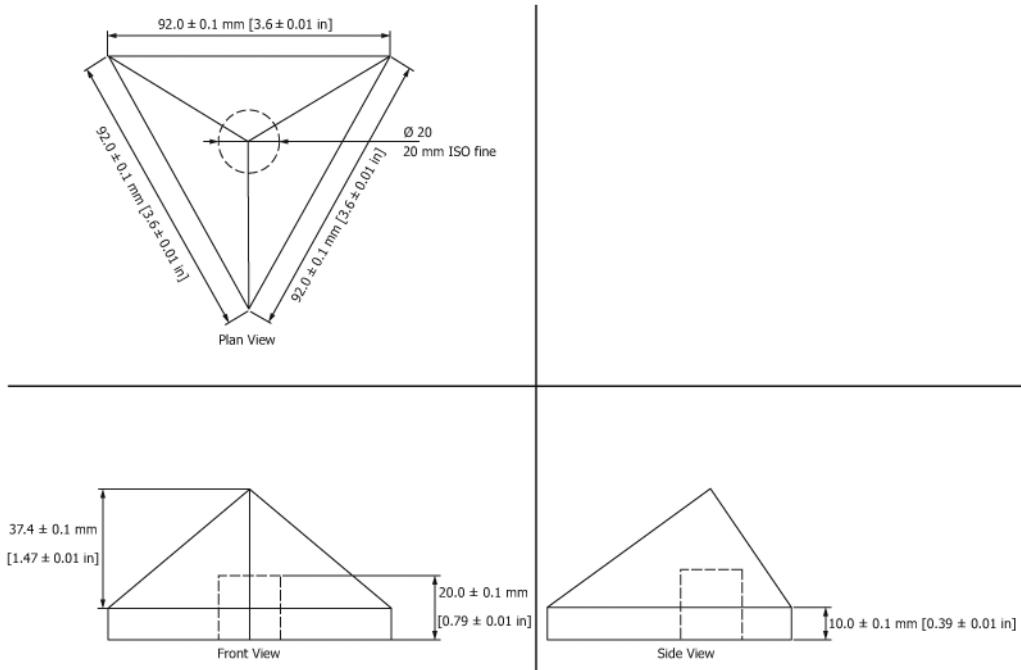

FIG. 7 Brick Corner Anvil (Details taken from PSDB 21/04)

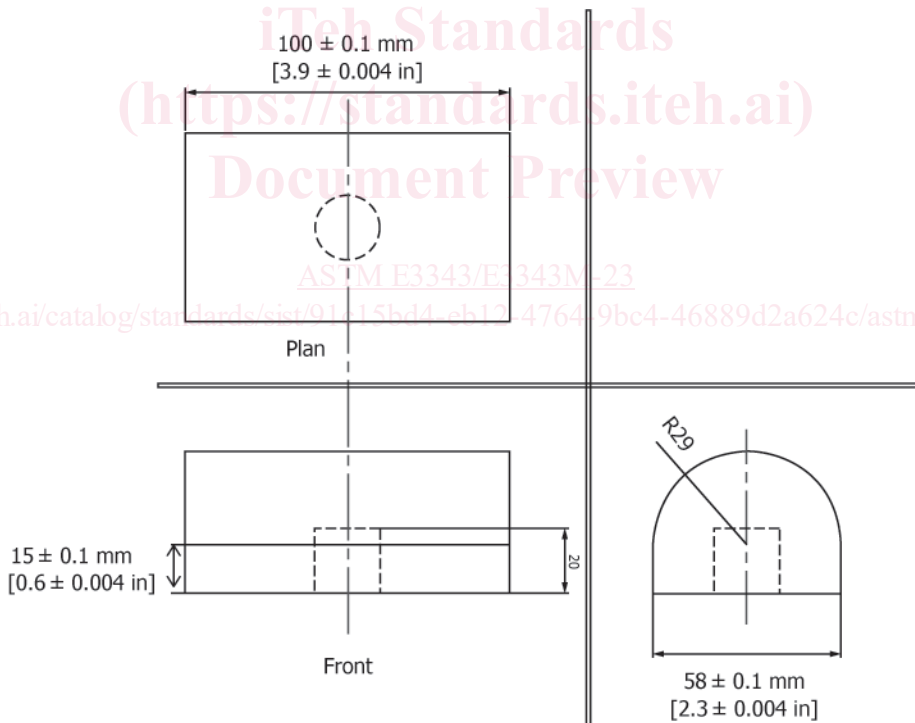

FIG. 8 Cylindrical Anvil (Details taken from PSDB 21/04)

drop system, the calibration of the instruments, and transducers are required, and the three drops shall be repeated. This process shall be continued until all three drops are within tolerance.

13.3.5.2 If the average peak acceleration obtained in the three post-test drops differs by more than 5 % from the average peak acceleration obtained in the pre-test drops, this shall be documented. The test shall be considered invalid and shall be repeated.

13.4 Test Requirements:

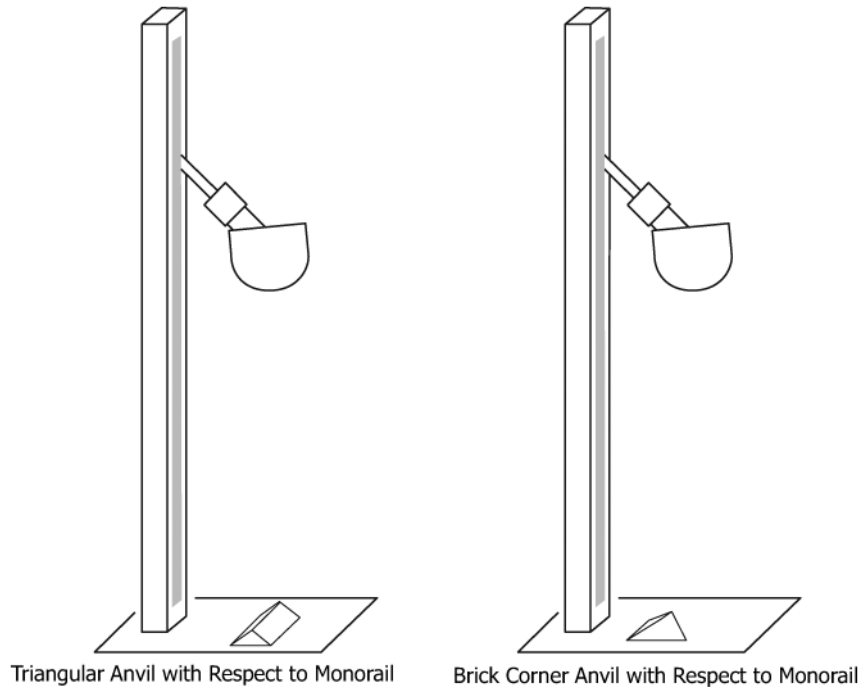

FIG. 9 Test Anvils Positioned Relative to Monorail in Test Setup

iTeh Standards

(<https://standards.itihq.com>)
Document Preview

13.4.1 The minimum center-to-center impact spacing shall be half the distance from crown impact to side impact, unless multiple impacts in a single location are required.

13.4.2 Each test item shall be impacted in each of five locations: front, side (left or right), back, crown, and a boss location selected by the testing laboratory.

13.4.2.1 The front impact location shall be on the front within 50 mm [2 in.] on either side of the midsagittal plane and within 50 mm to 100 mm [2 in. to 4 in.] from the helmet front edge or crease forming a brim, whichever is higher, and ensuring that the shell is only impacted in a single location.

13.4.2.2 The side impact location shall be on the side 50 mm [2 in.] to either side of the coronal plane. The impact shall be within 50 mm to 100 mm [2 in. to 4 in.] of the reference plane, ensuring that the shell is only impacted in a single location.

13.4.2.3 The rear impact location shall be at the rear within 50 mm [2 in.] on either side of the midsagittal plane and within 50 mm to 100 mm [2 in. to 4 in.] above the reference plane, ensuring that the shell is only impacted in a single location.

13.4.2.4 The crown impact location shall be at a point within 25 mm [1 in.] of the intersection of the midsagittal plane and the coronal plane.

13.4.3 The boss impact location shall be on the opposite side of side impact location of 13.4.2.2, approximately 45° from the coronal plane (towards front or back), and within 50 mm to 100 mm [2 in. to 4 in.] above the reference plane, ensuring that the shell is only impacted in a single location.

13.4.4 Testing shall begin promptly after the test item is removed from conditioning.

13.5 Procedure:

13.5.1 Place the test item on the appropriately sized headform so that it is securely fastened and adjusted according to the manufacturer instructions and helmet positioning index (HPI).

13.5.2 Position the test item in the test setup such that the area to be tested is directly in line with the selected test anvil.