



Designation: **D889 – 13 (Reapproved 2017) D889 – 23**

Standard Test Method for Volatile Oil in Rosin¹

This standard is issued under the fixed designation D889; the number immediately following the designation indicates the year of original adoption or, in the case of revision, the year of last revision. A number in parentheses indicates the year of last reapproval. A superscript epsilon (ϵ) indicates an editorial change since the last revision or reapproval.

1. Scope

1.1 This test method covers the determination of the volatile oil content of rosin or similar material. The oil may consist of naturally occurring terpene oil, such as heavy fractions of turpentine, resulting from incomplete distillation in the processing of the rosin, or of foreign nonterpene oil resulting from incomplete removal of mineral or coal-tar solvent used to extract the rosin from wood or still wastes. In certain cases the volatile oil could consist of decarboxylated rosin formed during the processing of the rosin.

1.2 The values stated in SI units are to be regarded as standard. No other units of measurement are included in this standard.

1.3 *This standard does not purport to address all of the safety concerns, if any, associated with its use. It is the responsibility of the user of this standard to establish appropriate safety, health, and environmental practices and determine the applicability of regulatory limitations prior to use.*

1.4 *This international standard was developed in accordance with internationally recognized principles on standardization established in the Decision on Principles for the Development of International Standards, Guides and Recommendations issued by the World Trade Organization Technical Barriers to Trade (TBT) Committee.*

2. Referenced Documents

- 2.1 *ASTM Standards:*²
- D233 Test Methods of Sampling and Testing Turpentine
 - E1 Specification for ASTM Liquid-in-Glass Thermometers

3. Significance and Use

3.1 Rosin and similar materials such as rosin derivatives often contain volatile material derived from the raw material used or formed as a result of the processing of the rosin. This volatile material can have a significant effect on the physical and chemical properties of the rosin and so a standard method for its determination is required.

4. Apparatus

4.1 *Flask, 500-mL* 500 mL round-bottom having a thermometer well and a 24/40 standard-taper ground joint for connection with the trap (see Fig. 1).

¹ This test method is under the jurisdiction of ASTM Committee D01 on Paint and Related Coatings, Materials, and Applications and is the direct responsibility of Subcommittee D01.34 on Pine Chemicals and Hydrocarbon Resins.

Current edition approved Dec. 1, 2017; Feb. 1, 2023. Published December 2017; March 2023. Originally approved in 1946. Last previous edition approved in 2013 as D889 – 13; D889 – 13 (2017). DOI: 10.1520/D0889-13R17.10.1520/D0889-23.

² For referenced ASTM standards, visit the ASTM website, www.astm.org, or contact ASTM Customer Service at service@astm.org. For *Annual Book of ASTM Standards* volume information, refer to the standard's Document Summary page on the ASTM website.

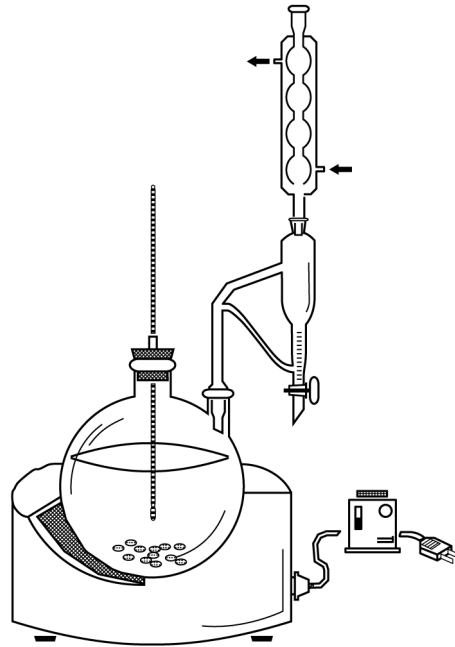

FIG. 1 Flask

4.2 *Trap* (Fig. 2), designed so as to overcome the tendency for droplets of oil to remain below the surface of the water, due to the greater viscosity of the volatile oils recovered from rosin, and thus be returned to the flask (Note 1). The trap shall be fitted with 24/40 standard-taper ground joints to provide tight connections with the flask and condenser, in order to avoid vapor loss.

NOTE 1—This trap is a modification of the original Clevenger trap used to recover oils lighter than water. In that trap the oil and water condensate drop directly into the graduated part of the trap. Due to the viscous character, density, and surface tension of the oils recovered from rosin, cylindrical columns of oil were formed below the surface of the water in the graduated section of the trap, which were not penetrated by the water condensed immediately thereafter. This resulted in alternate columns of oil and water in the graduated section. These were returned to the distilling flask in the same order as

ASTM D889-23

<https://standards.iteh.ai/catalog/standards/sist/fba58471-aa33-4162-be5c-223962ef7293/astm-d889-23>

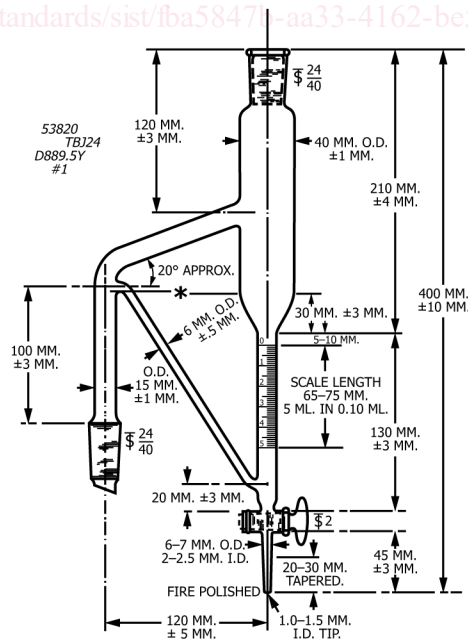

* BOTTOM OF SEAL OF SMALL RETURN TUBE TO BE AT OR SLIGHTLY ABOVE START OF TAPER OF THE LARGE TUBE

FIG. 2 Trap

they occurred, through the side arm of the trap. As this condition continued indefinitely, it was impossible to completely remove all the oil from the rosin. By raising the opening of the side arm of the trap to the position shown, to bring the surface of the liquid into the wide part of the trap above the narrow graduated section, the oil is collected in a thinner film that can be penetrated readily by the droplets of water falling from the end of the condenser, and only the water is thus collected in the narrow graduated section. At the end of the test, the oil is slowly brought down into the graduated section and its volume read. The system or apparatus loss amounts to not more than 0.1 mL of oil.

4.3 *Condenser*, straight-tube, ~~300-mm~~, 300 mm, water-jacketed reflux type, with a 24/40 standard-taper ground joint for connection with the trap.

4.4 *Heat Source*—An oil bath containing high-temperature-resistant oil, or an electric heater of the mantle type in which the heating elements are encased in a glass cloth mantle of such shape as to partially or completely surround the flask being heated.

4.5 *Thermometer*, having a range from ~~30 to 200°C~~, 30 °C to 200 °C, ASTM 16C or equivalent (see Specification E1). Alternatively any mercury free temperature measuring device with precision equivalent to those listed in Specification E1 may be used.

4.6 *Glass Beads*.

5. Procedure

5.1 Place 50 g of the crushed sample in the flask, add ~~125 mL~~ 125 mL of a glycerin-water solution (4 + 1), add a few glass beads, insert an ebullition tube, and connect the flask with the trap. Fill the trap (Fig. 2) with water through the top opening until the water level is even with the bottom of the seal of the small return tube to the side arm. Insert the thermometer, and connect the condenser.

5.2 Regulate the applied heat until the liquid in the flask is brought to a boil and distillation continues at a constant temperature, which will be about ~~125°C~~ 125 °C at the start. At this stage, open the stopcock slightly and withdraw the water from the trap into a small graduated cylinder at the rate of 1 drop to 5 drops off the lower end of the condenser. Control the reflux rate so that no uncondensed vapors escape from the top of the condenser. The withdrawal of water from the system should be at the rate of about 1 mL/min. Increase the heat from time to time to maintain uniform continuous operation with slowly rising temperature. Discontinue the distillation when the temperature reaches ~~180°C~~ 180 °C.

5.3 Remove the source of heat and allow the distillation to subside (Note 2). Draw off water until all the oil is brought into the graduated section of the trap and note the volume. The density of the oil is usually very close to 1.00.

NOTE 2—The contents of the flask should be poured out while still warm, before the rosin has become viscous or solid, to facilitate cleaning and avoid strain on the glass when the rosin becomes cold.

6. Report

6.1 Properly made rosin yields not more than 0.5 mL of residual volatile oil per 50 g of sample. If the recovered oil is within such limit, report the rosin as free of excess volatile oil. If more than 0.5 mL of oil is recovered, report the total volume obtained.

NOTE 3—The volatile oil recovered from gum rosin consists primarily of high-boiling terpene components of the crude gum, most of which under proper distillation will have been recovered as turpentine by the time the rosin is drawn from the still. Faulty distillation or premature withdrawal may yield a rosin giving a higher than normal recovery of oil, with a refractive index below 1.483. The polymerization residue should have a refractive index not lower than 1.500. In the case of wood rosins, generally obtained by extraction from stumpwood with a petroleum or naphtha solvent, any recovered oil would probably consist of unrecovered solvent. The refractive index of both the recovered oil and the polymerization residue therefrom would be well under the above figures for gum rosin.

7. Additional Examination of Oil

7.1 Drain off the water, transfer the oil to a small glass container, stopper, and allow to settle until clear. Note the odor and determine the refractive index. For further information on the nature of the oil, volume permitting, make a polymerization test according to the procedure given in Test Methods D233.