



Designation: **D6090—17** **D6090 – 23**

Standard Test Method for Softening Point Resins (Mettler Cup and Ball Method)¹

This standard is issued under the fixed designation D6090; the number immediately following the designation indicates the year of original adoption or, in the case of revision, the year of last revision. A number in parentheses indicates the year of last reapproval. A superscript epsilon (ϵ) indicates an editorial change since the last revision or reapproval.

1. Scope

1.1 This test method covers the determination of softening point of resins using a Mettler cup and ball apparatus, and may, under user-defined conditions, give results comparable to those obtained by Test Methods **E28**.

1.2 The values stated in SI units are to be regarded as the standard. The values given in parentheses are for information only.

1.3 *This standard does not purport to address all of the safety concerns, if any, associated with its use. It is the responsibility of the user of this standard to establish appropriate safety, health, and environmental practices and determine the applicability of regulatory limitations prior to use.*

1.4 *This international standard was developed in accordance with internationally recognized principles on standardization established in the Decision on Principles for the Development of International Standards, Guides and Recommendations issued by the World Trade Organization Technical Barriers to Trade (TBT) Committee.*

2. Referenced Documents

2.1 ASTM Standards:²

E28 Test Methods for Softening Point of Resins Derived from Pine Chemicals and Hydrocarbons, by Ring-and-Ball Apparatus

E177 Practice for Use of the Terms Precision and Bias in ASTM Test Methods

E691 Practice for Conducting an Interlaboratory Study to Determine the Precision of a Test Method <https://www.astm.org/standards/E691>

3. Summary of Test Method

3.1 In this test method, the softening point is defined as the temperature at which the sample, suspended in a cylindrical cup with a ~~6.35-mm~~ **6.35 mm** hole in the bottom and with a stainless steel ball, ~~88.7~~ **88.7** mm in diameter, centered on top of the sample in the cup, flows downward a distance of 19 mm to interrupt a light beam, as the sample is heated at a linear rate in air.

4. Significance and Use

4.1 In general, with materials of these types, softening point does not take place at a definite temperature. As the temperature rises, these materials gradually change from brittle or exceedingly thick and slow-flowing materials to softer and less viscous liquids. For this reason, the determination of the softening point must be made by a fixed, arbitrary, and closely defined method if the results obtained are to be comparable.

¹ This test method is under the jurisdiction of ASTM Committee **D01** on Paint and Related Coatings, Materials, and Applications and is the direct responsibility of Subcommittee **D01.34** on Pine Chemicals and Hydrocarbon Resins.

Current edition approved Dec. 1, 2017; Feb. 1, 2023. Published December 2017; March 2023. Originally approved in 1997. Last previous edition approved in 2012 as **D6090—12**; **D6090 – 17**. DOI: [10.1520/D6090-17](https://doi.org/10.1520/D6090-17); [10.1520/D6090-23](https://doi.org/10.1520/D6090-23).

² For referenced ASTM standards, visit the ASTM website, www.astm.org, or contact ASTM Customer Service at service@astm.org. For *Annual Book of ASTM Standards* volume information, refer to the standard's Document Summary page on the ASTM website.

5. Apparatus

5.1 *Softening Point Apparatus*³—This commercially available instrument consists of a control unit with a digital temperature indicator; matched measuring cell; cartridge assembly, consisting of a sample cup and upper portion; and accessories. The control unit automatically regulates the heating rate of the measuring cell. The softening point is indicated on the readout, and the heating program stopped, when the sample flow triggers a photocell detector.

5.2 *Central Processor*—This unit shall provide a continuous, linear temperature increase from 25 to 375°C; 25 °C to 375 °C.

5.3 *Measuring Cell*—This unit shall be capable of heating a sample cup assembly, as described in 5.4, at a linear rate with an accuracy of $\pm 0.2^\circ\text{C}/\text{min}$; $\pm 0.2^\circ\text{C}/\text{min}$. It shall include a sensing system capable of detecting the softening point with a precision of 0.1°C ; 0.1°C .

5.4 *Sample Cup Assembly*—A cup of chromium-plated brass and an upper portion, conforming to the dimensions shown in Fig. 1.

5.5 *Ball*—A stainless steel ball, 8.7 mm ($1\frac{1}{32}$ in.) in diameter, weighing $2.772.77\text{ g} \pm 0.02\text{ g}$.

6. Calibration of Apparatus Using a Primary Standard

6.1 This step, required only occasionally, is designed to establish that the temperature indicated by the instrument is in agreement with a known standard. A special cup with a bottom orifice of 2.8 mm is used instead of the one specified for testing the resin.

NOTE 1—The stainless steel ball is not used during calibration.

6.2 *Reagent*—Use either analytical reagent or primary standard grade benzoic acid for the calibration. As this material is hygroscopic, it must be stored in a tightly sealed container, and replaced with fresh material from a newly opened supply if hydration or other contamination is suspected.

6.3 *Procedure:*

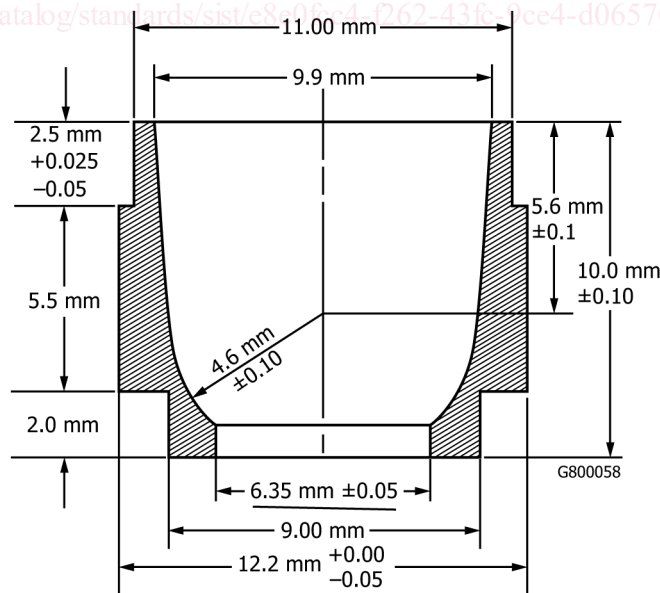

FIG. 1 Sample Cup

³ The sole source of supply of the apparatus FP90/FP83HT, known to the committee at this time is the Mettler-Toledo, Inc., Princeton-Hightstown Rd., Hightstown, NJ 08520. If you are aware of alternative suppliers, please provide this information to ASTM International Headquarters. Your comments will receive careful consideration at a meeting of the responsible technical committee,¹ which you may attend.

6.3.1 *Filling the Sample Cup*—Place the cup on a clean, flat surface and fill it with benzoic acid crystals. Hand press the material into the cup with a ~~9.2-mm~~ 9.2 mm rod of dowel stock or equivalent. Refill and repeat the pressing step until the cup is filled with benzoic acid. Remove any crystals from the exterior of the cup.

6.3.2 *Heating*—Preheat the measuring cell to ~~121°C~~, 121 °C, and maintain it at that temperature. Place the cartridge assembly containing the benzoic acid in position in the measuring cell, taking care that the slits for the light beam are properly positioned. With the instrument set in the dropping point mode, start the required method, which includes a waiting period of 30 s to allow temperature equilibration between the measuring cell and sample followed by an automatic temperature ramp of ~~0.2°C/min~~ 0.2 °C/min. The temperature will rise steadily at the correct rate until the drop point is reached, and then remain steady on the readout.

6.3.3 *Cleaning*—Immediately remove the cartridge assembly. Check to determine that the sample has passed through the light beam and no pre-triggering has occurred. If a malfunction is suspected, the entire procedure must be repeated. Inspect the apparatus carefully to ensure that no residue remains. Wash the cartridge parts with a suitable solvent to remove the last traces of the residue.

6.3.4 *Interpretation*—If the result is not ~~123.5 ± 0.5°C~~, 123.5 °C ± 0.5 °C, repeat the test. If the second value remains outside of the acceptable range, repeat the test using a fresh sample of benzoic acid. If the results remain outside of the acceptable range, the instrument requires recalibration or repair. Consult the manufacturer’s instruction manual.

7. Instrument Check of Apparatus Using a Secondary Standard

7.1 The primary calibration standard, benzoic acid, might not have a dropping point similar to the softening point of the resin being tested. In such cases, it is desirable to calibrate the instrument using a secondary standard having a dropping point similar to that of the test sample. Materials suitable for use as secondary standards are listed, but are not limited to those, in [Table 1](#). Demonstration of conformance to the dropping point of benzoic acid should be completed before a secondary standard is read.

7.2 Follow the same procedure as in [6.3.2](#) and [6.3.3](#) but start about ~~3°C~~ 3 °C below the actual dropping point of the secondary standard.

8. Preparation of Sample

8.1 Fold the tab on an oil-free disposable aluminum weighing dish to a horizontal position and pinch a pour spout into the dish directly opposite the tab. Weigh ~~5 to 10 g~~ 5 g to 10 g of resin into the dish.

8.2 Place the dish and sample on a preheated hot plate and cover with a ~~600-mL~~ 600 mL or larger beaker. Heat the sample until it is almost melted.

8.3 Remove the beaker from the hot plate, grasp the tab with forceps or needle-nose pliers, and stir the sample with a probe-type thermometer until it is completely melted and homogeneous. Avoid entraining air into the sample melt. The temperature of the

TABLE 1 Materials Suitable as Secondary Standards for Mettler Cup and Ball Softening Point

Approximate Dropping Point, °C	Material
60	stearyl alcohol
80	diphenyl carbonate naphthalene
100	phenoxyacetic acid 4- <i>t</i> -butylphenol methyl urea
110	<i>m</i> -toluic acid resorcinol
120	benzoic acid
130	methyl 4-hydroxybenzoate urea benzamide
140	1,10-decanedicarboxylic acid dimethyl terephthalate <i>o</i> -toluamide