



Designation: D1657 – 22^ε¹



Manual of Petroleum Measurement Standards (MPMS), Chapter 9.2

Standard Test Method for Density or Relative Density of Light Hydrocarbons by Pressure Hydrometer¹

This standard is issued under the fixed designation D1657; the number immediately following the designation indicates the year of original adoption or, in the case of revision, the year of last revision. A number in parentheses indicates the year of last reapproval. A superscript epsilon (ϵ) indicates an editorial change since the last revision or reapproval.

^ε¹ NOTE—Editorially corrected adjunct information in March 2023.

1. Scope*

1.1 This test method covers the determination of the density or relative density of light hydrocarbons including liquefied petroleum gases (LPG) having Reid vapor pressures exceeding 101.325 kPa (14.696 psi).

1.2 The prescribed apparatus should not be used for materials having vapor pressures higher than 1.4 MPa (200 psi) at the test temperature. This pressure limit is dictated by the type of equipment. Higher pressures can apply to other equipment designs.

1.3 The initial pressure hydrometer readings obtained are uncorrected hydrometer readings and not density measurements. Readings are measured on a hydrometer at either the reference temperature or at another convenient temperature, and readings are corrected for the meniscus effect, the thermal glass expansion effect, alternate calibration temperature effects and to the reference temperature by means of calculations and Adjunct to **D1250** Guide for Petroleum Measurement Tables (API *MPMS* Chapter 11.1) or API *MPMS* Chapter 11.2.4 (GPA TP-27), as applicable.

1.4 Values determined as density or relative density can be converted to equivalent values in the other units or alternative reference temperatures by means of Interconversion Procedures API *MPMS* Chapter 11.5, or Adjunct to **D1250** Guide for Petroleum Measurement Tables (API *MPMS* Chapter 11.1) or API *MPMS* Chapter 11.2.4 (GPA TP-27), as applicable.

1.5 The calculations required in Section 11 shall be applied to the initial pressure hydrometer reading with observations

¹ This test method is under the jurisdiction of ASTM Committee D02 on Petroleum Products, Liquid Fuels, and Lubricants and the API Committee on Petroleum Measurement, and is the direct responsibility of Subcommittee D02.02/COMQ, the joint ASTM-API Committee on Hydrocarbon Measurement for Custody Transfer (Joint ASTM-API). This test method has been approved by the sponsoring committees and accepted by the Cooperating Societies in accordance with established procedures.

Current edition approved July 1, 2022. Published July 2022. Originally approved in 1939. Last previous edition approved in 2017 as D1657 – 12 (2017). DOI: 10.1520/D1657-22E01.

and results reported as required by Section 11 prior to use in a subsequent calculation procedure (measurement ticket calculation, meter factor calculation, or base prover volume determination).

1.6 **Annex A1** contains a procedure for verifying or certifying the equipment for this test method.

1.7 The values in SI units are to be regarded as the standard. US Customary values shown in adjacent parentheses are for information only and may not be exactly equivalent. Both SI and customary units have been rounded so that they may not be exactly equivalent.

1.8 *This standard does not purport to address all of the safety concerns, if any, associated with its use. It is the responsibility of the user of this standard to establish appropriate safety, health, and environmental practices and determine the applicability of regulatory limitations prior to use.*

1.9 *This international standard was developed in accordance with internationally recognized principles on standardization established in the Decision on Principles for the Development of International Standards, Guides and Recommendations issued by the World Trade Organization Technical Barriers to Trade (TBT) Committee.*

2. Referenced Documents

2.1 ASTM Standards:²

D1250 Guide for the Use of the Joint API and ASTM Adjunct for Temperature and Pressure Volume Correction Factors for Generalized Crude Oils, Refined Products, and Lubricating Oils: API *MPMS* Chapter 11.1

D1265 Practice for Sampling Liquefied Petroleum (LP) Gases, Manual Method

D1298 Test Method for Density, Relative Density, and API Gravity of Crude Petroleum and Liquid Petroleum Products by Hydrometer Method (API *MPMS* Chapter 9.1)

² For referenced ASTM standards, visit the ASTM website, www.astm.org, or contact ASTM Customer Service at service@astm.org. For *Annual Book of ASTM Standards* volume information, refer to the standard's Document Summary page on the ASTM website.

*A Summary of Changes section appears at the end of this standard

D4175 Terminology Relating to Petroleum Products, Liquid Fuels, and Lubricants

E1 Specification for ASTM Liquid-in-Glass Thermometers

E100 Specification for ASTM Hydrometers

2.2 *API Standards*:³

MPMS Chapter 1 Terms and Definitions Database

MPMS Chapter 9.1 Test Method for Density, Relative Density, and API Gravity of Crude Petroleum and Liquid Petroleum Products by Hydrometer Method (ASTM Test Method **D1298**)

MPMS Chapter 11.1 Temperature and Pressure Volume Correction Factors for Generalized Crude Oils, Refined Products and Lubricating Oils (Adjunct to ASTM **D1250**)

MPMS Chapter 11.2.2 Compressibility Factors for Hydrocarbons: 0.350-0.0637 Relative Density (60°F/60°F) and -50°F to 140°F Metering Temperature

MPMS Chapter 11.2.2M Compressibility Factors for Hydrocarbons: 350-637 Kilograms per Cubic Meter Density 15°C and -46°C to 60°C Metering Temperatures

MPMS Chapter 11.2.4 Temperature Correction for the Volume of NGL and LPG Tables 23E, 24E, 53E, 54E, 59E and 60E (joint standard with GPA TP-27)

MPMS Chapter 11.5 Density/Weight/Volume Intraconversion

2.3 *GPA Standards*:⁴

GPA Technical Publication TP-27 Temperature Correction for the Volume of NGL and LPG, Tables 23E, 24E, 53E, 54E, 59E and 60E (joint standard with *API MPMS* Chapter 11.2.4)

2.4 *ASTM Adjuncts*:

Adjunct to **D1250** Standard Guide for the Use of the Joint *API* and *ASTM* Adjunct for Temperature and Pressure Volume Correction Factors for Generalized Crude Oils, Refined Products, and Lubricant Oils: *API MPMS* Chapter 11.1, Addenda 1 and 2⁵

3. Terminology

3.1 *Definitions*:

3.1.1 For definitions of terms used in this standard test method, refer to Terminology **D4175** and the *API MPMS* Chapter 1 Terms and Definitions Database.

3.1.2 *density, n*—the mass of liquid per unit volume at 15 °C and its saturation pressure with the standard unit of measurement being kilograms per cubic metre.

3.1.2.1 *Discussion*—Other reference temperatures, such as 20 °C may be used for some products or in some locations. Less preferred units of measurement; for example, kg/L or g/mL, are still in use.

3.1.3 *relative density (specific gravity), n*—the ratio of the mass of a given volume of liquid at a specific temperature to

the mass of an equal volume of pure water at the same or different temperature. Both reference temperatures shall be explicitly stated.

3.1.3.1 *Discussion*—Common reference temperatures include 60/60 °F, 20/20 °C, 20/4 °C. The historic deprecated term “specific gravity” may still be found.

3.1.4 *thermohydrometer, n*—a glass hydrometer with a self-contained mercury thermometer.

4. Summary of Test Method

4.1 The apparatus is purged with a portion of the sample before filling with the portion to be used for testing. The pressure cylinder is filled to a level at which the enclosed hydrometer floats freely, and the cylinder is then placed in a constant-temperature bath (if needed). When the temperature has reached equilibrium, the hydrometer reading and the temperature of the sample are read. The observed hydrometer reading is corrected for the meniscus effect, alternate calibration temperature effects and reduced to the reference temperature by means of the volume correction factors or tables as applicable by use of the appropriate Adjunct to **D1250** Guide for Petroleum Measurement Tables (*API MPMS* Chapter 11.1) or *API MPMS* Chapter 11.2.4 (GPA TP-27), as applicable, and observed temperature from the thermometer.

5. Significance and Use

5.1 The density or relative density of light hydrocarbons and liquefied petroleum gases is used in custody transfer quantity calculations or to satisfy transportation, storage, and regulatory requirements.

6. Apparatus

6.1 *Hydrometers*, graduated in density with a range from 500 kg/m³ to 650 kg/m³, or in relative density with a range from 0.500 to 0.650, and conforming to the dimensions in Specification **E100**.

6.1.1 *Thermohydrometers*, for field applications, thermohydrometers may be more convenient than hydrometers with separate thermometers. They shall conform to Specification **E100**, Thermohydrometer Nos. 101H or 310H.

6.1.1.1 Thermohydrometers shall be of suitable range and have dimensions to float freely within the pressure hydrometer cylinder with clearances of 5 mm at the wall and 25 mm at the top and bottom.

6.1.1.2 The test report shall state that a thermohydrometer was used.

6.1.1.3 The user should ascertain that the instruments used for this procedure conform to the requirements set out above with respect to materials, dimensions, and scale errors. In cases where the instrument is provided with a calibration certificate issued by a recognized standardizing body, the instrument is classed as certified and the appropriate corrections for the meniscus effect, the thermal glass expansion effect, and alternate calibration temperature effects shall be applied to the observed readings prior to corrections. Instruments that satisfy the requirements of this test method, but are not provided with a recognized calibration certificate, are classed as uncertified and the appropriate corrections for the meniscus effect, the

³ Available from American Petroleum Institute (API), 1220 L. St., NW, Washington, DC 20005-4070, <http://www.api.org>.

⁴ Available from Gas Processors Association (GPA), 6526 E. 60th St., Tulsa, OK 74145, <http://www.gpaglobal.org>.

⁵ Available from ASTM International Headquarters. Order Adjunct No. **ADJD1250-A1A2-E-PDF**. Original adjunct produced in 1983.

thermal glass expansion effect, and alternative calibration temperature effects shall be applied to the observed readings prior to corrections.

6.2 *Hydrometer Cylinder*, constructed of transparent plastic; for example, poly(methyl methacrylate) or equivalent material,

conforming to the design and recommended dimensions given in Fig. 1. The cylinder shall be of such dimensions that the hydrometer shall float freely within it. The ends shall be tightly sealed with neoprene gaskets and metal end plates as shown in Fig. 1. (**Warning**—A protective shield shall be placed around

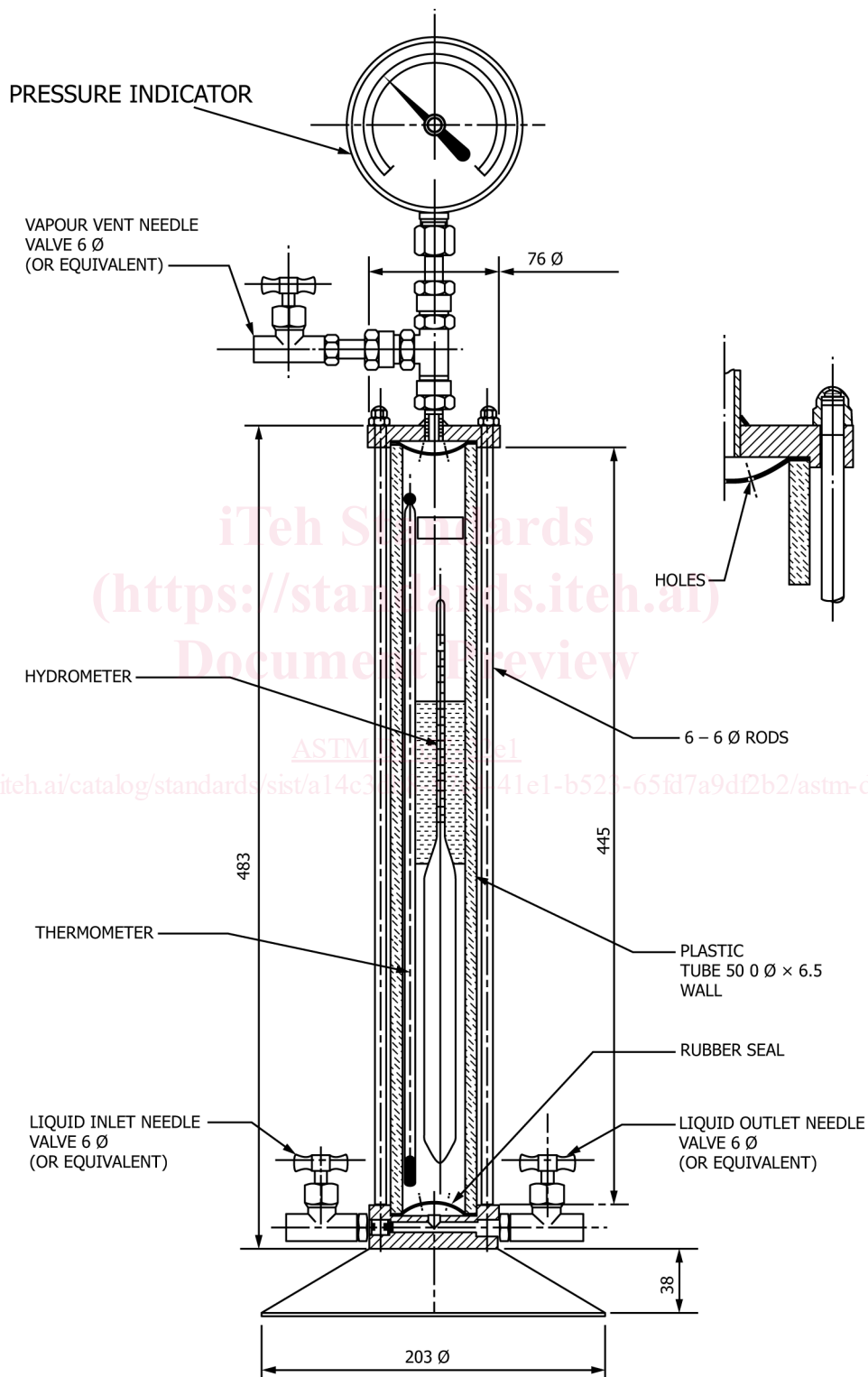

FIG. 1 Pressure Hydrometer Cylinder

the cylinder. Replace any cylinders that show signs of fogging, crazing, cracking, or etching.)

NOTE 1—Certain compounds attack plastics and cloud the inner surface of the cylinder, making it difficult or impossible to read the hydrometer. Tests showed no attack by ethane, ethene (ethylene), propane, propylene, butane, methylpropane (isobutane), butenes (normal butylenes), methylpropene (isobutylene), pentane, and methylbutane (isopentane), and no attack is expected from butadiene and acetaldehyde. Users are cautioned, however, to clean the cylinder thoroughly after each determination. Ketones and alcohols should not be used for cleaning as they attack and weaken plastics while aromatics also tend to attack the surface of plastics and should similarly not be used. A light aliphatic hydrocarbon is recommended for cleaning. (**Warning**—Extremely flammable. Harmful if inhaled. Vapors may cause flash fire.)

6.2.1 The liquid inlet valve and the liquid outlet valve shall be tightly connected to a base plate that shall be bored to give both valves a common inlet to the cylinder. The vapor vent valve shall be similarly connected to the top plate, which shall be bored to provide a vapor outlet from the pressure cylinder. All valves shall be 6 mm (¼ in.) or equivalent needle valves.

6.2.2 The cylinder shall not be operated at a gage pressure greater than 1.4 MPa (200 psi). A hydrostatic test at 2.8 MPa (400 psi) shall be carried out at intervals no greater than 12 months.

NOTE 2—For Safety—The cylinder should be equipped with appropriate safety devices to prevent over-pressure. Consideration should be given to pressure testing the cylinder at 1.25 to 1.5 times its normal maximum operating pressure on a periodic basis, not to exceed two years.

6.3 *Thermometers*, conforming to ASTM 12C or 12F in Specification E1. The thermometer shall be held firmly inside the hydrometer cylinder by a clip in such a manner that it does not interfere with the free movement of the hydrometer.

6.4 *Constant-Temperature Bath*, of dimensions such that it can accommodate the hydrometer cylinder with the test portion fully immersed below the test portion liquid surface, and a temperature control system capable of maintaining the bath temperature within 0.25 °C of the test temperature throughout the duration of the test.

7. Reference Liquids

7.1 The following reference liquids are required for standardization of the hydrometer:

7.1.1 *Propane*, pure grade, having a nominal density of 507.6 kg/m³ at 15 °C or a relative density 60/60 °F of 0.50699. (**Warning**—Extremely flammable. Harmful if inhaled. Vapors may cause flash fire.) The density of the reference liquid used shall be known.

7.1.2 *Butane*, pure grade, having a nominal density of 584.1 kg/m³ at 15 °C or a relative density 60/60 °F of 0.5840. (**Warning**—Extremely flammable. Harmful if inhaled. Vapors may cause flash fire.) The density of the reference liquid used shall be known.

8. Sampling

8.1 Unless otherwise specified, samples of liquid hydrocarbons shall be obtained by the procedures described in Practice D1265. The procedure for sampling for verification of the apparatus and for subsequent testing is described as follows.

8.1.1 Connect the source of supply of the liquid to be tested to the inlet valve by suitable fittings so that a representative sample can be introduced into the cylinder. Ascertain that these connections are free of leaks. Open the outlet and vent valves and purge the sampling connections by opening the inlet valve slightly, permitting the product to flow through the outlet valve at the bottom of the cylinder and the vent valve at the top of the cylinder.

8.1.2 When the connections have been purged, close the outlet and vent valves and open the inlet valve, permitting the liquid to enter the cylinder until it is full. If necessary, the vent valve may be opened slightly to permit complete filling of the cylinder after which it shall be closed. At no time shall the pressure in the cylinder be allowed to rise above a gage pressure of 1.4 MPa (200 psi).

8.1.3 When the cylinder has been filled, close the inlet valve and open the outlet and vent valves, permitting the contents of the cylinder to be withdrawn completely and the pressure inside the cylinder to be returned to atmospheric pressure.

8.1.4 Close the outlet and vent valves and open the inlet valve, filling the cylinder to a level at which the enclosed hydrometer floats freely. If it is necessary to accomplish this filling by venting vapor through the vent valve, repeat the purging to cool the cylinder sufficiently to permit its being filled without venting.

8.1.5 With all valves closed, examine the apparatus for leaks. If leaks are detected, discard the sample, reduce the pressure to atmospheric and repair the leaks. Repeat the sampling procedure.

9. Verification of Apparatus

9.1 Carefully clean and dry the hydrometer and the inside wall of the pressure cylinder.

9.2 Insert the hydrometer in the pressure cylinder and attach the thermometer and cover plate. Connect the source of supply of the reference liquid to the inlet valve and ascertain that the connections are free of leaks. Fill the hydrometer with one of the reference fluids (see Section 7) by the procedure given in 8.1.2 – 8.1.5.

9.3 Disconnect the hydrometer cylinder from the source of supply of liquid and place it in the constant-temperature bath maintained within 0.2 °C of the test temperature until thermal equilibrium has been obtained. To accelerate thermal adjustment, occasionally remove the hydrometer cylinder from the constant-temperature bath, tilt to a horizontal position, rock gently a few times to ensure mixing, and replace in the constant-temperature bath. Exercise care to prevent damage to the hydrometer and thermometer.

9.4 When the hydrometer cylinder and thermometer have reached equilibrium, as shown by the thermometer inside the cylinder, remove the cylinder from the constant-temperature bath, stand it on a firm level surface, and while the hydrometer is floating freely, take the hydrometer reading promptly as described in 9.4.1 and 9.4.2.

9.4.1 Observe a point slightly below the plane of the liquid surface and then raise the line of vision until this surface, seen as an ellipse, becomes a straight line. Record the point where