



Designation: D5953M – 23

# Standard Test Method for Determination of Non-methane Organic Compounds (NMOC) in Ambient Air Using Cryogenic Preconcentration and Direct Flame Ionization Detection<sup>1</sup>

This standard is issued under the fixed designation D5953M; the number immediately following the designation indicates the year of original adoption or, in the case of revision, the year of last revision. A number in parentheses indicates the year of last reapproval. A superscript epsilon ( $\epsilon$ ) indicates an editorial change since the last revision or reapproval.

## 1. Scope

1.1 This test method<sup>2</sup> presents a procedure for sampling and determination of non-methane organic compounds (NMOC) in ambient, indoor, or workplace atmospheres.

1.2 This test method describes the collection of integrated whole air samples in silanized or other passivated stainless steel canisters, and their subsequent laboratory analysis.

1.2.1 This test method describes a procedure for sampling in canisters at final pressures above atmospheric pressure (pressurized sampling).

1.3 This test method employs a cryogenic trapping procedure for concentration of the NMOC prior to analysis.

1.4 This test method describes the determination of the NMOC by the flame ionization detection (FID), without the use of gas chromatographic columns and other procedures necessary for species separation.

1.5 The range of this test method is from 20 ppb C to 10 000 ppb C (1, 2).<sup>3</sup>

1.6 This test method has a larger uncertainty for some halogenated or oxygenated hydrocarbons than for simple hydrocarbons or aromatic compounds. This is especially true if there are high concentrations of chlorocarbons or chlorofluorocarbons present.

1.7 The values stated in SI units are to be regarded as standard. The values given in parentheses are mathematical

conversions to inch-pound units that are provided for information only and are not considered standard.

1.8 *This standard does not purport to address all of the safety concerns, if any, associated with its use. It is the responsibility of the user of this standard to establish appropriate safety, health, and environmental practices and determine the applicability of regulatory limitations prior to use.*

1.9 *This international standard was developed in accordance with internationally recognized principles on standardization established in the Decision on Principles for the Development of International Standards, Guides and Recommendations issued by the World Trade Organization Technical Barriers to Trade (TBT) Committee.*

## 2. Referenced Documents

### 2.1 ASTM Standards:<sup>4</sup>

D1193 Specification for Reagent Water

D1356 Terminology Relating to Sampling and Analysis of Atmospheres

D1357 Practice for Planning the Sampling of the Ambient Atmosphere

D5466 Test Method for Determination of Volatile Organic Compounds in Atmospheres (Canister Sampling, Mass Spectrometry Analysis Methodology)

### 2.2 Other References:

EPA Method TO-12 Determination of Non-Methane Organic Compounds (NMOC) in Ambient Air Using Cryogenic Pre-Concentration and Direct Flame Ionization Detection (PDFID)<sup>5</sup>

## 3. Terminology

3.1 *Definitions*—For definitions of terms used in this test method, refer to Terminology D1356.

<sup>1</sup> This test method is under the jurisdiction of ASTM Committee D22 on Air Quality and is the direct responsibility of Subcommittee D22.03 on Ambient Atmospheres and Source Emissions.

Current edition approved March 1, 2023. Published March 2023. Originally approved in 1996. Last previous edition approved in 2016 as D5953M – 16. DOI: 10.1520/D5953M-23.

<sup>2</sup> This test method is based on EPA Compendium Method TO-12: "Determination of Non-Methane Organic Compounds (NMOC) in Ambient Air Using Cryogenic Pre-Concentration and Direct Flame Ionization Detection (PDFID)," *Compendium of Methods for the Determination of Toxic Organic Compounds in Ambient Air*, EPA 600/4-89-017, U.S. Environmental Protection Agency, Research Triangle Park, NC, March 1990.

<sup>3</sup> The boldface numbers in parentheses refer to the list of references at the end of this standard.

<sup>4</sup> For referenced ASTM standards, visit the ASTM website, [www.astm.org](http://www.astm.org), or contact ASTM Customer Service at [service@astm.org](mailto:service@astm.org). For *Annual Book of ASTM Standards* volume information, refer to the standard's Document Summary page on the ASTM website.

<sup>5</sup> Available from United States Environmental Protection Agency (EPA), William Jefferson Clinton Bldg., 1200 Pennsylvania Ave., NW, Washington, DC 20460, <http://www.epa.gov>.

### 3.2 Definitions of Terms Specific to This Standard:

3.2.1 *cryogen*—a refrigerant used to obtain very low temperatures in analytical system cryogenic traps.

3.2.1.1 *Discussion*—Liquid argon (bp  $-185.7\text{ }^{\circ}\text{C}$  at standard pressure) is recommended and may be required for use in some applications of this test method. Cryogenics with lower boiling points, such as liquid nitrogen, may be used if the cryogenic trap temperature is actively maintained at  $-185\text{ }^{\circ}\text{C}$  to avoid the potential for trapping oxygen or methane from air samples.

3.2.2 *dynamic calibration*—calibration of an analytical system with pollutant concentrations that are generated in a dynamic, flowing system, such as by quantitative, flow-rate dilution of a high-concentration gas standard with zero gas.

3.2.3 *NMOC*—non-methane organic compounds.

3.2.3.1 *Discussion*—Total non-methane organic compounds are compounds, excluding methane, measured using a flame ionization detector (FID), with vapor pressures above  $10^{-2}$  kPa recovered from canisters.

3.2.4 *ppm C and ppb C*—concentration units of parts-per-million and parts-per-billion of organic carbon as detected by FID.

3.2.4.1 *Discussion*—For example, when calibrating with propane, concentrations of NMOC in samples are equivalent to parts-per-million by volume (ppm (v)) or parts-per-billion by volume (ppb (v)) multiplied by the number of carbon atoms in propane, which is three (3).

## 4. Summary of Test Method (2-6)

4.1 An air sample is collected directly from ambient air, using a pre-cleaned sample evacuated passivated canister, which is then transported to a laboratory.

4.2 A fixed-volume portion of the sample air is drawn from the canister at a low flow rate through a silanized glass-bead filled trap that is cooled to approximately  $-186\text{ }^{\circ}\text{C}$  with liquid argon. The cryogenic trap simultaneously collects and concentrates the NMOC using condensation, while allowing the nitrogen, oxygen, methane, and other compounds with boiling points below  $-186\text{ }^{\circ}\text{C}$  to pass through the trap without retention. The system is dynamically calibrated so that the volume of sample passing through the trap does not have to be quantitatively measured, but must be precisely repeatable between the calibration and the analytical phases.

4.3 After the fixed-volume air sample has been drawn through the trap, a helium carrier gas flow is diverted to pass through the trap, in the opposite direction to the sample flow, and into an FID. When the residual air and methane have been flushed from the trap and the FID baseline restabilizes, the cryogen is removed and the temperature of the trap is raised to  $90\text{ }^{\circ}\text{C}$  at  $30\text{ }^{\circ}\text{C}$  per minute.

4.4 The organic compounds previously collected on the trap re-volatilize and are carried into the FID, resulting in a response peak or peaks from the FID. The area of the peak or peaks is integrated, and the integrated value is translated to concentration units using a previously obtained calibration curve relating integrated peak areas with known concentrations of propane or other calibrant.

4.5 The cryogenic trap simultaneously concentrates the NMOC while separating and removing the methane from samples. The technique thus directly measures NMOC with greater sensitivity than conventional continuous NMOC analyzers due to the pre-concentration procedure.

4.6 The sample is injected into the hydrogen-rich flame of an FID, where the organic vapors burn, producing ionized molecular fragments. The resulting ion fragments are then collected and detected. Because this test method employs a helium carrier gas, the detector response is nearly identical for many hydrocarbon compounds commonly of interest. Thus, the historical short-coming of varying FID response to aromatic, olefinic, and paraffinic hydrocarbons is minimized. Users are cautioned that the FID is much less sensitive to most organic compounds containing functional groups such as carbonyls, alcohols, halocarbons, etc. than simple hydrocarbons.

## 5. Significance and Use

5.1 Many regulators, industrial processes, and other stakeholders require determination of NMOC in atmospheres.

5.2 Accurate measurements of ambient NMOC concentrations are critical in devising air pollution control strategies and in assessing control effectiveness because NMOCs are primary precursors of atmospheric ozone and other oxidants (7, 8).

5.2.1 The NMOC concentrations typically found at urban sites may range up to 1 ppm C to 3 ppm C or higher. In order to determine transport of precursors into an area monitoring site, measurement of NMOC upwind of the site may be necessary. Rural NMOC concentrations originating from areas free from NMOC sources are likely to be less than a few tenths of 1 ppm C.

5.3 Conventional test methods based upon gas chromatography and qualitative and quantitative species evaluation are relatively time consuming, sometimes difficult and expensive in staff time and resources, and are not needed when only a measurement of NMOC is desired. The test method described requires only a simple, cryogenic pre-concentration procedure followed by direct detection with an FID. This test method provides a sensitive and accurate measurement of ambient total NMOC concentrations where speciated data are not required. Typical uses of this standard test method are as follows.

5.4 An application of the test method is the monitoring of the cleanliness of canisters.

5.5 Another use of the test method is the screening of canister samples prior to analysis.

5.6 Collection of ambient air samples in pressurized canisters provides the following advantages:

5.6.1 Convenient collection of integrated ambient samples over a specific time period,

5.6.2 Capability of remote sampling with subsequent central laboratory analysis,

5.6.3 Ability to ship and store samples, if necessary,

5.6.4 Unattended sample collection,

5.6.5 Analysis of samples from multiple sites with one analytical system,

5.6.6 Collection of replicate samples for assessment of measurement precision, and

5.6.7 Specific hydrocarbon analysis can be performed with the same sample system.

## 6. Interferences

6.1 In laboratory evaluations, moisture in the sample has been found to cause a positive shift in the FID baseline. The effect of this shift is minimized by carefully selecting the integration beginning and termination points and adjusting the baseline used for calculating the area of the NMOC peaks.

6.2 With helium as a carrier gas, FID response is uniform for most hydrocarbon compounds, but the response can vary considerably for other types of organic compounds such as halogenated and oxygenated compounds.

## 7. Apparatus

7.1 *Sample Collection System*, (Fig. 1).

7.1.1 *Sample Canister(s)*, stainless steel, stainless steel electropolished passivated Summa<sup>6</sup>-polished or silanized vessel(s) of 4 L to 6 L capacity, used for automatic collection of integrated air samples.

7.1.1.1 Mark each canister with a unique identification number.

7.1.2 *Sample Pump*, stainless steel, metal bellows type.

7.1.2.1 Ensure that the pump is free of leaks, and uncontaminated by oil or organic compounds.

7.1.2.2 Shock mount the pump to minimize vibration.

7.1.3 *Pressure Gauge*, 0 kPa to 210 kPa (0 psig to 30 psig).

7.1.4 *Solenoid Valve*, controls the sample flow to the canister with negligible temperature rise.

7.1.5 *Flow Control Device*, mass flow controller, micro-metering valve, or critical orifice, to maintain the sample flow over the sampling period.

7.1.6 *Particulate Matter Filter*, inert in-line filter, 2 μm or less, or other suitable filter, used to filter the air sample.

7.1.7 *Auxiliary Vacuum Pump or Blower*, draws sample air through the sample inlet line to reduce inlet residence time to no greater than 10 s.

7.1.7.1 Shock mount the pump to minimize vibration.

7.1.8 *Timer*, programmable, and electrically connected to the solenoid valve (7.1.4) and pumps (7.1.2 and 7.1.7), capable of controlling the pumps and the solenoid valve.

7.1.9 *Sample Inlet Line*, transports the sample air into the sample system, consisting of stainless steel tubing components.

7.2 *Sample Canister Cleaning System* (Fig. 2).

7.2.1 *Vacuum Pump*, capable of evacuating sample canister(s) to an absolute pressure of ≤1.69 kPa (29.5 in. Hg).

7.2.2 *Manifold*, stainless steel manifold with connections for simultaneously cleaning several canisters.

7.2.3 *Shut-off Valve(s)*, nine required.

7.2.4 *Pressure Gauge*, 0 kPa to 350 kPa (0 psig to 50 psig)—monitors zero-air pressure.

7.2.5 *Cryogenic Trap* (2 required), U-shaped open tubular trap cooled with liquid argon, used to prevent contamination from back diffusion of oil from vacuum pump, and providing clean, zero-air to the sample canister(s).

7.2.6 *Vacuum Gauge*, capable of measuring vacuum in the manifold to an absolute pressure of 1.69 kPa (29.5 in. Hg vacuum) or less, with scale divisions of 0.07 kPa (0.5 μm Hg).

7.2.7 *Flow Control Valve*, regulates flow of zero-air into the canister(s).

7.2.8 *Humidifier*, water bubbler or other system capable of providing moisture to the zero-air supply.

7.2.9 *Isothermal Oven*, for heating canisters, not shown in Fig. 2.

7.3 *Analytical System* (Fig. 3).

7.3.1 *FID System*, includes flow controls for the FID fuel and combustion air, temperature control for the FID, and signal processing electronics. Set the FID combustion air, hydrogen, and helium carrier flow rates according to the manufacturer's instructions.

7.3.2 *Data Reduction Device*, such as a computer, equipped with data acquisition hardware and software and a laser printer, or an electronic integrator, with chart recorder, capable of integrating the area of one or more FID response peaks and calculating peak area corrected for baseline drift.

7.3.2.1 If a discrete integrator and chart recorder are used, exercise care to ensure that these components do not interfere with each other electrically or electronically.

7.3.2.2 Range selector controls on both the integrator and the FID analyzer may not provide accurate range ratios, so prepare individual calibration curves for each range.

7.3.2.3 The integrator must be capable of marking the beginning and ending of peaks, constructing the appropriate baseline between the start and end of the integration period, and calculating the peak area.

7.3.3 *Cryogenic Trap*, constructed from a single piece of chromatographic-grade stainless steel tubing (3 mm outside diameter, 2 mm inside diameter), as shown in Fig. 4.

<sup>6</sup> The Summa process is a trademark of Molectrics, Inc., 4000 E. 89th St., Cleveland, OH 44105.

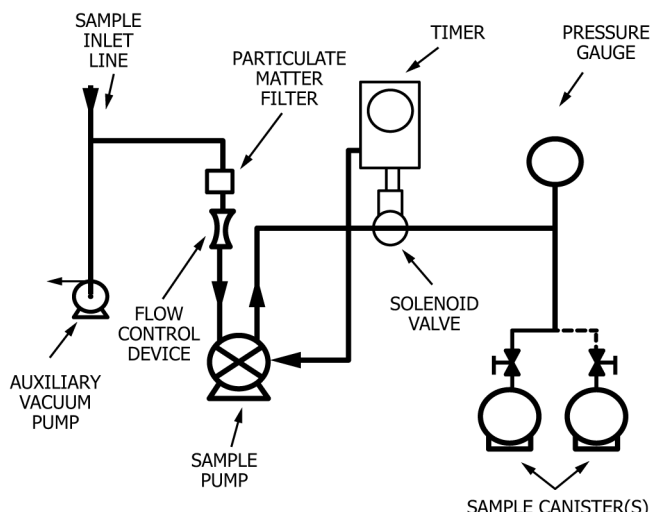
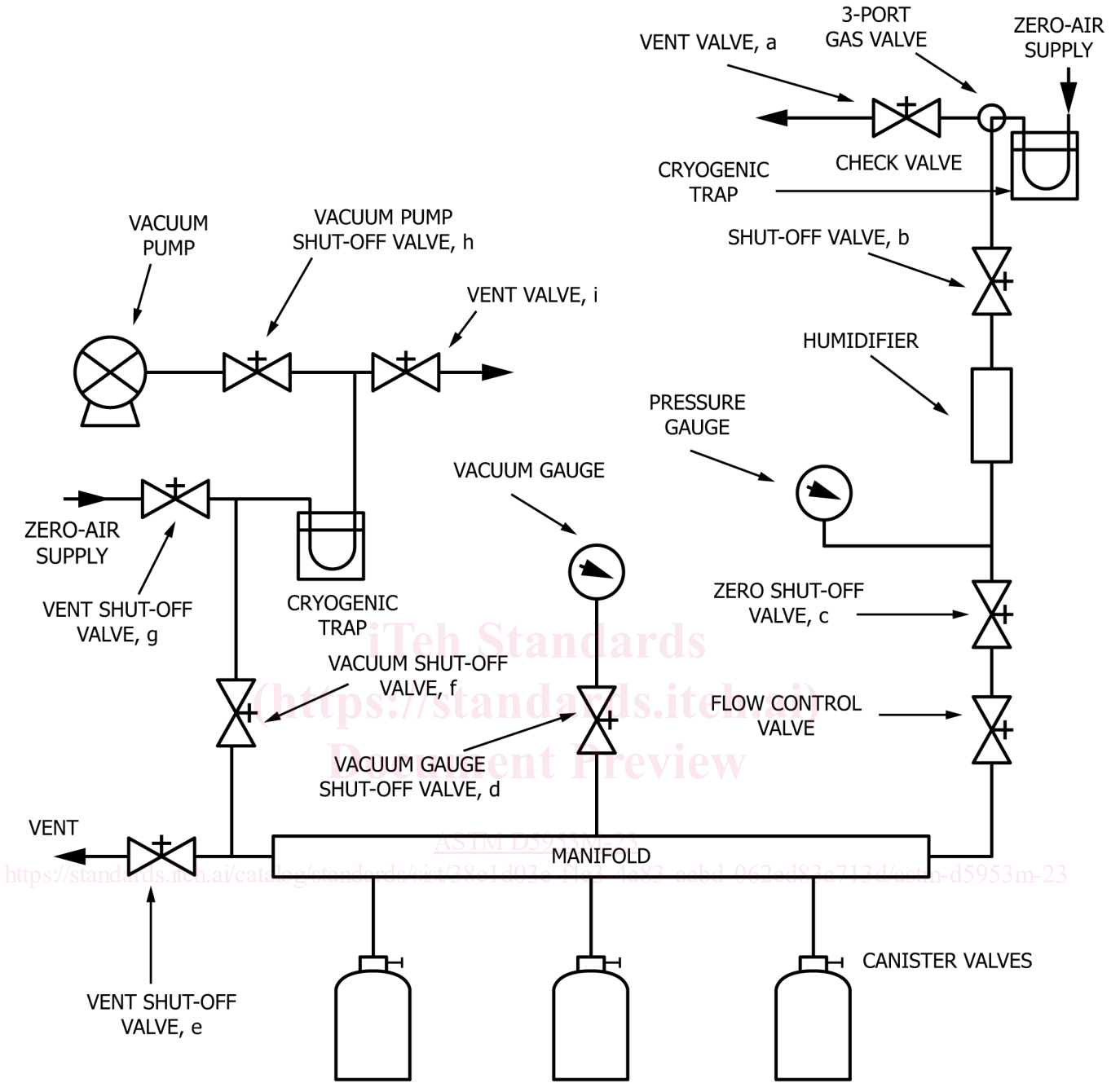

FIG. 1 Sample System for Automatic Collection of Integrated Air Samples



SAMPLE CANISTERS  
 FIG. 2 Canister Cleaning System

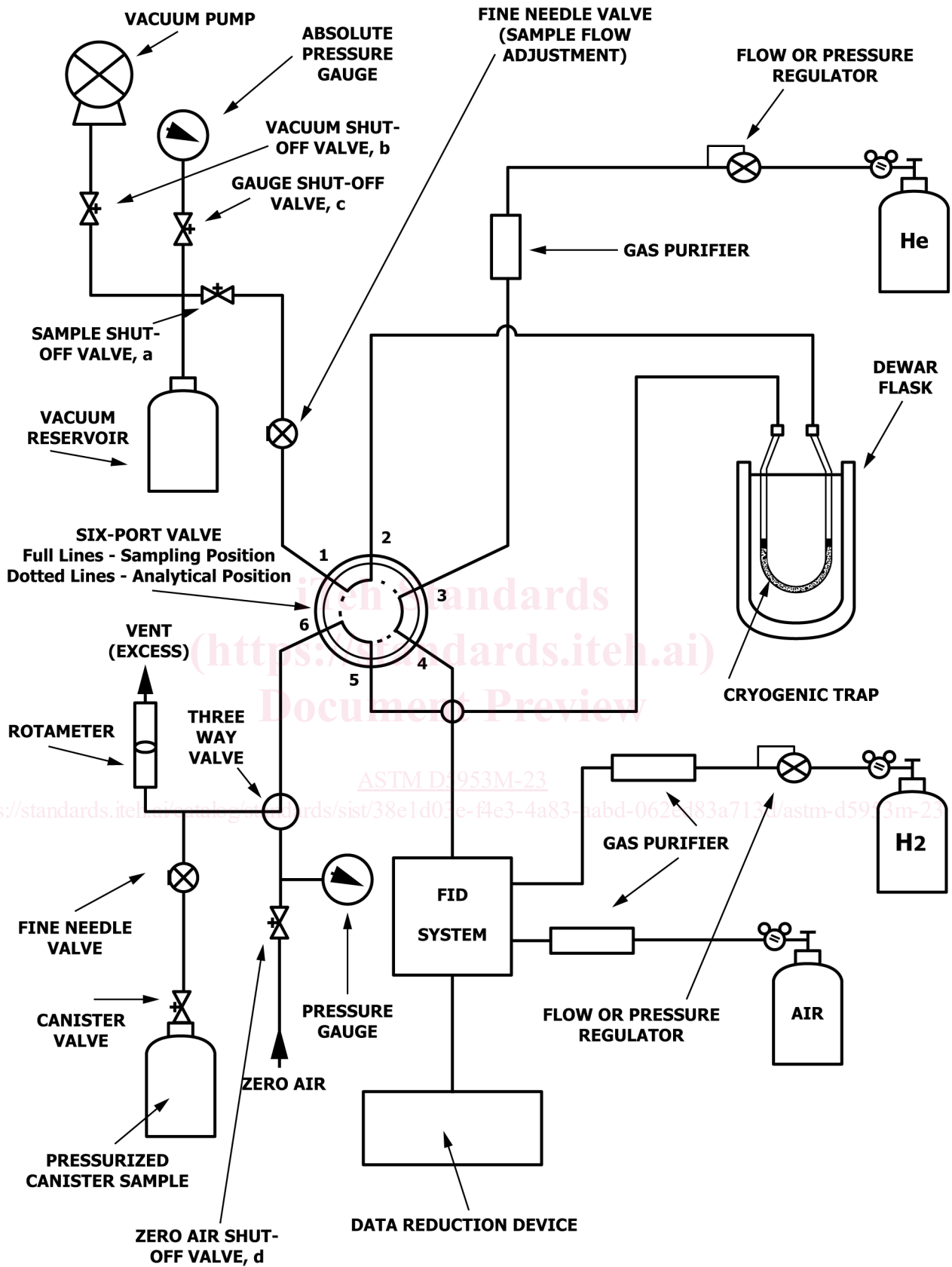

FIG. 3 NMOc Analytical System

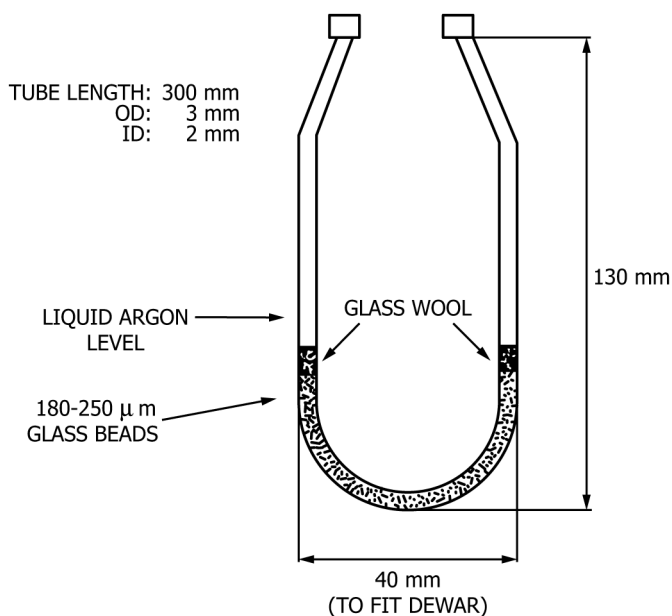

FIG. 4 Cryogenic Sample Trap

7.3.3.1 Pack the central portion of the trap (70 mm to 100 mm) with silanized 180  $\mu\text{m}$  to 250  $\mu\text{m}$  (60/80 mesh) glass beads, with small silanized glass wool plugs, to retain the beads.

7.3.3.2 The arms of the trap must be of such length to permit the beaded portion of the trap to be submerged below the level of cryogen in the Dewar flask.

7.3.3.3 Connect the trap directly to the six-port valve (7.3.4) to minimize the line length between the trap (7.3.3) and the FID (7.3.1).

7.3.3.4 Mount the trap to allow clearance so the Dewar flask may be applied and withdrawn to facilitate cooling and heating of the trap (see 7.3.12).

7.3.4 *Six-Port Valve*—Locate the six-port valve and as much of the interconnecting tubing as practical inside an oven or otherwise heat it to 90 °C to minimize wall losses or adsorption/desorption in the connecting tubing. All lines must be as short as practical.

NOTE 1—A diaphragm type valve is recommended for use, as standard rotational valves do not typically perform well in many applications of this test method.

7.3.5 *Multistage Pressure Regulators* (3 required), standard two-stage, stainless steel diaphragm regulators with pressure gauges, for helium, air, and hydrogen cylinders.

7.3.6 *Auxilliary Flow or Pressure Regulators* (2 required), to maintain constant flow rates, within 1 mL/min for the helium carrier and the hydrogen.

7.3.7 *Fine Needle Valve* (2 required)—One adjusts the sample flow rate through the trap, and the other adjusts the sample flow rate from the canister.

7.3.8 *Dewar Flask*, holds cryogen used to cool the trap, sized to contain the submerged portion of the trap.

7.3.9 *Absolute Pressure Gauge*, 0 kPa to 60 kPa (0 mm Hg to 450 mm Hg), with scale divisions of 0.25 kPa (2 mm Hg), monitors repeatable volumes of sample air through the cryogenic trap.

7.3.10 *Vacuum Reservoir*, 1 L to 2 L capacity, typically 1 L.

7.3.11 *Gas Purifiers* (3 required), gas scrubbers containing Drierite or silica gel and 5A molecular sieve to remove moisture and organic impurities in the helium, air, and hydrogen gas flow. Check the purity of the gas purifiers prior to use by passing zero-air through them and analyzing the gas in accordance with 11.4. The gas purifiers are clean if the NMOC concentration of the emitted gas is below the detection limit of the test method.

7.3.12 *Trap Heating System*, chromatographic oven, direct induction load heater, or other means to heat the trap to 90 °C at a controlled rate of 30 °C per minute.

7.3.12.1 Repeatable types of heat sources are recommended, including a temperature-programmed chromatograph oven, electrical heating of the trap itself, or any type of heater that brings the temperature of the trap up to 90 °C in 1 min to 2 min. This is not shown in Fig. 3.

7.3.13 *Toggle Shut-Off Valves* (4 required), must be leak free. Two are positioned on each side of the vacuum reservoir (7.3.10), one at the absolute pressure gauge (7.3.9), and one at the zero air cylinder (8.5) used for the analytical system leak test (10.1).

7.3.14 *Vacuum Pump*, general purpose laboratory oil-less diaphragm pump, must be capable of evacuating the vacuum reservoir (7.3.10) to allow the desired sample volume to be drawn through the trap.

7.3.15 *Vent*, to keep the trap at atmospheric pressure during trapping.

7.3.16 *Rotameter or Electronic Flow Measurement Device*, verifies that there is vent flow at all times during trapping.

7.3.17 *Three-Way Valve*.

7.3.18 *Chromatographic-Grade Stainless Steel Tubing and Fittings*, stainless steel tubing and fittings for interconnections.

7.3.18.1 All such materials in contact with the sample, analyte, or support gases prior to analysis must be of stainless steel or other inert metal.

7.3.18.2 Do not use plastic or TFE-fluorocarbon tubing or fittings.

7.3.19 *Pressure Gauge*, capable of reading up to 500 kPa (60 psig).

## 8. Reagents and Materials

8.1 **Warning**—Gas cylinders and compressed gas standards should only be handled in well-ventilated locations, away from sparks and flames. Improper handling of compressed gas cylinders containing air, nitrogen, hydrogen, or helium can result in explosion. Rapid release of nitrogen or helium can result in asphyxiation. Compressed air supports combustion. Hydrogen is highly flammable and burns with a colorless, transparent flame. Liquid argon is a freeze hazard as well as an asphyxiate.

8.2 *Gas Cylinders of Helium and Hydrogen*, ultrahigh purity grade.

8.3 *Combustion Air*, cylinder containing less than 0.02 ppm (v) hydrocarbons, or equivalent air source.

8.4 *Propane Calibration Standard*, cylinder containing 1 ppm to 100 ppm (v) (3 ppm to 300 ppm C) propane in air,

traceable to a National Institute of Standards and Technology (NIST) Standard Reference Material (SRM) or to a NIST/EPA-approved Certified Reference Material (CRM).

8.5 *Zero-Air*, cylinder containing less than or equal amounts of total hydrocarbons as the detection limit of the test method.

8.5.1 Zero-air may be obtained from a cylinder of zero-grade compressed air scrubbed with anhydrous calcium sulfate or silica gel and 5A molecular sieve or activated charcoal, or by catalytic cleanup of ambient air.

8.5.2 Pass the zero-air used for canister cleaning (9.3) through a cryogenic cold trap (7.2.5) for final cleanup, then through a hydrocarbon-free water (8.7) humidifier (7.2.8) (or other device).

8.6 *Cryogen* (bp  $-185.7\text{ }^{\circ}\text{C}$ ), liquid argon recommended.

8.6.1 If liquid argon cannot maintain the trap temperature at  $-185.7\text{ }^{\circ}\text{C}$  due to the location of the laboratory, such as at high altitudes (where the normal atmospheric pressure is less than 101.3 kPa), a mechanical refrigeration system can be used (see 13.5.1).

8.7 *Purity of Water*—Unless otherwise stated, water shall be Type II reagent water conforming to Specification D1193.

**9. Canister Cleanup and Preparation**

9.1 Leak test and clean the canisters (7.1.1) of contaminants before sample collection.

9.2 Leak test the canisters by pressurizing them to approximately 200 kPa above atmospheric pressure (30 psig) with zero-air (8.5), using the canister cleaning system (see Fig. 2).

9.2.1 Record the final pressure and close the canister valve, then check the pressure after 24 h. If leak-tight, the pressure will not have not dropped by more than 15 kPa (2 psig) over the 24-h period at constant temperature.

9.2.2 Record the leak check result on the Sampling Data Sheet, Fig. 5.

9.3 Clean the canister(s) as illustrated in Fig. 2.

9.3.1 Close all the valves.

9.3.2 Add cryogen (8.6) to both the vacuum pump and zero-air supply traps (7.2.5).

9.3.3 Connect the canister(s) (7.1.1) to the manifold (7.2.2). Open the vent shut-off valve (E) and the canister valve(s) to release any remaining pressure in the canister(s).

9.3.4 Now close the vent shut-off valve (E) and open the vacuum shut-off valve (D).

9.3.5 Energize the vacuum pump (7.2.1), open the vacuum shut-off valves F and H, and evacuate the canister(s) to  $\leq 1.69\text{ kPa}$  (29.5 in. Hg vacuum) for 30 min with optional heating to no more than  $100\text{ }^{\circ}\text{C}$  in an isothermal oven (7.2.9).

9.4 On a daily basis, or more often if necessary, blow out the cryogenic traps (7.2.5) with zero-air (8.5), using valves A and I, to remove trapped water from previous canister cleaning cycles.

9.5 Close the vacuum and vacuum gauge shut-off valves (H and D) and open the zero-air shut-off valves (B and C) to pressurize the canister(s) with moist zero-air (8.5) to approximately 200 kPa over atmospheric pressure (30 psig). Hold this

**PRESSURIZED CANISTER SAMPLING DATA SHEET**

**GENERAL INFORMATION**

PROJECT \_\_\_\_\_  
 SITE \_\_\_\_\_  
 LOCATION \_\_\_\_\_  
 MONITOR STATION NO. \_\_\_\_\_  
 PUMP SERIAL NO. \_\_\_\_\_

OPERATOR \_\_\_\_\_  
 ORIFICE NO. \_\_\_\_\_  
 FLOW RATE \_\_\_\_\_  
 CALIBRATED BY \_\_\_\_\_  
 LEAK CHECK \_\_\_\_\_

Pass                      Fail

**FIELD DATA**

| Date | Canister No. | Sample No. | Sample Time |      | Average Atmospheric Conditions  |               |       | Canister Pressure |            |          | Comments |
|------|--------------|------------|-------------|------|---------------------------------|---------------|-------|-------------------|------------|----------|----------|
|      |              |            | Start       | Stop | Temperature, $^{\circ}\text{C}$ | Pressure, kPa | RH, % | Initial, kPa      | Final, kPa | Lab, kPa |          |
|      |              |            |             |      |                                 |               |       |                   |            |          |          |
|      |              |            |             |      |                                 |               |       |                   |            |          |          |
|      |              |            |             |      |                                 |               |       |                   |            |          |          |

\_\_\_\_\_ Date

\_\_\_\_\_ Signature

\_\_\_\_\_ Title

Title

**FIG. 5 Example Sampling Data Sheet**