



Designation: ~~C1134 – 17~~^{e1} C1134 – 23

Standard Test Method for Water Retention of Rigid Thermal Insulations Following Partial Immersion¹

This standard is issued under the fixed designation C1134; the number immediately following the designation indicates the year of original adoption or, in the case of revision, the year of last revision. A number in parentheses indicates the year of last reappraisal. A superscript epsilon (ϵ) indicates an editorial change since the last revision or reappraisal.

^{e1} NOTE – Editorially corrected 6.1 in January 2022.

1. Scope

1.1 This test method determines the amount of water retained (including surface water) by rigid block and board thermal insulations used in building construction applications after these materials have been partially immersed in liquid water for prescribed time intervals under isothermal conditions. This test method is intended to be used for the characterization of materials in the laboratory. It is not intended to simulate any particular environmental condition potentially encountered in building construction applications.

1.2 This test method does not address all the possible mechanisms of water intake and retention and related phenomena for rigid thermal insulations. It relates only to those conditions outlined in 1.1. Determination of moisture accumulation in thermal insulations due to complete immersion, water vapor transmission, internal condensation, freeze-thaw cycling, or a combination of these effects requires different test procedures.

1.3 Each partial immersion interval is followed by a brief free-drainage period. This test method does not address or attempt to quantify the drainage characteristics of materials. Therefore, results for materials with different internal structure and porosity, such as cellular materials and fibrous materials, are not necessarily directly comparable. Also, test results for specimens of different thickness are not necessarily directly comparable because of porosity effects. The surface characteristics of a material also affect drainage. It is possible that specimens with rough surfaces will retain more surface water than specimens with smooth surfaces, and that surface treatment during specimen preparation will affect water intake and retention. Therefore, it is not advisable to directly compare results for materials with different surface characteristics.

1.4 For most materials the size of the test specimens is small compared with the size of the products actually installed in the field. If the surface-to-volume ratios for the test specimens and the corresponding products are different, it is possible that the test results will be misleading.

1.5 The values stated in SI units are to be regarded as standard. The values given in parentheses are mathematical conversions to inch-pound units that are provided for information only and are not considered standard.

1.6 *This standard does not purport to address all of the safety concerns, if any, associated with its use. It is the responsibility of the user of this standard to establish appropriate safety, health, and environmental practices and determine the applicability of regulatory limitations prior to use.*

¹ This test method is under the jurisdiction of ASTM Committee C16 on Thermal Insulation and is the direct responsibility of Subcommittee C16.33 on Insulation Finishes and Moisture.

Current edition approved Oct. 1, 2017/March 1, 2023. Published November 2017/March 2023. Originally approved in 1990. Last previous edition approved in 2012/2017 as C1134 – 90 (2012)/C1134 – 17^{e1}. DOI: 10.1520/C1134-17E01; 10.1520/C1134-23.

1.7 This international standard was developed in accordance with internationally recognized principles on standardization established in the Decision on Principles for the Development of International Standards, Guides and Recommendations issued by the World Trade Organization Technical Barriers to Trade (TBT) Committee.

2. Referenced Documents

2.1 ASTM Standards:

[C168 Terminology Relating to Thermal Insulation](#)²

[E691 Practice for Conducting an Interlaboratory Study to Determine the Precision of a Test Method](#)

3. Terminology

3.1 *Definitions*—Terminology [C168](#) applies to terms used in this test method.

3.2 *Descriptions of Terms Specific to This Standard:*

3.2.1 WR_S —short-term water retention rating.

3.2.2 WR_L —long-term water retention rating.

4. Significance and Use

4.1 Materials less than or equal to 15 mm (0.59 in.) in thickness shall not be tested in accordance with this test method in order to avoid complete immersion of the specimens. This type of exposure is beyond the scope of this test method.

4.2 This test method is used to assess both the short-term water retention and the long-term water retention. The short-term water retention is assessed as the average of the water retained following partial immersion intervals of 0.75-h and 3.00-h, in kilograms per square meter (percent by volume) (for materials tested at 25.4 mm (1.00 in.) thickness). The long-term water retention is assessed as the water retained following a 168-h partial immersion interval, in kilograms per square meter (percent by volume) (for materials tested at 25.4 mm (1.00 in.) thickness).

4.3 Materials shall be tested at both actual product thickness and 25.4 mm (1.00 in.) thickness provided the materials can be cut to a thickness of 25.4 mm (1.00 in.) without changing the original character of the materials. If a product cannot be cut without changing the original character of the material, the corresponding information shall be provided in the test report. Results shall be reported on the basis of equal nominal wetted specimen surface area (in units of kilograms per square meter) for materials tested at actual product thickness and on the basis of equal specimen volume (in units of percent by volume) for materials tested at 25.4 mm (1.00 in.) thickness. If a product cannot be cut to a thickness of 25.4 mm (1.00 in.) or if the actual product thickness is less than 25.4 mm (1.00 in.) but greater than 15 mm (0.59 in.), the product shall only be tested at actual product thickness and results only reported on the basis of equal nominal wetted specimen surface area.

4.3.1 By reporting results on the basis of equal nominal wetted specimen surface area, specimens of different thicknesses can be compared equitably. For some specimens, the water intake and retention primarily depends on the nominal wetted surface area available for water intake.

4.3.2 By reporting results on the basis of equal specimen volume, specimens can be compared equitably using units that commonly are selected to represent results of water intake testing (percent by volume). For some materials, water intake and retention primarily depends on the volume of the specimen available for water intake.

4.3.3 In most cases water retention is a secondary performance characteristic that has an influence on a primary performance characteristic, such as thermal performance, surface accumulation of moisture (that will potentially contribute to fungal growth), or localized collection of electrolytes (that will potentially contribute to corrosion). Depending on the primary performance characteristic that is of interest, the preferred units for use in comparing the water retention of different materials will be either kilograms per square meter or percent by volume.

4.4 Immersion times in addition to those required by this test method shall be permitted to be selected provided that all parties involved are in agreement.

² For referenced ASTM standards, visit the ASTM website, www.astm.org, or contact ASTM Customer Service at service@astm.org. For *Annual Book of ASTM Standards* volume information, refer to the standard's Document Summary page on the ASTM website.

4.5 The water retention characteristics of materials will potentially be affected by conditions such as elevated temperatures or chemical exposures.

5. Apparatus

5.1 *Test Chamber*—The test chamber or room where the test is to be run shall be maintained at a temperature of $23 \pm 2^\circ\text{C}$ ($73 \pm 4^\circ\text{F}$) and a relative humidity of $50 \pm 5\%$.

5.2 *Immersion Tank*—The immersion tank shall consist of an open tank of sufficient size to accommodate at least three specimens. Included in the construction of the tank shall be a means for securing the specimens in a level position, that is, a noncorrosive support for the bottom surface of the specimens and a similar constraining device for the top surface. The support and constraining devices shall not contact more than 15 % of the specimen surfaces. The pressure exerted on the specimens by the constraining device for the top surface shall be limited to that required to counteract any buoyant force exerted by the specimens at the beginning of the test. The immersion tank shall be provided with a water overflow level, as shown in Fig. 1.

5.3 *Balance*—The balance shall have a sensitivity of at least 0.1 g. For some measurements, such a sensitivity will be more than is required, in which case a sensitivity of at least 0.1 % of the total mass of the specimen after immersion and the weighing container is acceptable. See 7.4.1. To achieve these sensitivities, it is possible that two different balances will be required.

5.4 *Weighing Container*—The weighing container shall be made of a nonabsorbent, waterproof, lightweight material and shall be large enough to allow a specimen to be laid flat in the container.

5.5 *Linear Measuring Instrument*—The linear measuring instrument shall be capable of measuring specimen dimensions to the nearest 0.25 mm (0.01 in.).

5.6 *Distilled or Deionized Water*—Distilled or deionized water shall be used for testing.

5.7 *Drainage Rack*—The drainage rack shall be similar to that shown in Figs. 2 and 3.

6. Test Specimens

6.1 Six test specimens shall be selected randomly from each sample. Only three specimens are required if the product is only to be tested at the actual product thickness or if the actual product thickness is 5.4 mm (0.21 in.). See 4.3.

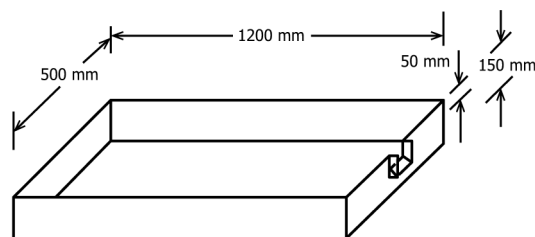

(a) Typical dimensions for an immersion tank

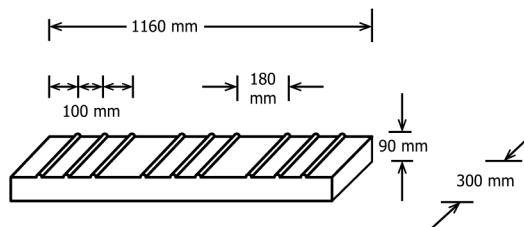

(b) Typical dimensions for a noncorrosive support for the specimens

FIG. 1 Immersion Tank

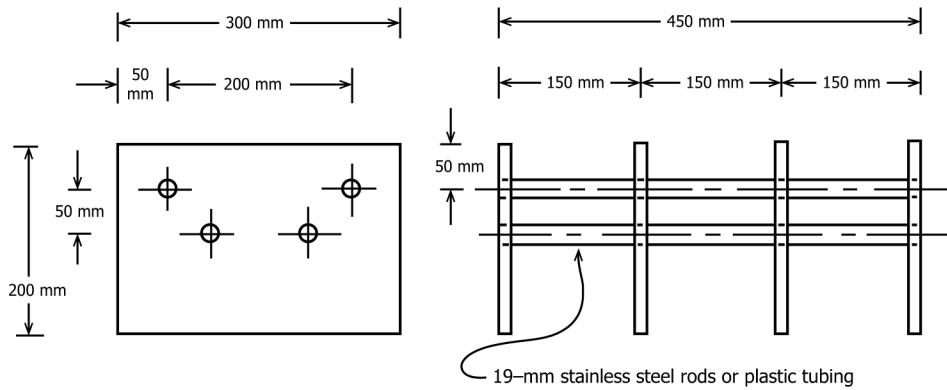

FIG. 2 Drainage Rack for Three Specimens

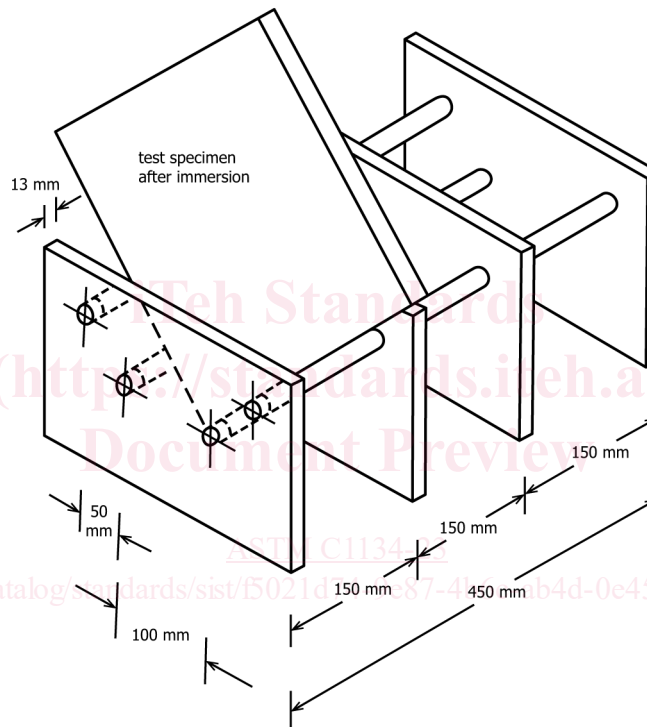

FIG. 3 Test Specimen in Drainage Rack

6.2 The test specimens shall be square with a length and width of 300 ± 10 mm (11.8 ± 0.4 in.). The thickness of three of the specimens shall be the same as that of the product or sample from which the specimens are taken. The thickness of the other three specimens shall be 25.4 ± 1.6 mm (1.00 ± 0.06 in.), provided the material is greater than 25.4 mm (1.00 in.) in thickness. Specimens shall be cut to this size from thicker stock if appropriate. See 4.3.

6.3 Specimen Preparation:

6.3.1 Materials normally produced with natural skins or specially cut surfaces shall be tested with at least one skin or surface intact, and that skin or surface shall be placed in contact with the water when the test is conducted. The corresponding information shall be provided in the test report.

6.3.2 Composite materials normally produced with facings or laminates shall be tested either with or without facings, as required by the appropriate material specification. The corresponding information shall be provided in the test report.

6.3.3 Ensure that no indentations are made when handling specimens. Any specimens having surface indentations greater than 5.0 mm (0.20 in.) in depth or any specimens damaged during preparation shall be rejected and replaced by new specimens prior to testing.

7. Procedure

7.1 Measure test specimen dimensions (length, l , width, w , and thickness, t) to the nearest 0.2 mm (0.01 in.). Measure both the length and width at three different locations and the thickness at nine different locations, as shown in Fig. 4. The average of each set of dimensions shall be used to calculate the volume, V , of the specimen.

7.2 Record the initial mass of each specimen to the nearest 0.1 g, and condition the specimens to constant mass in the laboratory at a temperature of $23 \pm 2^\circ\text{C}$ ($73 \pm 4^\circ\text{F}$) and a relative humidity of $50 \pm 5\%$. Allow at least 24 h for the initial conditioning period and then at least 4 h for each additional period as needed. Continue conditioning until specimens reach constant mass as indicated by a change in mass of 0.2 g or less between successive weighings. Record the dry mass, M_0 , of each specimen to the nearest 0.1 g.

7.3 Using nonabsorbent dummy blocks of the same size as the test specimens, adjust the support and constraining devices so that the dummy blocks are horizontal and level. Make certain that the immersion tank is also level. Adjust the water level in the immersion tank so that it is 10.0 ± 1.6 mm (0.39 ± 0.06 in.) above the bottom surface of the dummy blocks. Remove the dummy blocks and replace them with the actual test specimens. If necessary, add water to ensure that the specimens are immersed to the required depth. If the immersion tank is not provided with an automatic adjustment for the water level, add water at least once during each 24-h period to ensure that the specimens are immersed to the required depth.

7.4 Remove and weigh the specimens at the following time intervals: 0.75 ± 0.03 h, 3.00 ± 0.15 h, and 168 ± 4 h. These times are required. Use longer or intermediate immersion times as needed to provide more information.

7.4.1 Determine the mass of the weighing container to the nearest 0.1 g. Place each specimen on the drainage rack, as shown in Fig. 3. Allow 6.0 ± 0.5 min. for the drainage of water. Remove each specimen from the drainage rack and place it in the weighing container with the wet side down. Weigh each specimen and its container to the nearest 0.1 g or to within 0.1 % of the total mass of the specimen and the weighing container. (Choose the sensitivity that is largest in magnitude or most convenient to use.) Subtract the mass of the weighing container from the total mass, and record the mass of each specimen in grams to the appropriate

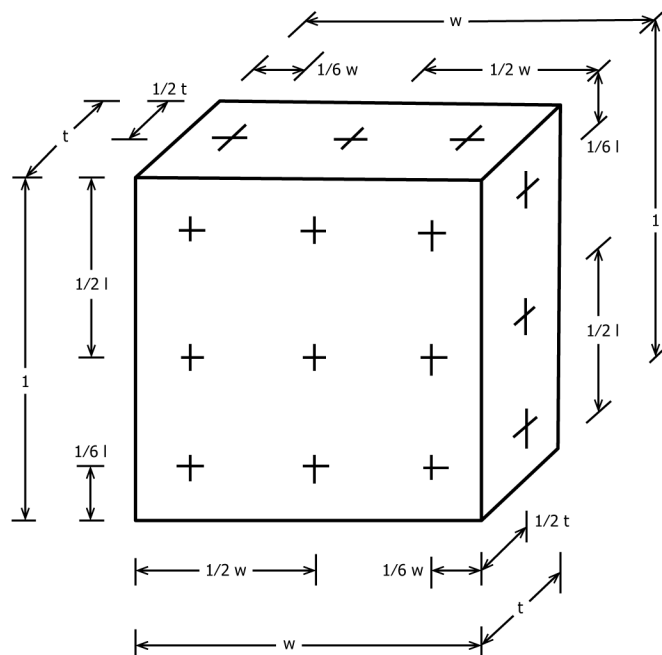

FIG. 4 Measurement Locations for Determining Test Specimen Dimensions

sensitivity. Data shall be clearly identified by the letter M_t with the subscript indicating the immersion time, for example $M_{0.75}$ for the mass after a 0.75-h immersion time. Clean and dry the weighing container if it is going to be reused, and reweigh it before proceeding with the next specimen.

7.4.2 Return the specimens to the immersion tank, making sure each specimen is placed in the tank with the wet side down. Total time elapsed between removal and return of the specimens shall not be longer than 8 min.

7.4.3 Repeat the procedures given in 7.4.1 and 7.4.2 for each immersion time.

8. Calculation

8.1 Calculate the nominal wetted surface area, A , of each specimen from the average dimensions measured in accordance with 7.1 and from the depth to which the specimens are immersed as follows:

$$A = \frac{(1 \cdot w) + 2d(l + w)}{1000000} \quad (1)$$

where:

A = nominal wetted surface area of the specimen, m^2 ,
 l = length of the specimen, mm,
 w = width of the specimen, mm, and
 d = depth at which the specimens are immersed, mm.

8.2 Calculate the volume, V , of each specimen from the average dimensions measured in accordance with 7.1 as follows:

$$V = \frac{l \cdot w \cdot t}{1000} \quad (2)$$

where:

V = volume of the specimen, cm^3 , and
 t = thickness of the specimen, mm.

8.3 Calculate the water retention, WR_t , for each immersion time, t , as shown in 8.3.1 and 8.3.2.

8.3.1 For each specimen calculate the water retention ($WR_{t(kg/m^2)}$), expressed in kilograms per square meter, for each immersion time, t , as follows:

$$WR_{t(kg/m^2)} = \frac{M_t - M_0}{A \cdot 1000} \quad (3)$$

where:

$WR_{t(kg/m^2)}$ = water retention of the specimen for time, t , kg/m^2 ,
 M_t = mass of the specimen after immersion time, t , g, and
 M_0 = mass of the conditioned specimen, g.

8.3.2 For each specimen tested at a thickness of 25.4 mm (1.00 in.), calculate the water retention, $WR_{t(\%)}$, expressed in percent by volume, for each immersion time, t , as follows:

$$WR_{t(\%)} = \frac{M_t - M_0}{V} \cdot 100 \quad (4)$$

where:

$WR_{t(\%)}$ = water retention of the specimen for time, t , percent by volume.

NOTE 1—The density of water is assumed to be 1.00 g/cm^3 at 23°C (73°F).

8.4 Calculate the short-term water retention rating, WR_s , for each specimen, expressed in kilogram per square meter and percent

by volume (for materials tested at 25.4 mm (1.00 in.) thickness) by averaging the water retention for the 0.75-h and 3.00-h partial-immersion intervals, determined for each specimen in accordance with 8.3, as follows:

$$WR_{S(\text{kg/m}^2)} = \frac{WR_{0.75(\text{kg/m}^2)} + WR_{3(\text{kg/m}^2)}}{2} \quad (5)$$

where:

$WR_{S(\text{kg/m}^2)}$ = short-term water retention rating of the specimen, kg/m^2 .

$$WR_{S(\%)} = \frac{WR_{0.75(\%)} + WR_{3(\%)}}{2} \quad (6)$$

where:

$WR_{S(\%)}$ = short-term water retention rating of the specimen, percent by volume.

8.5 Record the long-term water retention rating, WR_L , for each specimen, expressed in kilograms per square meter and percent by volume (for materials tested at 25.4 mm (1.00 in.) thickness) as indicated in 8.3, as follows:

$$WR_{L(\text{kg/m}^2)} = WR_{168(\text{kg/m}^2)} \quad (7)$$

where:

$WR_{L(\text{kg/m}^2)}$ = long-term water retention rating of the specimen, kg/m^2 .

$$WR_{L(\%)} = WR_{168(\%)} \quad (8)$$

where:

$WR_{L(\%)}$ = long-term water retention rating of the specimen, percent by volume.

8.6 Calculate the density, D , of each conditioned specimen tested at actual product thickness as follows:

$$D = \frac{M_0}{V} \cdot 1000 \quad (9)$$

where: <https://standards.iteh.ai/catalog/standards/sist/f5021d74-9e87-4b6c-ab4d-0e45527e3b80/astm-c1134-23>

D = density of the specimen, kg/m^3 .

9. Report

9.1 The report shall include the following information about the specimens:

9.1.1 Identification of the specimens by material type, manufacturer, and lot number.

9.1.2 Date and location of testing.

9.1.3 Description of the specimens tested, including whether the material is produced with natural skins, facings, or laminates, and specimen thickness.

9.1.4 Required information that relates to items addressed in 4.3 and 6.3.

9.2 The report shall contain the following results:

9.2.1 Short-term water retention ratings and long-term water retention ratings, that is, WR_S and WR_L , respectively, expressed in kilograms per square meter and percent by volume (for materials tested at 25.4 mm (1.00 in.) thickness) for each specimen and the averages.

9.2.2 Any observations as to warping, cracking, or change in appearance of the specimens during the test or drying period.