



Designation: **F2887--17 F2887 - 23**

Standard Specification for Total Elbow Prostheses¹

This standard is issued under the fixed designation F2887; the number immediately following the designation indicates the year of original adoption or, in the case of revision, the year of last revision. A number in parentheses indicates the year of last reapproval. A superscript epsilon (ϵ) indicates an editorial change since the last revision or reapproval.

1. Scope

1.1 This specification covers total elbow replacement (TER) prostheses and hemi-elbow replacement (“hemi”) prostheses used to provide functioning articulation by employing humeral, ulnar, and/or radial components that allow for the restoration of motion of the human elbow joint complex.

1.2 Included within the scope of this specification are elbow prosthesis components for primary and revision surgery with linked and non-linked designs and components implanted with or without use of bone cement.

1.3 This specification is intended to provide basic descriptions of material and prosthesis geometry. In addition, those characteristics determined to be important to the *in vivo* performance of the prosthesis are defined. However, compliance with this specification does not itself mean that a device will provide satisfactory clinical performance.

1.4 The values stated in SI units are to be regarded as standard. No other units of measurement are included in this standard.

1.5 *This international standard was developed in accordance with internationally recognized principles on standardization established in the Decision on Principles for the Development of International Standards, Guides and Recommendations issued by the World Trade Organization Technical Barriers to Trade (TBT) Committee.*

2. Referenced Documents

2.1 ASTM Standards:²

- F75 Specification for Cobalt-28 Chromium-6 Molybdenum Alloy Castings and Casting Alloy for Surgical Implants (UNS R30075)
- F86 Practice for Surface Preparation and Marking of Metallic Surgical Implants
- F90 Specification for Wrought Cobalt-20Chromium-15Tungsten-10Nickel Alloy for Surgical Implant Applications (UNS R30605)
- F136 Specification for Wrought Titanium-6Aluminum-4Vanadium ELI (Extra Low Interstitial) Alloy for Surgical Implant Applications (UNS R56401)
- F451 Specification for Acrylic Bone Cement
- F565 Practice for Care and Handling of Orthopedic Implants and Instruments
- F648 Specification for Ultra-High-Molecular-Weight Polyethylene Powder and Fabricated Form for Surgical Implants
- F732 Test Method for Wear Testing of Polymeric Materials Used in Total Joint Prostheses

¹ This test method specification is under the jurisdiction of ASTM Committee F04 on Medical and Surgical Materials and Devices and is the direct responsibility of Subcommittee F04.22 on Arthroplasty.

Current edition approved Jan. 1, 2017; March 1, 2023. Published March 2017; March 2023. Originally approved in 2012. Last previous edition approved in 2012 as F2887F2887 - 17, -12. DOI: 10.1520/F2887-17.10.1520/F2887-23.

² For referenced ASTM standards, visit the ASTM website, www.astm.org, or contact ASTM Customer Service at service@astm.org. For *Annual Book of ASTM Standards* volume information, refer to the standard's Document Summary page on the ASTM website.

- F746 Test Method for Pitting or Crevice Corrosion of Metallic Surgical Implant Materials
- F748 Practice for Selecting Generic Biological Test Methods for Materials and Devices
- F799 Specification for Cobalt-28 Chromium-6 Molybdenum Alloy Forgings for Surgical Implants (UNS R31537, R31538, R31539)
- F983 Practice for Permanent Marking of Orthopaedic Implant Components
- F1044 Test Method for Shear Testing of Calcium Phosphate Coatings and Metallic Coatings
- F1108 Specification for Titanium-6Aluminum-4Vanadium Alloy Castings for Surgical Implants (UNS R56406)
- F1147 Test Method for Tension Testing of Calcium Phosphate and Metallic Coatings
- F1160 Test Method for Shear and Bending Fatigue Testing of Calcium Phosphate and Metallic Medical and Composite Calcium Phosphate/Metallic Coatings
- F1223 Test Method for Determination of Total Knee Replacement Constraint
- F1377 Specification for Cobalt-28Chromium-6Molybdenum Powder for Medical Devices (UNS R30075, UNS R31537, and UNS R31538)
- F1472 Specification for Wrought Titanium-6Aluminum-4Vanadium Alloy for Surgical Implant Applications (UNS R56400)
- F1537 Specification for Wrought Cobalt-28Chromium-6Molybdenum Alloys for Surgical Implants (UNS R31537, UNS R31538, and UNS R31539)
- F1580 Specification for Titanium and Titanium-6 Aluminum-4 Vanadium Alloy Powders for Coatings of Surgical Implants
- F1814 Guide for Evaluating Modular Hip and Knee Joint Components
- F2759 Guide for Assessment of the Ultra-High Molecular Weight Polyethylene (UHMWPE) Used in Orthopedic and Spinal Devices

2.2 ISO Standards:³

- ISO ~~5832-3~~5832-3 Implants for Surgery—Metallic Materials—Part 3: Wrought Titanium 6-Aluminum 4-Vandium Alloy
- ISO ~~5832-4~~5832-4 Implants for Surgery—Metallic Materials—Part 4: Cobalt-Chromium-Molybdenum Casting Alloy
- ISO ~~5832-12~~5832-12 Implants for Surgery—Metallic Materials—Part 12: Wrought Cobalt-Chromium-Molybdenum Alloy
- ISO ~~5834-2~~5834-2 Implants for Surgery—Ultra High Molecular Weight Polyethylene—Part 2: Moulded Forms
- ISO 6018 Orthopaedic Implants—General Requirements for Marking, Packaging, and Labeling
- ISO ~~10993-1~~10993-1 Biological Evaluation of Medical Devices—Part 1: Evaluation and Testing Within a Risk Management Process
- ISO ~~14243-1~~14243-1 Implants for Surgery—Wear of Total Knee-Joint Prostheses—Part 1: Loading and Displacement Parameters for Wear-testing Machines with Load Control and Corresponding Environmental Conditions for Test
- ISO ~~14243-2~~14243-2 Implants for Surgery—Wear of Total Knee-joint Prostheses—Part 2: Methods of Measurement
- ISO ~~14243-3~~14243-3 Implants for Surgery—Wear of Total Knee-joint Prostheses—Part 3: Loading and Displacement Parameters for Wear-testing Machines with Displacement Control and Corresponding Environmental Conditions for Test

2.3 FDA Documents:⁴

- 21 CFR 888.3150 Elbow Joint Metal/Polymer Constrained Cemented Prosthesis
- 21 CFR 888.3160 Elbow Joint Metal/Polymer Semi-constrained Cemented Prosthesis
- 21 CFR 888.3170 Elbow Joint Radial (Hemi-elbow) Polymer Prosthesis
- 21 CFR 888.3180 Elbow Joint Humeral (Hemi-elbow) Metallic Uncemented Prosthesis
- 21 CFR 888.6 Degree of Constraint
- ~~Guidance Document for Testing Orthopedic Implants~~ Guidance Document for Testing Orthopedic Implants with Modified Metallic Surfaces Apposing Bone or Bone Cement
- Guidance for Industry on the Testing of Metallic Plasma Sprayed Coatings on Orthopedic Implants to Support Reconsideration of Postmarket Surveillance Requirements
- ~~Guidance Document for Testing Non-articulating~~ Guidance Document for Testing Non-articulating, Mechanically Locked Modular Implant Components
- ~~Class II Special Controls Guidance Document~~ Document Knee Joint Patellofemorotibial and Femorotibial Metal/Polymer Porous-Coated Uncemented Prostheses; Guidance for Industry and FDA

2.4 ANSI/ASME Standard:³

- ANSI/ASME ~~B46.1-1995~~B46.1-1995 Surface Texture (Surface Roughness, Waviness, and Lay)

3. Terminology

3.1 Definitions of Terms Specific to This Standard:

3.1.1 *bearing surface, n*—part of the prosthetic component that articulates against the counter surface of the natural or prosthetic elbow joint.

³ Available from American National Standards Institute (ANSI), 25 W. 43rd St., 4th Floor, New York, NY 10036, <http://www.ansi.org>.

⁴ Available from Food and Drug Administration (FDA), 10903 New Hampshire Ave., Silver Spring, MD 20993-0002, <http://www.fda.gov>.

- 3.1.2 *extension, n*—rotation of the ulna and radius away from the humerus around the elbow joint axis in the sagittal plane.
- 3.1.3 *flexion, n*—rotation of the ulna and radius towards the humerus around the elbow joint axis in the sagittal plane.
- 3.1.4 *hemi-elbow replacement (hemi), n*—prosthetic part that substitutes for the natural humero-ulnar, ~~radio-ulnar~~radio-ulnar, and/or humero-radial articulating surfaces in the human elbow in which only one half of the articulating surfaces is replaced. The prosthesis is expected to articulate with the remaining natural biological surface(s).
- 3.1.5 *humeral component, n*—component fixed to the humerus for articulation with the natural or prosthetic ulnar and/or radial component(s), typically consisting of two major components: a fixation stem, and a bearing surface.
- 3.1.6 *interlock, n*—mechanical design feature used to increase the capture of one component within another to restrict unwanted displacement between components (that is, locking mechanism for modular components such as a bearing surface to a metallic stem component).
- 3.1.7 *laxity, n*—intentional looseness in the fit between linked style elbow prosthetic components (typically the humero-ulnar components) that allows small, secondary out-of-plane motions during primary motion to avoid a “fully constrained” or “rigid” connection.
- 3.1.8 *linked, n*—a style of total elbow prosthesis in which the humeral and ulnar components are physically connected by a linking mechanism to prevent disassociation (dislocation) while allowing motion in selected directions.
- 3.1.9 *non-linked, n*—a style of total elbow prosthesis in which the humeral and ulnar components are not physically connected by a linking mechanism. These components rely on soft tissue or another mechanism to minimize the potential for disassociation (dislocation) of the two components.
- 3.1.10 *pronation, n*—rotation of the radius medially about the ulna around a superior-inferior axis.
- 3.1.11 *radial component, n*—component fixed to the radius for articulation with the natural or prosthetic humeral and/or ulnar component(s), typically consisting of two major components: a fixation stem and a bearing surface.
- 3.1.12 *subluxation, n*—instability or partial dislocation which occurs when the relative translational or rotational motion between the humeral and ulnar components reaches an extreme where the two components would cease to articulate over the designated low-friction bearing surfaces.
- 3.1.13 *supination, n*—rotation of the radius laterally about the ulna around a superior-inferior axis.
- 3.1.14 *total elbow replacement (TER), n*—prosthetic parts that substitute for, at a minimum, the natural opposing humeral and ulnar articulating surfaces in the human elbow. This includes both humero-ulnar type devices that are intended to function with or without the natural radial head and humero-ulnar with humero-radial option type devices that are intended to replace all three natural articular surfaces of the elbow.
- 3.1.15 *ulnar component, n*—component fixed to the ulna for articulation with the natural or prosthetic humeral and/or radial component(s), typically consisting of two major components: a fixation stem and a bearing surface.
- 3.1.16 *valgus, n*—deviation of the ulna away from the midline of the body in the frontal plane.
- 3.1.17 *varus, n*—deviation of the ulna towards the midline of the body in the frontal plane.

4. Classification

4.1 The following classification by degree of constraint is suggested for all total joint prostheses including total elbow replacement

systems based on the concepts adopted by the U.S. Food and Drug Administration (21 CFR 888.6, 21 CFR 888.3150, 21 CFR 888.3160, 21 CFR 888.3170, 21 CFR 888.3180; see 2.3).

4.1.1 *Constrained*—A “constrained” joint prosthesis is used for joint replacement and prevents dislocation of the prosthesis in more than one anatomic plane and consists of either a single, flexible, across-the-joint component or more than one component linked together or affixed.

4.1.2 ~~*Semi-constrained*~~—*Semi-Constrained*—A “semi-constrained” joint prosthesis is used for joint replacement and limits translation and rotation of the prosthesis in one or more planes via the geometry of its articulating surfaces. It has no across-the-joint linkage.

4.1.3 Currently, most TERs are considered either semi-constrained or constrained. However, devices within a particular classification may allow various degrees of freedom (that is, translation(s) and rotation(s)). Currently, TERs which contain a linkage mechanism are classified as “constrained” per 4.1.1 yet these devices are often referred to as “sloppy hinge” or “linked, semi-constrained” in the peer-reviewed literature in reference to the laxity built into the linkage mechanism to prevent a completely constrained (rigid) connection. These types of devices allow some amount of varus/valgus and rotary motion between the humeral and ulnar components in addition to the primary flexion/extension motion. Devices without this additional laxity are often referred to as “fully constrained” in the literature. See X2.4 for additional discussion.

5. Material

5.1 The choice of materials is understood to be a necessary but not sufficient assurance of function of the device made from them. All devices conforming to this specification shall be fabricated from materials with adequate mechanical strength, durability, corrosion resistance, biocompatibility, and wear resistance.

5.1.1 *Mechanical Strength*—Various metallic components of elbow replacement devices have been successfully fabricated from materials, as examples, found in ASTM Specifications F75, F90, F136, F799, F1108, F1377, F1472, and F1537 and ISO 5832-3:5832-3. Polymeric bearing components have been fabricated from ~~ultra-high-molecular-weight~~ ~~ultra-high-molecular-weight~~ polyethylene (UHMWPE) as an example, as specified in Specification F648, Guide F2759, or ISO ~~5834-2:5834-2~~. Porous coatings have been fabricated from example materials specified in Specifications F75, F136, F1377, and F1580. Not all of these materials may possess sufficient mechanical strength for critical, highly stressed components or for articulating surfaces. Conformances of a selected material to its standard and successful clinical usage of the material in a previous implant design are not sufficient to ensure the strength of an implant. Manufacturing processes and implant design can strongly influence material properties and performance. Therefore, regardless of the material selected, the elbow prosthesis shall meet the performance requirements of Section 6 of this specification.

5.1.2 *Corrosion Resistance*—Materials with limited or no history of successful use for orthopaedic implant application shall be determined to exhibit corrosion resistance equal to or better than one of the materials listed in 5.1.1 when tested in accordance with Test Method F746. If the corrosion resistance of a material is less than one of the materials listed in 5.1.1 when tested in accordance to Test Method F746, its use shall be justified.

5.1.3 *Biocompatibility*—The biocompatibility of materials used shall be evaluated using a ~~risk-based~~ ~~risk-based~~ approach such as that outlined in ISO ~~10993-1:10993-1~~. Practice F748 or ISO 10993 provide guidance on types of biologic tests to perform on materials.

5.1.4 *Friction Characteristics*—Bearing surface material couples with limited or no history of successful use for orthopaedic implant application shall be determined to exhibit equal or better performance than one of the material couples listed in 5.1.1 when tested in a pin-on-flat or pin-on-disk test apparatus such as described in Test Method F732 with adequate controls for comparison. A number of different load levels may be used to cover the range of anticipated stresses between articulating components.

NOTE 1—Clinically successful elbow prostheses have utilized either CoCrMo alloy or Ti alloy articulating against UHMWPE. The wear behavior of Ti alloy articulating against UHMWPE in the presence of a third body (for example, bone or bone cement particles) has been demonstrated to be less than that of CoCrMo alloy articulating against UHMWPE under similar conditions. Therefore, appropriate surface treatments of the Ti alloy surface should be considered to improve wear performance of a Ti alloy/UHMWPE bearing couple in the presence of a third body as described in Section 7-J of Class II Special Controls Guidance Document: Knee Joint Patellofemoral and Femorotibial Metal/Polymer Porous-Coated Uncemented Prostheses; Guidance for Industry and FDA.

6. Performance Requirements

6.1 *Component Function*—Each component for total elbow replacement or hemi-elbow replacement is expected to function as intended when manufactured in accordance with good manufacturing practices and to the requirements of this specification. The components shall be capable of withstanding anticipated static and dynamic physiologic loads without compromising their function for the intended use and biological environment (**1-41, 2, 3, 4**).⁵ All components used for experimental measures of performance shall be equivalent to the finished product in form and material. Components shall be sterilized if it will affect their performance.

NOTE 2—Computer models may be used to evaluate many of the functional characteristics if appropriate material properties and functional constraints are included and the computer models have been validated with experimental tests.

NOTE 3—No recognized consensus test methodologies for TER yet exist. Implant testing should reflect current clinical failures and potential failure modes particular to the implant. To facilitate such testing, several references on elbow prostheses including bench testing methods reported in the peer-reviewed literature have been compiled. In the design of elbow implants, this background information may be helpful in determining worst-case elbow joint forces. However, these joint reaction forces are based upon limited available data of the forces and moments in the healthy elbow and include assumptions to address gaps in understanding. In order to generate pass/fail criteria (that is, forces, angles, and number of cycles) for a particular elbow prosthesis, one should take into consideration the anticipated patient population, worst-case physiological loads and angles, an appropriate safety factor, the potential for unsupported surfaces, and include in the final report all assumptions made in developing the test methodology.

6.1.1 *In-Vivo Loading Profiles*—Kincaid and An published a literature review of humeral-ulnar (HU) biomechanics that includes discussions around basic biomechanics, deriving ~~Joint Reaction Forces~~ joint reaction forces (JRF), types of ~~Activities of Daily Living~~ activities of daily living (ADL), and frequency of motions. From these data, they propose scalable *in-vitro* loading profiles for bench testing purposes (**4**).

6.1.2 *Stem Fracture*—Stem fracture has been reported clinically (**5-9**). Individual humeral, ulnar, and radial components should be fatigue tested using relevant or analogous test methods under appropriate loading conditions (that is, should consider worst-case scenarios) to address loss of supporting foundation leading to potential deformation and/or component fracture. One such bench testing methodology is described in Vardarajan et al. (**10**).

6.1.3 *Link Disassembly*—Linked implant disassembly has been reported clinically (**8, 9, 11-14, 12, 13, 14**). Assembled (linked) humeral and ulnar components should be tested using relevant or analogous test methods under appropriate loading conditions (that is, considering worst-case scenarios) to address loss of constraint leading to component fracture and/or disassembly. One such bench testing methodology is described in Vardarajan et al. (**14**).

6.1.4 *Subluxation*—Unlinked implant subluxation has been reported clinically (**8, 9**). Subluxation resistance of assembled components (that is, dislocation safety factor) should be measured and documented.

6.1.5 *Wear*—Bearing surface component wear, delamination, and fracture have been reported clinically (**6, 8, 9, 12-17**). Bearing components shall be analyzed or tested considering worst-case scenarios to demonstrate that the component can withstand anticipated physiological loading conditions and is not susceptible to the failure modes that have been reported in the literature. The worst-case scenarios should take into consideration loads, component sizes, thickness of the polymer bearing component, bony support, locking mechanism, edge loading, misalignments, and how these can affect the individual design. One such bench testing methodology is described in Kincaid et al. (**18**).

NOTE 4—In situations in which the pin-on-flat test may not be considered appropriate, other tests (for example, simulation of elbow prostheses wear performance testing similar to those described in ISO 14243-1, -2, -3 (parts 1-3) 14243-1, -2, -3 (parts 1 to 3) for knee prostheses) may be considered.

6.2 *Integrity of Modular Connections*—All modular components shall be evaluated for the integrity of their connecting mechanisms per the guidance provided in Guidance Document for Testing ~~Non-articulating, Non-Articulating~~ Mechanically Locked Modular Implant Components. As suggested in Guide F1814, static and dynamic shear tests, bending tests, and tensile tests or any combination may be necessary to determine the performance characteristics. The connecting mechanisms shall show sufficient integrity for the range of loads anticipated for the application. Alternatively, a “construct fatigue” or “durability” test may be performed to demonstrate integrity of a modular system in its entirety. Such a test shall simulate worst-case scenarios to demonstrate that the assembled component(s) are able to withstand anticipated physiological loading conditions and are not susceptible to the failure modes that have been reported in the literature. The worst-case scenarios should take into consideration patient activity levels, loads, component sizes, component misalignment, thickness of bearing inserts, bony support, locking

⁵ The boldface numbers in parentheses refer to a list of references at the end of this standard.

mechanism, edge loading, contact of dissimilar metals with respect to the potential for galvanic corrosion and/or mechanically assisted crevice corrosion (MACC) and how these factors can affect the performance of the design. One such “construct fatigue” bench testing methodology is described in Kincaid et al. (19).

6.3 *Coatings*—Porous metal coatings shall be evaluated per the guidance provided in Guidance Document for Testing Orthopedic Implants with Modified Metallic Surfaces Adjoining Bone or Bone Cement or Guidance for Industry on the Testing of Metallic Plasma Sprayed Coatings on Orthopedic Implants to Support Reconsideration of Postmarket Surveillance Requirements. Components shall be tested in accordance with Test Method F1044 (shear strength) and Test Method F1147 (tensile strength) and the average for each test should exceed 20 MPa. The fatigue properties may be evaluated in accordance with Test Method F1160.

6.4 *Range of Motion*—The prosthesis shall allow for a minimum range of motion (ROM) for both intended, primary degrees of freedom; ~~flexion-extension~~flexion-extension; and pronation-supination. These measurements apply to components mounted in neutral alignment in bone or in an anatomically representative substitute. It is critical to define the location of the neutral alignment position in terms of dimensions of the components. The initial positioning or location of the neutral alignment point will affect the range of motion values for certain TER prostheses. See Fig. 1, Fig. 2, and Appendix X1.

6.4.1 The prosthesis shall allow a minimum ROM of 0° (full extension) to 140° (full flexion) in flexion/extension motion (1, 2).

6.4.2 The prosthesis components shall allow a global ROM of pronation-supination of 170° (for example, 85° pronation/85° supination from the neutral forearm position) (1, 2).

6.5 *Laxity*—The prosthesis shall allow for a minimum amount of laxity in all secondary, passive degree of freedom planes. These measurements apply to components mounted in neutral alignment in bone or in an anatomically representative substitute. It is critical to define the location of the neutral alignment position in terms of dimensions of the components. The initial positioning or location of the neutral alignment point will affect the range of motion values for certain TER prostheses. See Fig. 1, Fig. 2, and X2.4.

6.5.1 The prosthesis shall allow a minimum of $\pm 3.5^\circ$ medial-lateral (varus-valgus) displacement (“laxity”) between the humero-ulnar components (3).

6.5.2 The prosthesis shall allow a minimum of 0.5 mm of displacement between the humero-ulnar components in the anterior-posterior and superior-inferior directions.

6.5.3 The prosthesis shall allow a minimum of $\pm 2^\circ$ of internal-external rotary displacement between the humero-ulnar components.

6.6 *Constraint*—TER prosthesis constraint data for the humero-ulnar or humero-radial articulations in the medial-lateral (varus-valgus), ~~anterior-posterior~~anterior-posterior, and internal-external rotation (pronation-supination) directions may also be determined in a similar manner as described in Test Method F1223 for total knee replacement components.

7. Dimensions

7.1 Dimensions of TER components may be designated in accordance with Fig. 1 (“linked” type implant) and/or Fig. 2 (“hemi” or “unlinked” type implant/humero-radial implant) and the items specified in the glossary. The tolerance and methods of dimensional measurement shall conform to industry practice and, whenever possible, on an international basis.

7.2 The end user shall be able to determine the minimum ulnar bearing thickness (UBT), radial bearing thickness (RBT)(RBT), and/or humeral bearing thickness (HBT) of the UHMWPE components in the main articulating area(s) in accordance with Fig. 1 or Fig. 2. This may be achieved by directly specifying the dimensions in the packaging material or by providing a means to calculate the dimensions (see X2.9).

8. Finishing and Marking

8.1 Metallic components conforming to this specification shall be finished and marked in accordance with Practice F86, where applicable.

8.2 *Metallic Bearing Surface*—The main bearing surfaces shall have a surface finish no rougher than 0.2 μm roughness average,

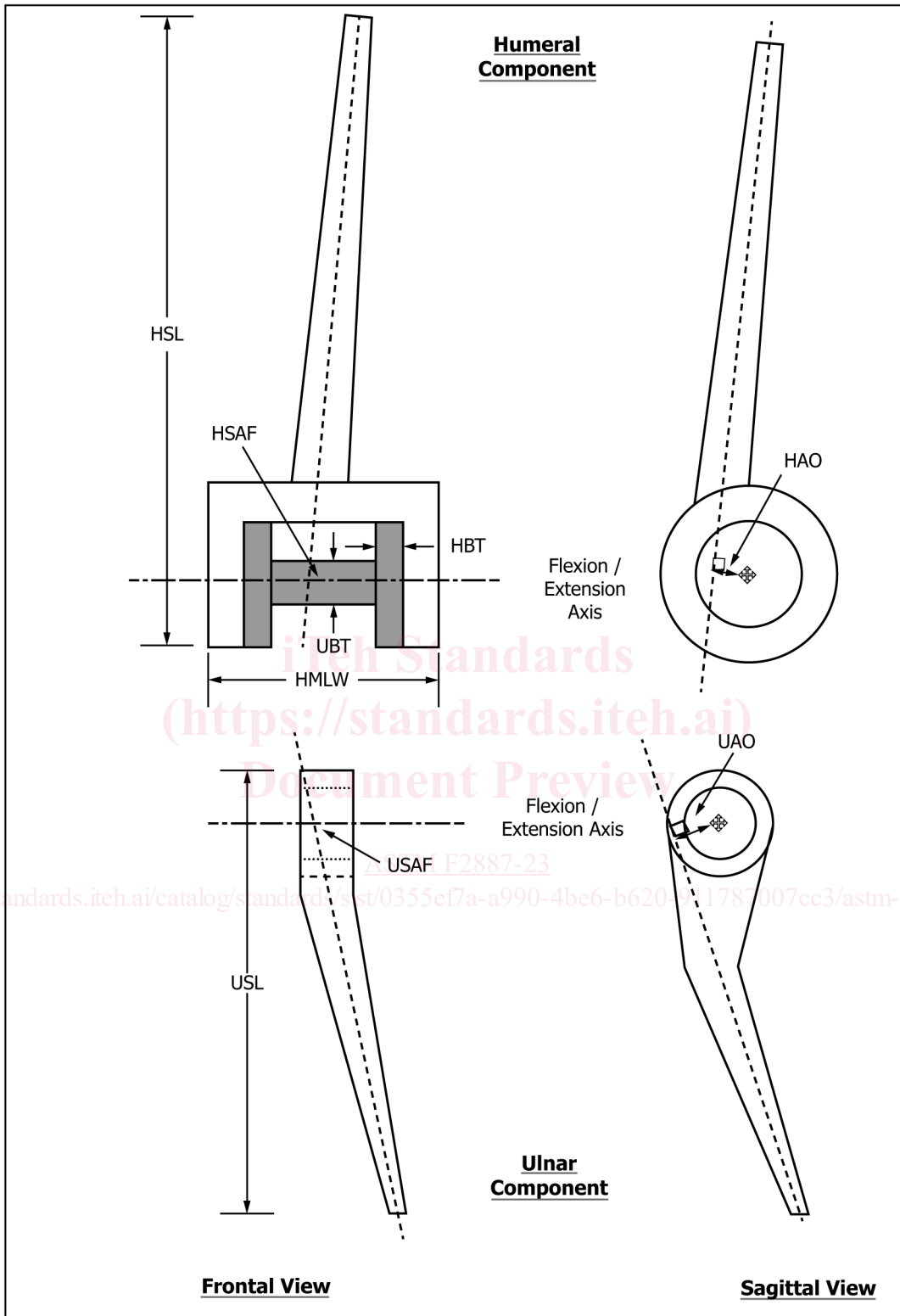

FIG. 1 General Depiction of Important Attributes of a Constrained (“linked, semi-constrained”) Fixed Bearing Total Elbow Replacement Components

Ra, when measured in accordance with the principles given in ANSI/ASME B46.1-1995. The following details should be documented: stylus tip radius, cutoff length of measuring instrument (0.25 mm recommended), and the position of measurement on the specimen. When inspected visually, the component shall be free from embedded particles, defects with raised edges, scratches, and score marks.