



Designation: **D6496/D6496M—20 D6496/D6496M – 23**

Standard Test Method for Determining Average Bonding Peel Strength Between Top and Bottom Layers of Needle-Punched Geosynthetic Clay Liners¹

This standard is issued under the fixed designation D6496/D6496M; the number immediately following the designation indicates the year of original adoption or, in the case of revision, the year of last revision. A number in parentheses indicates the year of last reappraisal. A superscript epsilon (ϵ) indicates an editorial change since the last revision or reappraisal.

1. Scope

1.1 This test method covers the laboratory determination of the average bonding strength between the top and bottom layers of a sample of a geosynthetic clay liner (GCL).

1.2 The values stated in either SI units or inch-pound units are to be regarded separately as standard. The values stated in each system may not be exact equivalents; therefore, each system shall be used independently of the other. Combining values from the two systems may result in nonconformance with the standard.

1.3 *This standard does not purport to address all of the safety concerns, if any, associated with its use. It is the responsibility of the user of this standard to establish appropriate safety, health, and environmental practices and determine the applicability of regulatory limitations prior to use.*

1.4 *This international standard was developed in accordance with internationally recognized principles on standardization established in the Decision on Principles for the Development of International Standards, Guides and Recommendations issued by the World Trade Organization Technical Barriers to Trade (TBT) Committee.*

2. Referenced Documents

2.1 ASTM Standards:²

[D76/D76M Specification for Tensile Testing Machines for Textiles](#)

[D123 Terminology Relating to Textiles](#)

[D4439 Terminology for Geosynthetics](#)

[D5889/D5889M Practice for Quality Control of Geosynthetic Clay Liners](#)

[D6072/D6072M Practice for Obtaining Samples of Geosynthetic Clay Liners](#)

3. Terminology

3.1 Definitions:

3.1.1 *geosynthetic clay liner, n*—a manufactured hydraulic barrier consisting of clay bonded to a layer or layers of geosynthetic material(s). **D4439**

¹ This test method is under the jurisdiction of ASTM Committee [D35](#) on Geosynthetics and is the direct responsibility of Subcommittee [D35.04](#) on Geosynthetic Clay Liners.

Current edition approved ~~May 1, 2020~~ March 1, 2023. Published ~~May 2020~~ March 2023. Originally approved in 1999. Last previous edition approved in ~~2019~~ 2020 as ~~D6496/D6496M—19~~ D6496/D6496M – 20. DOI: ~~10.1520/D6496_D6496M-20~~ 10.1520/D6496_D6496M-23.

² For referenced ASTM standards, visit the ASTM website, www.astm.org, or contact ASTM Customer Service at service@astm.org. For *Annual Book of ASTM Standards* volume information, refer to the standard's Document Summary page on the ASTM website.



3.2 For terminology of other terms used in this test method, refer to Terminologies [D123](#) and [D4439](#).

4. Summary of Test Method

4.1 The top and bottom layers of a geosynthetic clay liner are gripped individually in tensile grips and pulled at a constant rate of extension by a tensile testing machine until the top and bottom layers of the specimen separate. The average bonding peel strength of the test specimen can be calculated from machine scales, dials, recording charts, or an interface computer.

5. Significance and Use

5.1 The bonding strength test for the top and bottom layers of the geosynthetic clay liner is intended to be an index test. It is anticipated that the results of the test will be used to evaluate the quality of the bonding process.

6. Atmospheric Conditions

6.1 *Atmospheric Conditions:*

6.1.1 The atmospheric conditions of the laboratory determining average bonding peel strength between top and bottom layers of needle-punched geosynthetic clay liners shall be: relative humidity between 50 to 70 % and a temperature of 21 ± 2 °C [70 ± 4 °F].

7. Apparatus

7.1 *Tensile Testing Machine*—A constant rate of extension (CRE) type of testing machine described in Specification [D76/D76M](#) shall be used with a minimum precision measuring capability of 0.1 N/m [5.71×10^{-4} lbf/in.].

7.1.1 *Fixed Member*—A fixed or essentially stationary member carrying one clamp.

7.1.2 *Movable Member*—A movable member carrying a second clamp.

7.2 *Clamps*—The clamps shall be a minimum 25 by 100 mm [1 by 4 in.] and with appropriate clamping power to prevent slipping or crushing (damage). Clamps for holding the test specimen between the fixed member and the movable member of the test apparatus can be either a fixed or self-aligning type.

7.2.1 Fixed clamps are rigidly attached to the fixed and movable members of the test apparatus. Extreme care should be taken when this type of clamp is used to ensure that the test specimen is inserted and clamped so that the long axis of the test specimen coincides with the direction of pull through the centerline of the clamp assembly.

7.2.2 Self-aligning clamps are attached to the fixed and movable members of the test apparatus. This type of clamp assembly is such that they will move freely into alignment as soon as any load is applied as long as the long axis of the test specimen will coincide with the direction of the applied pull through the centerline of the clamp assembly. The specimens should be aligned as perfectly as possible with the direction of pull so that no rotary motion will occur in the clamps thereby inducing slippage; there is a limit to the amount of misalignment self-aligning clamps will accommodate.

7.3 *Die or Template*, 100 by 200 mm (± 1 mm) [4 by 8 in.].

7.4 *Miscellaneous*—Knives, razor, and the like, as required.

8. Sampling, Test Specimens, and Test Units

8.1 *Lot Sample*—For the lot sample, take rolls of GCLs as directed in an applicable material specification, Practice [D5889/D5889M](#), or as agreed upon between the purchaser and the supplier.

8.2 *Laboratory Sample*—For the laboratory sample, sample shall be taken in accordance with Practice [D6072/D6072M](#). The sample received at the testing laboratory should be in satisfactory condition and representative of the product manufactured or delivered to a site, or both.

8.3 *Test Specimens*—A minimum of five test specimens shall be taken in the machine direction from each swatch in the laboratory sample. Take specimens from the laboratory sample, with those for the measurement of the machine direction tensile properties from different positions across the GCL width. No specimens shall be taken within 10 cm [4 in.] of the selvage or edge of the GCL.

8.4 The size of the die or template for cutting specimens is 100 by 200 mm (minimum) [4 by 8 in.].

8.5 The loss of clay during the specimen cutting process should have no bearing on the results of the test.

9. Conditioning

9.1 The test specimen shall be tested as received.

10. Procedure

10.1 *Obtain Specimens*—Using the die, or template and razor, and other necessary apparatus, carefully cut from the laboratory sample five test specimens. The five specimens should be randomly selected from locations on the sample, but should be distributed across the sample. All specimens should be cut parallel to the machine direction. Using a knife or razor, separate the top and bottom layer of the GCL for the first 50 ± 3 mm [2 ± 0.1 in.].

10.2 *Machine Setup Conditions*—Adjust the distance between the clamps at the start of the test to 50 ± 3 mm [2 ± 0.1 in.]. Set the CRE at 300 mm/min [12 in./min].

10.3 *Insertion of Specimen in Clamps*—Mount the specimen centrally in the clamps. The specimen must be visually observed above the clamp. The specimen length in the machine direction must be parallel to the direction of application of force.

10.4 *Measurement of Bonding Peel Strength*—Start the tensile testing machine. This is considered the start of the peel test and represents zero grip separation. Take readings of force and time starting from 50 mm [2 in.] of grip separation until 250 mm [10 in.] of grip separation. The average recorded peeling force of the GCL over 200 mm [8 in.] of grip separation is required and will signify a complete test of the specimen. (See Fig. 1.)

ASTM D6496/D6496M-23

<https://standards.iteh.ai/catalog/standards/sist/8aceca14-1770-4373-bbb9-255cb7a94326/astm-d6496-d6496m-23>

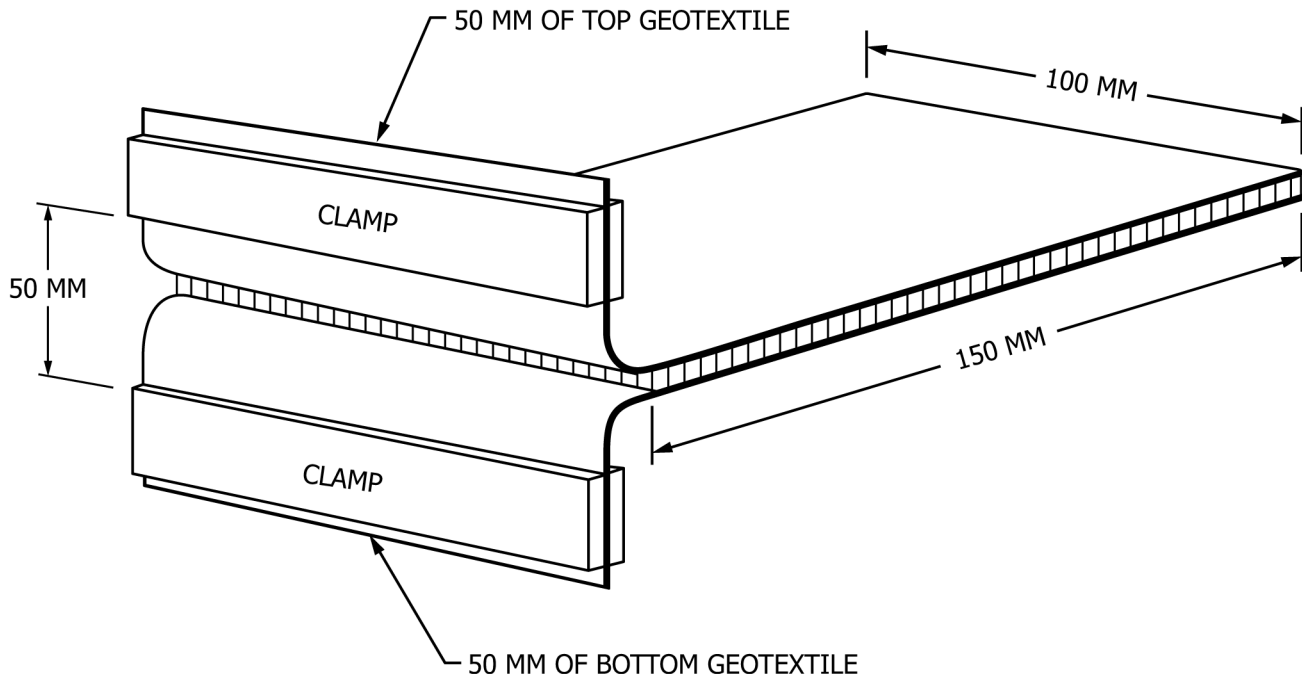

FIG. 1 Measurement of Bonding Peel Strength