



Designation: ~~D2639/D2639M—22~~ D2639/D2639M – 23

Standard Test Method for Plastic Properties of Coal by the Constant-Torque Gieseler Plastometer¹

This standard is issued under the fixed designation D2639/D2639M; the number immediately following the designation indicates the year of original adoption or, in the case of revision, the year of last revision. A number in parentheses indicates the year of last reapproval. A superscript epsilon (ϵ) indicates an editorial change since the last revision or reapproval.

1. Scope

1.1 This test method covers a relative measure of the plastic behavior of coal when heated under prescribed conditions. This test method may be used to obtain semiquantitative values of the plastic properties of coals and blends used in carbonization and in other situations where determination of plastic behavior of coals is of practical importance.

1.2 *Units*—The values stated in either SI units or inch-pound units are to be regarded separately as standard. The values stated in each system are not necessarily exact equivalents; therefore, to ensure conformance with the standard, each system shall be used independently of the other, and values from the two systems shall not be combined.

1.3 In this test method, the term “mass” applies to measurements expressed with both SI units (for example, kg) and inch-pound units (for example, lb).

1.4 *This standard does not purport to address all of the safety concerns, if any, associated with its use. It is the responsibility of the user of this standard to establish appropriate safety, health, and environmental practices and determine the applicability of regulatory limitations prior to use.*

1.5 *This international standard was developed in accordance with internationally recognized principles on standardization established in the Decision on Principles for the Development of International Standards, Guides and Recommendations issued by the World Trade Organization Technical Barriers to Trade (TBT) Committee.*

2. Referenced Documents

2.1 ASTM Standards:²

[D2013/D2013M Practice for Preparing Coal Samples for Analysis](#)

[D2234/D2234M Practice for Collection of a Gross Sample of Coal](#)

3. Terminology

3.1 Definitions:

3.1.1 *breaking, v* —free spinning behavior of coal, either by an abrupt change to rotating at maximum motor speed or by abrupt changes in rotation, which occurs as a result of a molten ball of coal forming around the base of the stirrer, and which makes reporting of the true maximum fluidity of the coal difficult.

¹ This test method is under the jurisdiction of ASTM Committee D05 on Coal and Coke and is the direct responsibility of Subcommittee D05.15 on Metallurgical Properties of Coal and Coke.

Current edition approved Dec. 1, 2022/March 1, 2023. Published December 2022/March 2023. Originally approved in 1967. Last previous edition approved in 2021/2022 as ~~D2639/D2639M—21a~~ D2639/D2639M – 22. DOI: ~~10.1520/D2639-D2639M-22~~ 10.1520/D2639_D2639M-23.

² For referenced ASTM standards, visit the ASTM website, www.astm.org, or contact ASTM Customer Service at service@astm.org. For *Annual Book of ASTM Standards* volume information, refer to the standard's Document Summary page on the ASTM website.

3.1.2 *dial division per minute, (DDPM), n*—as used in this test method, the stirrer rotation rate as measured by the accumulated rotations (full or partial) of the stirrer recorded over sequential 1 min periods based upon 100 dial divisions for each complete 360° rotation of the stirrer.

3.1.2.1 *Discussion*—

Historically stirrer rotations were recorded on manual plastometers by a simple timed observation of the total rotations at the completion of each sequential whole minute interval as the furnace was ramped over the required temperature range. Modern instruments have the ability to record the accumulated stirrer rotations at any given point during the test and as such can present the DDPM over any discrete 60 s interval. For the purposes of this empirical standard and in order to ensure consistency between instrumentation, the recorded DDPM shall be taken at the end of each sequential minute interval commencing at the start of the test and ending with the recorded solidification temperature. That is to say, upon regaining the initial temperature of 300 °C, total accumulated stirrer rotations shall be recorded at times 00:01:00, 00:02:00, 00:03:00, 00:04:00, etc. until the solidification temperature is reached.

3.1.3 *initial softening temperature, n*—as used in this test method, the temperature at which the DDPM (see 3.1.2) first reaches a reading of equal to or greater than 1.0.

3.1.4 *jamming, v*—swelling up of coal into the retort tube during the test, which may produce lower fluidity results than expected and can only be noted after visual inspection of the disassembled crucible and retort at the conclusion of the test.

3.1.5 *maximum fluidity, n*—as used in this test method, the measured maximum stirrer rotation rate, in dial divisions per minute.

3.1.6 *maximum fluidity temperature, n*—as used in this test method, the temperature at which stirrer rotation rate reaches a maximum value.

3.1.7 *plastic range, n*—difference between the solidification temperature and the initial softening temperatures.

3.1.8 *solidification temperature, n*—as used in this test method, the temperature at which the DDPM (see 3.1.2) indicates the last stirrer rotation.

3.1.8.1 *Discussion*—

Modern instruments have the capability to measure fractional rotations of the stirrer. For the purposes of this test method, the solidification temperature shall be recorded as the temperature corresponding to the DDPM (see 3.1.2) that exhibits the last non-zero reading. Solidification temperature can also be defined as the temperature of the recorded DDPM immediately preceding the first DDPM of zero.

4. Summary of Test Method

4.1 The plastometer measures the plastic properties of coals by the use of a constantly applied torque on a stirrer placed in a crucible into which the coal is charged. The crucible is immersed in a bath and the temperature increased uniformly. The rates of movement of the stirrer are recorded in relation to increase in temperature.

5. Significance and Use

5.1 Reliable values of the plastic properties of coals are used to predict or explain the behavior of a coal or blends during carbonization or in other processes such as gasification, liquefaction, and combustion.

6. Apparatus

6.1 *Gieseler Plastometer*—The apparatus shall consist of the following:

6.1.1 *Retort*—A steel retort consisting of four parts as shown in Fig. 1.

6.1.2 *Retort Crucible*, cylindrical, 21.4 mm ± 0.08 mm [0.844 in. ± 0.003 in.] in inside diameter and 35.0 mm [1.38 in.] in depth, with exterior threads for joining the crucible to the crucible cover. The crucible shall have a 2.38 mm ± 0.02 mm [0.094 in. ± 0.001 in.] diameter notch in the center of its inside base to serve as a seat for the stirrer.

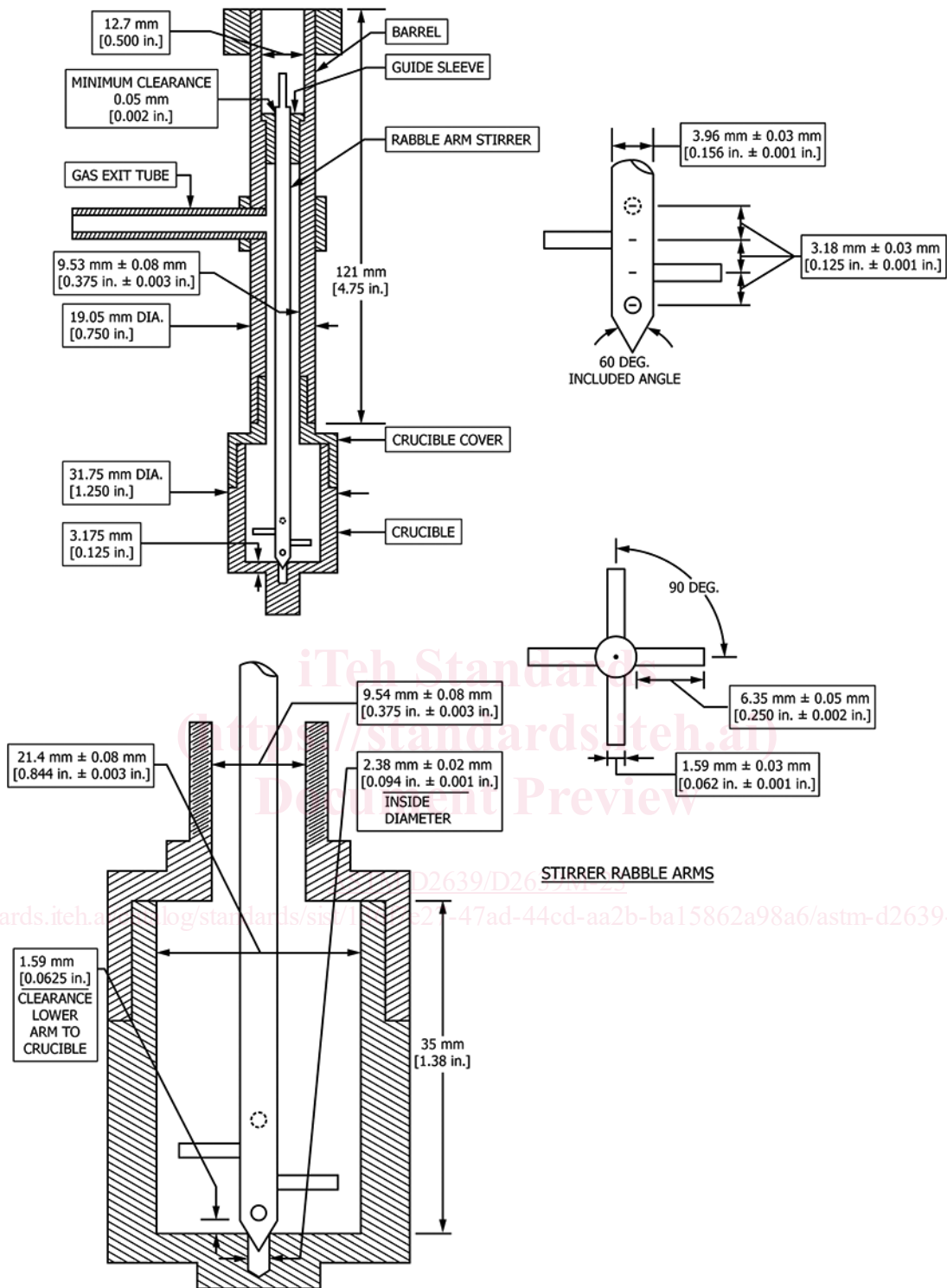

FIG. 1 Retort Assembly

6.1.3 *Retort Crucible Cover*, with interior threads for joining the crucible cover to the crucible and exterior threads for joining the crucible cover to the barrel. The inside diameter of the hole which accommodates the stirrer is 9.53 mm ± 0.08 mm [0.375 in. ± 0.003 in.].

6.1.4 *Barrel*, 121 mm [4.75 in.] long and having an inside diameter of 9.53 mm ± 0.08 mm [0.375 in. ± 0.003 in.]. The top end

of the barrel shall be 12.7 mm [0.500 in.] in inside diameter to a depth sufficient to allow clearance for the axle of the plastometer head when the apparatus is assembled. A hole, fitted with a tube, shall be provided at the midpoint of the barrel so as to afford exit for the volatile products during a test.

6.1.5 *Steel Stirrer*, provided with a straight shaft $3.96 \text{ mm} \pm 0.03 \text{ mm}$ [0.156 in. \pm 0.001 in.] in diameter and equipped with four rabble arms. The lower end of the stirrer shall have a 60° included angle. The rabble arms on the stirrer shall be $1.59 \text{ mm} \pm 0.03 \text{ mm}$ [0.0625 in. \pm 0.001 in.] in diameter, $6.35 \text{ mm} \pm 0.05 \text{ mm}$ [0.250 in. \pm 0.002 in.] in length, and shall be placed perpendicular to the shaft at 90° intervals around the shaft and $3.18 \text{ mm} \pm 0.03 \text{ mm}$ [0.125 in. \pm 0.001 in.] apart center to center along the shaft. The middle two rabble arms shall be set at 180° to each other, and likewise, the remaining two arms 180° to each other. The lowest rabble arm shall be set in the shaft to give 1.59 mm [0.0625 in.] clearance between it and the bottom of the crucible when the stirrer is in place. The upper end of the stirrer shall be cut to fit into the slot on the lower end of the axle in the plastometer head.

6.1.6 *Guide Sleeve*, provided near the upper end of the stirrer to guide the latter within the barrel, with a clearance of at least 0.05 mm [0.002 in.].

6.2 *Plastometer Head*—The plastometer head shall consist of a fixed-speed motor connected directly to a hysteresis brake which is capable of adjustment from 29 g·cm to 290 g·cm [11.4 g·in. to 114 g·in.] torque. Each complete revolution, or 100 dial division, shall be recorded on a magnetic counter actuated by an electric eye or other suitable method. The torque shall be checked using a drive pulley, transfer pulley, monofilament line, and weights/masses as shown in Fig. 2. Adjust the hysteresis

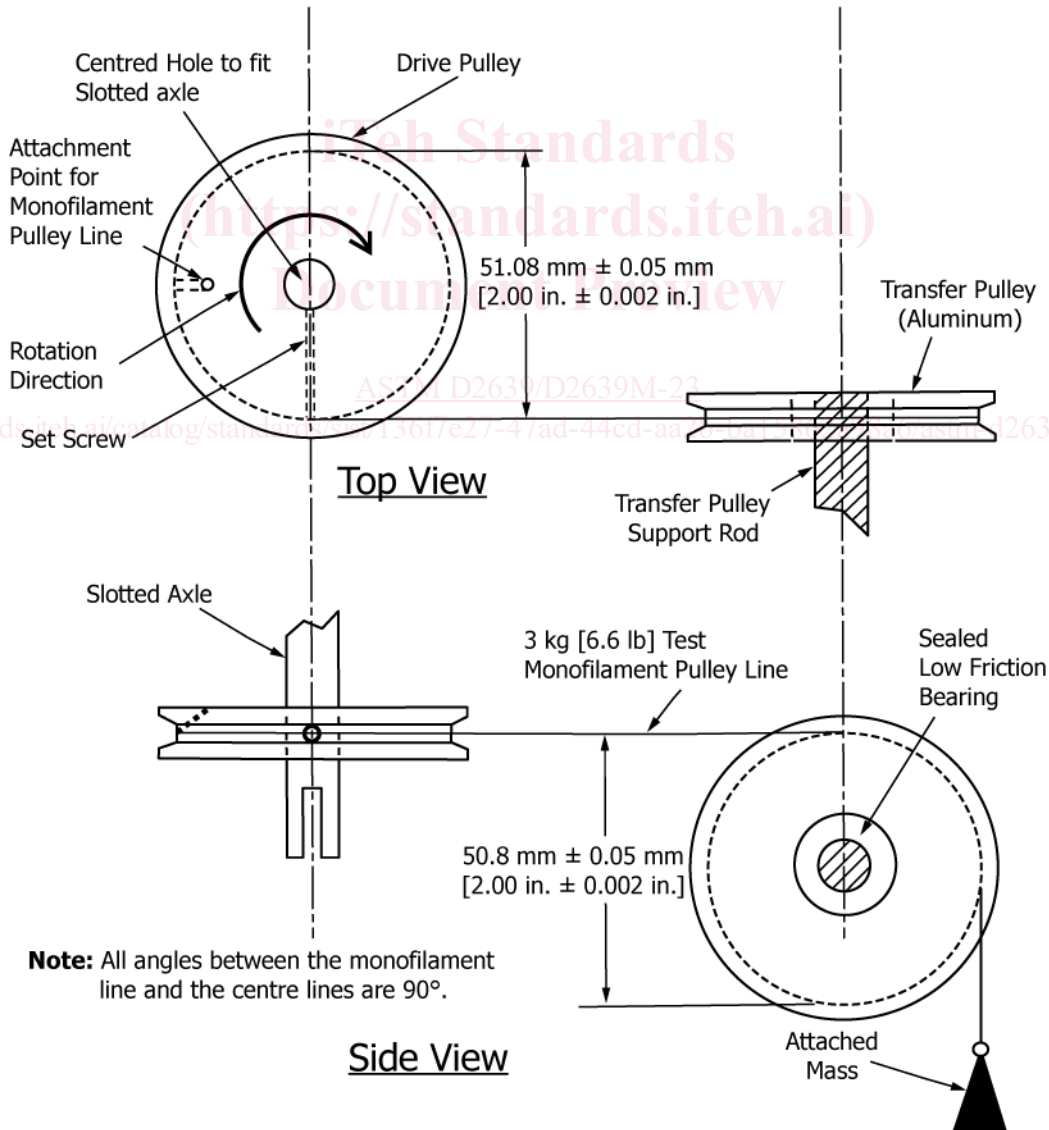

FIG. 2 Pulley Arrangement to Calibrate Torque

brake torque to lift a $38.00\text{ g} \pm 0.1\text{ g}$ [$38.0\text{ g} \pm 0.1\text{ g}$] [$0.0836\text{ lb} \pm 0.00022\text{ lb}$] ~~weight~~ 0.0002 lb mass over one full rotation of the slotted axle and not lift a $42.00\text{ g} \pm 0.1\text{ g}$ [$0.924\text{ lb} \pm 0.00022\text{ lb}$] ~~weight~~ $42.0\text{ g} \pm 0.01\text{ g}$ [$0.0924\text{ lb} \pm 0.0002\text{ lb}$] mass over one full rotation of the slotted axle. The lifted ~~weights~~ masses include the variable weight of the monofilament line between the transfer pulley and the attached ~~weight~~ mass. All instruments should be checked in this manner at least once each week.

6.3 *Furnace*—An electrically heated furnace with suitable manual, or automatic, controls shall be provided so that a heating rate of $3.0\text{ }^\circ\text{C}/\text{min} \pm 0.1\text{ }^\circ\text{C}/\text{min}$ [$5.4\text{ }^\circ\text{F}/\text{min} \pm 0.18\text{ }^\circ\text{F}/\text{min}$], on an over-all basis, with not more than $3.0\text{ }^\circ\text{C} \pm 1.0\text{ }^\circ\text{C}$ [$5.4\text{ }^\circ\text{F} \pm 1.8\text{ }^\circ\text{F}$] for any given minute can be maintained over a temperature range from $300\text{ }^\circ\text{C}$ to $550\text{ }^\circ\text{C}$ [$572\text{ }^\circ\text{F}$ to $1022\text{ }^\circ\text{F}$]. This temperature circuit should be checked and standardized periodically. The furnace shall contain a molten solder bath of approximately 50 % lead and 50 % tin composition. Temperature in the bath shall be measured with a suitable thermocouple contained in an outer protection tube immersed in the bath so that the protection tube touches the outside wall of the crucible, and the measuring junction of the thermocouple is at the same height as the center of the coal charge. A stirrer shall be used to agitate the solder. A suitable furnace is illustrated in Fig. 3.

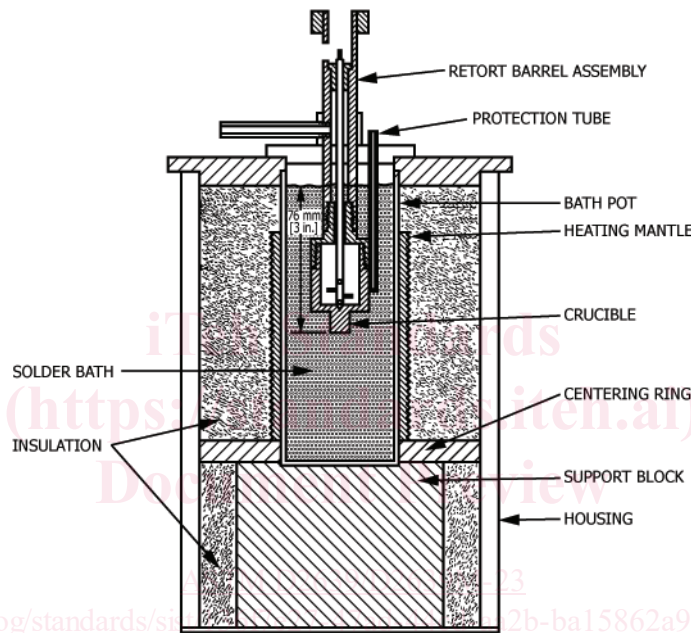

FIG. 3 Furnace Assembly

6.4 *Loading Device*—The loading device shall be provided so that the coal may be packed uniformly in the crucible under a total packing load mass of 10 kg [22 lb] and designed in such a manner that, after compression, the crucible and its contents can easily be removed from the device without disturbing the contents. An example of the static-weight-static mass device is shown in Fig. 4. The use of a static weight mass of 9 kg [20 lb] together with a drop-weight-drop mass of 1 kg [2 lb] dropped twelve times from a height of 110 mm [4.5 in.] is permissible as an alternative method of packing. An example of the drop-weight-drop mass arrangement is shown in Fig. 5. For coals that are difficult to pack, it is permissible to add one to three drops of water on the shaft of the stirrer near the surface of the coal before the weight mass is added.

7. Sample

7.1 Collect a representative gross sample of coal in accordance with Practice D2234/D2234M and prepare in accordance with Practice D2013/D2013M. The 2.36 mm [No. 8] sieve sample from Table 1 in Practice D2013/D2013M shall constitute the laboratory sample.

8. Preparation of Sample

8.1 Air dry the sample prior to preparation. Spread the sample on tared pans, weigh, determine the mass, and air dry it the sample at room temperature or at slightly elevated temperatures not exceeding $15\text{ }^\circ\text{C}$ [$27\text{ }^\circ\text{F}$] above room temperature, until the moisture loss is less than 0.1 %/h. Drying should shall not be continued beyond this point so that the plastic properties of the coal are not altered by oxidation. After air drying, reduce the sample by riffing to no less than 0.5 kg [1 lb]. Stage crush this 0.5 kg [1 lb]