



Designation: C945 – 05 (Reapproved 2023)

# Standard Practice for Design Considerations and Spray Application of a Rigid Cellular Polyurethane Insulation System on Outdoor Service Vessels<sup>1</sup>

This standard is issued under the fixed designation C945; the number immediately following the designation indicates the year of original adoption or, in the case of revision, the year of last revision. A number in parentheses indicates the year of last reapproval. A superscript epsilon ( $\epsilon$ ) indicates an editorial change since the last revision or reapproval.

## 1. Scope

1.1 This practice concerns itself with the substrate preparation and priming, the selection of the rigid cellular polyurethane system, and the protective insulation coatings for outdoor service equipment.

NOTE 1—For the purpose of this practice, polyurethane is defined to mean either polyurethane or polyisocyanurate and is hereafter referred to as “PUR/PIR.”

1.2 The values given in inch-pound are to be regarded as the standard. The values given in parentheses are for information only.

1.3 *This standard may involve hazardous materials, operations, and equipment. This standard does not purport to address all of the safety concerns, if any, associated with its use. It is the responsibility of the user of this standard to establish appropriate safety, health, and environmental practices and determine the applicability of regulatory limitations prior to use.*

1.4 *This international standard was developed in accordance with internationally recognized principles on standardization established in the Decision on Principles for the Development of International Standards, Guides and Recommendations issued by the World Trade Organization Technical Barriers to Trade (TBT) Committee.*

## 2. Referenced Documents

2.1 *ASTM Standards:*<sup>2</sup>

[C168 Terminology Relating to Thermal Insulation](#)

[D883 Terminology Relating to Plastics](#)

[D1600 Terminology for Abbreviated Terms Relating to Plastics](#)

[D2200 Practice for Use of Pictorial Surface Preparation Standards and Guides for Painting Steel Surfaces](#)

2.2 *American National Standards:*

[Z87.1 Practice for Occupational and Educational Eye and Face Protection](#)<sup>3</sup>

2.3 *Clemtex Limited Standard:*  
“[Anchor Pattern Standard](#)”<sup>4</sup>

2.4 *National Association of Corrosion Engineers Standard:*  
[TM-01-70 Visual Surface Preparation Panels](#)<sup>5</sup>

2.5 *Other Documents:*

[Safety Precautions in Handling and Spraying of PUR/PIR Systems](#)<sup>6,7</sup>

## 3. Terminology

3.1 *Definitions*—Definitions included in Terminology [C168](#), Definitions [D883](#), and Abbreviations [D1600](#) apply to the terms used in this standard.

3.2 *Definitions of Terms Specific to This Standard:*

3.2.1 *blasting*—the process of cleaning surfaces by use of abrasive particles propelled at high velocity upon the surface to be cleaned.

3.2.2 *coatings/coverings*—ultraviolet ray-absorbing and water-shedding protective materials applied over the urethane foam.

3.2.3 *density:*

3.2.3.1 *in-place density*—the weight per unit volume of the cross section of foam from substrate to exposed surface, including all skins (or surfaces).

3.2.3.2 *core density*—the weight per unit volume of a single layer of foam excluding top and bottom skins or (if present) interlayer skins.

<sup>1</sup> This practice is under the jurisdiction of ASTM Committee [C16](#) on Thermal Insulation and is the direct responsibility of Subcommittee [C16.40](#) on Insulation Systems.

Current edition approved March 1, 2023. Published March 2023. Originally approved in 1981. Last previous edition approved in 2017 as C945 – 05 (2017). DOI: 10.1520/C0945-05R23.

<sup>2</sup> For referenced ASTM standards, visit the ASTM website, [www.astm.org](http://www.astm.org), or contact ASTM Customer Service at [service@astm.org](mailto:service@astm.org). For *Annual Book of ASTM Standards* volume information, refer to the standard’s Document Summary page on the ASTM website.

<sup>3</sup> Available from American National Standards Institute (ANSI), 25 W. 43rd St., 4th Floor, New York, NY 10036, <http://www.ansi.org>.

<sup>4</sup> Available from Clemtex Ltd., P.O. Box 15214, Houston, TX 77020.

<sup>5</sup> Available from NACE International (NACE), 1440 South Creek Dr., Houston, TX 77084-4906, <http://www.nace.org>.

<sup>6</sup> Spray Polyurethane Foam Alliance (SPFA), 4400 Fair Lakes Ct, Suite 105, Fairfax, VA, <http://sprayfoam.org>

<sup>7</sup> Alliance for the Polyurethane Industry (API), 1300 Wilson Blvd Suite 800, Arlington, VA 22209, <http://polyurethanes.org>

3.2.4 *foam system*—appropriate formulations of two liquid components, polyisocyanate, or A side, and polyol, or B side, for intended applications.

3.2.5 *ignition barrier*—cement plaster or equivalent coating/covering providing a resistance to ignition of the foam insulation acceptable to the concerned building or fire department(s), or both. (Designated UL test is optional.)

#### 4. Significance and Use

4.1 This practice facilitates the selection and application of an insulation system for use at service temperatures between  $-30$  and  $+107^{\circ}\text{C}$  ( $-22$  and  $+225^{\circ}\text{F}$ ). Although the successful installation of spray-applied PUR/PIR is influenced by many factors, this practice treats those four areas found to be of major importance:

- (1) Substrate preparation,
- (2) Substrate priming,
- (3) Insulation application, and
- (4) Protective coatings.

4.2 Abrasive blasting, primer application, spray application of the insulation, and protective coating application each contribute their unique health and safety hazards to the job site and will be dealt with in more detail under their respective headings.

#### 5. Substrate Preparation

5.1 Proper substrate preparation is mandatory to obtain a successful foam application. These preparation methods must remove any contaminants that will interfere with development of the maximum adhesion of the urethane foam. The method(s) chosen are dependent upon the contaminants present on the surface and the end-use design service temperature.

5.1.1 *Previously Coated Iron and Steel Surfaces*—The adhesion of spray-applied urethane to previously coated surfaces is directly influenced by the age, type, and condition of the surface. For this reason any coating that exhibits chalking, peeling, or other evidence of failure or damage must be removed and an appropriate primer applied. **Abrasive blasting is recommended.** If blasting is to be accomplished, all items listed under Section 6 should be followed. In all cases, the coated substrate must be cleaned and free of rust, grease, oil, dirt, dust, moisture, etc., immediately prior to foam spraying by one or more of the following methods: (a) wash with water and allow to dry, (b) brush, (c) broom, or (d) air blast.

5.1.2 *New Iron or Steel Surfaces*—Field blasting and priming is recommended. All blasting is to be accomplished in accordance with items listed in Section 6. Shop preparation is also acceptable with proper field surface preparation of the weld joints and all damaged areas. In all cases, the substrate to be sprayed with foam shall be free of rust, grease, oil, loose particles, and mill scale, moisture, dirt, etc. After priming is complete, all areas that are specified to be insulated shall be washed with water and allowed to dry, brushed, broomed, or air-blasted prior to applying the insulation.

NOTE 2—Caution: Be sure the primer is useable at the design temperature and acceptable under the foam insulation.

5.1.3 *Galvanized Metal Surfaces*—Clean with an acceptable solvent, wash with water to remove deposits, spray with an acceptable wash primer, and then coat all areas with an acceptable primer or coating.

NOTE 3—This procedure is not always required depending on the age of the metal, exposure, and use.

5.1.4 *Aluminum Surfaces*—Degrease with appropriate solvents. Coat the clean, dry surface with a recommended primer or coating.

5.1.5 *Stainless Steel Surfaces*—Degrease with appropriate solvents. Coat the clean, dry surface with a recommended primer or coating. (Chloride-free materials are recommended on surfaces operating above  $140^{\circ}\text{F}$  ( $60^{\circ}\text{C}$ )).

#### 6. Recommended Blasting Procedures

6.1 All surfaces to be primed or coated shall be prepared to the degree of cleanliness and surface profile as recommended by the primer supplier. Pictorial D2200 shall be used as the standard. Blast-cleaned surface acceptance will be by one or more of the following visual comparison methods: “Anchor Pattern Standards” NACE Visual Surface Preparation Panels (Standard TM-01-70), and Pictorial D2200.

6.2 All welding, burning, etc., shall be completed prior to the blasting operation.

6.3 Remove any grease or oil with a petroleum solvent or water-detergent solution. All flux, spatter, slag, or other laminations left from welding must be chipped or ground off. Rough welds and other sharp projections should be ground smooth by the fabricator prior to the blasting operation.

6.4 Sandblast sand shall be sharp, graded flint or silica sand (16 to 30 mesh). Where inorganic zinc coatings are applied, the surface preparation shall be abrasive blasted using 16 to 30-mesh sand, G40 to 50 grit, or an equivalent abrasive that will provide a similar surface profile. All abrasives shall be free of all dust, dirt, and other foreign matter. They shall be kept dry and free of oil at all times.

#### MANDATORY HEALTH AND SAFETY PRECAUTIONS FOR BLASTING OPERATIONS

6.4.1 Effective oil and water traps shall be used to ensure clean, dry air supply to the abrasive pot. Water shall be continuously bled from the moisture trap.

6.4.2 A “dead-man” valve shall be used on all blast nozzles.

6.4.3 All blast hoses shall have an antistatic lining.

6.4.4 All blast nozzles shall be properly grounded.

6.4.5 Nozzle blast operators exposed to blasting dust shall wear a U.S. Bureau of Mines-approved helmet connected to a clean, breathable compressed air source.

6.4.6 All others exposed to blasting dust shall wear a U.S. Bureau of Mines-approved filter-type respirator. Adequate personnel protection from flying particles shall be provided in any blasting operation.

6.4.7 If at any time the blasting equipment and material specifications are not being met, the owner may suspend the operation.

6.4.8 Blasted surfaces shall not be allowed to become wet or dulled by oxidation to a point where visible rusting has occurred.

6.4.9 All surfaces shall be primed during the same day that they are blasted.

6.4.10 Surface cleanliness and profile depth shall be suitable for the metal primer to be used. These conditions shall be monitored in accordance with the visual comparison methods specified herein.

6.4.11 Surfaces inspected and found to not meet the criteria outlined in 6.1 – 6.4 must be blasted again.

## 7. Selection of Metal Primer

7.1 The following items shall be considered when choosing a metal primer:

7.1.1 Surface preparation required,

7.1.2 Foam adhesion, substrate adhesion, and heat resistance at the maximum and minimum vessel operating temperatures, and

7.1.3 Corrosion resistance to spilled vessel contents.

7.2 Listed below are general application recommendations, which may vary depending on the type of primer selected:

7.2.1 The manufacturer's recommendations for thinning, mixing, handling, and applying his products shall be considered a part of this practice.

7.2.2 All bolts, welds, faying surfaces, sharp edges, and difficult access areas shall receive a primer spot-coat prior to primer spray application.

7.2.3 The primer shall be applied in a fashion to obtain complete coverage.

7.2.4 Primer shall not be applied during rain, snow, fog, mist, high relative humidity, or low metal temperatures. The relative humidity and dew point shall be determined at the job site using a surface thermometer and wet/dry bulb sling psychrometer.

7.2.4.1 Priming of the metal shall not be permitted when the temperature of the metal is at or below the dew point or above the dew point and falling with the temperature expected to reach the dew point before the application is complete. Priming shall be permitted when the temperature is above the dew point and rising or expected to remain above the dew point while application is taking place.

7.2.5 Primer shall be applied to a clean, dry substrate free of dirt, sand, and loose foreign matter.

7.2.6 The substrate shall be prepared in accordance with Section 5 prior to metal primer application. Any metal oxidizing or developing rust prior to primer application shall be returned to the specified degree of surface preparation.

7.2.7 After the primer has been applied and allowed to dry, inspect the primer for holidays and adequate dry film thickness. Where inadequate dry film thickness or holidays exist, additional material shall be applied or the surface reconditioned and the primer reapplied. Same as 7.2.6.

7.2.8 Primer spray application equipment shall be that recommended by the coating manufacturer. Compressed air sources shall have moisture traps. Before spray application begins, all hoses and guns shall be solvent-flushed and inspected to ensure that no moisture is present.

7.2.9 All flames, sparks, welding, and smoking shall be prohibited in the application area.

7.2.10 All affected items, in the surrounding area, shall be protected from overspray.

7.2.11 Spray guns must be held perpendicular to the surface being painted and adjusted so that dry overspray is minimized.

## 8. Selection of the Foam System

8.1 A wide range of foam systems is available in various densities, each exhibiting different temperature limitations, combustibility characteristics, etc. The use of these systems in combination with each other or with conventional insulation products offer a broad range of economical installations.

8.2 Published properties are usually determined on laboratory-produced samples. The thickness of foam sprayed, number of passes, temperature of the substrate, ambient temperatures, etc., have a pronounced effect on all properties.

8.3 Resistance to chemical attack from in-service exposure shall be considered in the selection of the proper foam system. The degree of possible damage to the foam system is determined by the amount of the chemical, its type, temperature, and duration of contact.

8.4 Listed below are several items that shall be considered in the selection of the foam system:

8.4.1 Insulation temperature limitation versus vessel operating design temperature,

8.4.2 Dimensional stability under simulated service conditions,

8.4.3 Combustibility characteristics,

8.4.4 Application conditions (substrate and ambient temperatures, etc.),

8.4.5 History of similar application or laboratory data relating to the application in question,

8.4.6 Compressive strength,

8.4.7 Adhesion to substrate, and

8.4.8 Thermal resistance.

### 8.5 Handling of Foam System Materials:

8.5.1 Materials shall be stored in accordance with the manufacturer's recommendations.

8.5.2 All materials associated with the foam system shall be delivered to the job site in unopened standard commercial containers bearing the manufacturer's original label with the following information:

8.5.2.1 Name of manufacturer,

8.5.2.2 Name of contents,

8.5.2.3 Net weight of contents,

8.5.2.4 Lot or batch number,

8.5.2.5 Recommended storage temperature range,

8.5.2.6 A "caution" label giving safety instructions for handling and storage temperature range,

8.5.2.7 Mixing instructions, and

8.5.2.8 Listing agency label, if applicable, plus Certificate of Conformance. The contractor shall keep a record of this information throughout the guarantee period.

8.5.3 Containers shall not be opened until ready for immediate use. Undue agitation of containers shall be avoided.

8.5.4 In the case of bulk shipments, the spray foam contractor may transfer each of the urethane components into appropriately sized clean dry containers or containers that have previously contained the same material. Care shall be taken to exclude moisture pick-up during transfer operations and each container shall be blanketed with an inert, dry atmosphere.

8.6 *Application of Spray Foam:*

8.6.1 Manufacturer’s application instructions shall be followed at all times. Only qualified applicators with prior experience spraying the specified foam system shall be used. Prior to application of the spray foam, the contractor shall apply a test area to one of the vessels to be insulated. This area shall be checked for:

- 8.6.1.1 General foam surface appearance,
- 8.6.1.2 Specified foam thickness,
- 8.6.1.3 Local surface roughness,
- 8.6.1.4 Foam quality—striations, voids, uniform cells, etc., and
- 8.6.1.5 Foam adhesion.

8.6.2 The accepted panel shall be left on the tank and shall be the standard for the complete tank insulation.

8.6.3 The foam shall be applied to roof and shell at substrate temperatures of 60 to 150°F (16 to 66°C) in minimum ½-in. (13-mm) thick passes to reach the desired thickness with a –0, +½-in. tolerance. (The substrate temperatures stated above will vary depending upon the foam system selected.) In areas where obstacles do not permit normal spray techniques and the application tolerances specified above cannot be met, the contractor may apply the specified minimum thickness of foam required by a method that he shall select. However, the completed application of foam shall be monolithic with adjacent areas of normal application. All foam applied over vessel roofs shall be applied in a manner to provide drainage and prevent free-standing water.

8.6.4 Extreme caution shall be taken to prevent spraying in the presence of water (rain, fog, condensation, etc.), as well as when wind velocities are greater than 15 mph (24 km/h). (Shielded scaffolds shall be used to allow spraying in high wind velocities with owner’s approval.)

8.6.5 The equipment shall be operated within the temperature parameters as specified by the foam manufacturer.

8.6.6 The applicator shall keep with him on the scaffolding or on the roof, or in both locations, sufficient buckets, plastic film, etc., to enable him to counteract a problem without depositing any foreign material on the substrate that would affect either initial adhesion to the substrate or interlaminar adhesion of the foam.

8.6.7 An appropriate insulating material (1 to 2 in. (25 to 51 mm) in thickness) shall be installed prior to foam application in an area approximately 2 by 2 ft (610 by 610 mm) on the tank surrounding all steam inlet or outlet lines, or any area where a temperature of 225°F (107°C) or above is possible (see Fig. 1).

NOTE 4—Figs. 1-8 are illustrative of accepted techniques for applying spray foam to commonly encountered equipment.

9. Coatings

9.1 When foam is exposed to the weather, used in areas where surface water will accumulate, or in a corrosive

atmosphere, a protective coating is necessary. As coating performance is proportional to the applied film thickness, minimal film thickness should be avoided.

9.2 *Selection*—For proper selection of the coating material, the following items shall be considered:

- 9.2.1 Environment in which to be used (high-traffic, hail, rain, chemical, etc.),
- 9.2.2 Resistance to spilled vessel contents,
- 9.2.3 Life expectancy,
- 9.2.4 Ease of maintenance,
- 9.2.5 History of similar applications or laboratory data relating to the application in question,
- 9.2.6 Combustibility characteristics,
- 9.2.7 Water vapor permeance,
- 9.2.8 Application conditions (temperature, etc.), and
- 9.2.9 Building code, insurance company, fire department requirements.

9.3 *Application:*

9.3.1 The coating shall be applied in accordance with manufacturer’s instructions and shall be applied the same day the foam insulation is installed, except in case of unusual circumstances, and with foam applicator’s approval. The coating shall not be applied until the foam has aged 1 h. Figs. 1-11 illustrate some application techniques.

9.3.2 The foam shall be dry, clean, free of dust, and foam overspray before application.

9.3.3 The proper thickness of an approved coating for the intended application shall be applied. The coating may be installed in one or more coats. If more than one coat is specified, contrasting colors shall be used with the final coat being the finished color. It is also good practice to install additional thickness (mils) around heavily worked areas, such as manways, vents, etc. Mechanical protection is also recommended.

9.3.4 The criss-cross, or cross-spray, technique shall be used without runs.

9.3.5 The first coat shall be stopped approximately 12 to 18 in. (300 to 450 mm) from the edge of the applied foam. Do not apply to bare steel surfaces that are to be insulated.

9.3.6 Around each protrusion on the roof area and in the area where the stairs adjoin the vessel (size of the area to be selected by owner), the coating shall be reinforced in one of the following manners:

9.3.6.1 Prior to the final coat, embed an open-weave reinforcing fabric into the wet first coat. Caution shall be taken to embed the reinforcing fabric totally within the coating.

9.3.6.2 Apply an extra 20 mils (0.51 mm) minimum of the selected coating in a one or more coat application.

9.3.7 After the coating application is complete, the insulation system shall be stenciled in a prominent place with minimum 4-in. (100-mm) lettering as follows:

**SOFT INSULATION  
DO NOT DAMAGE  
FOAM INSULATION  
DO NOT WELD OR BURN  
TANK NUMBER \_**

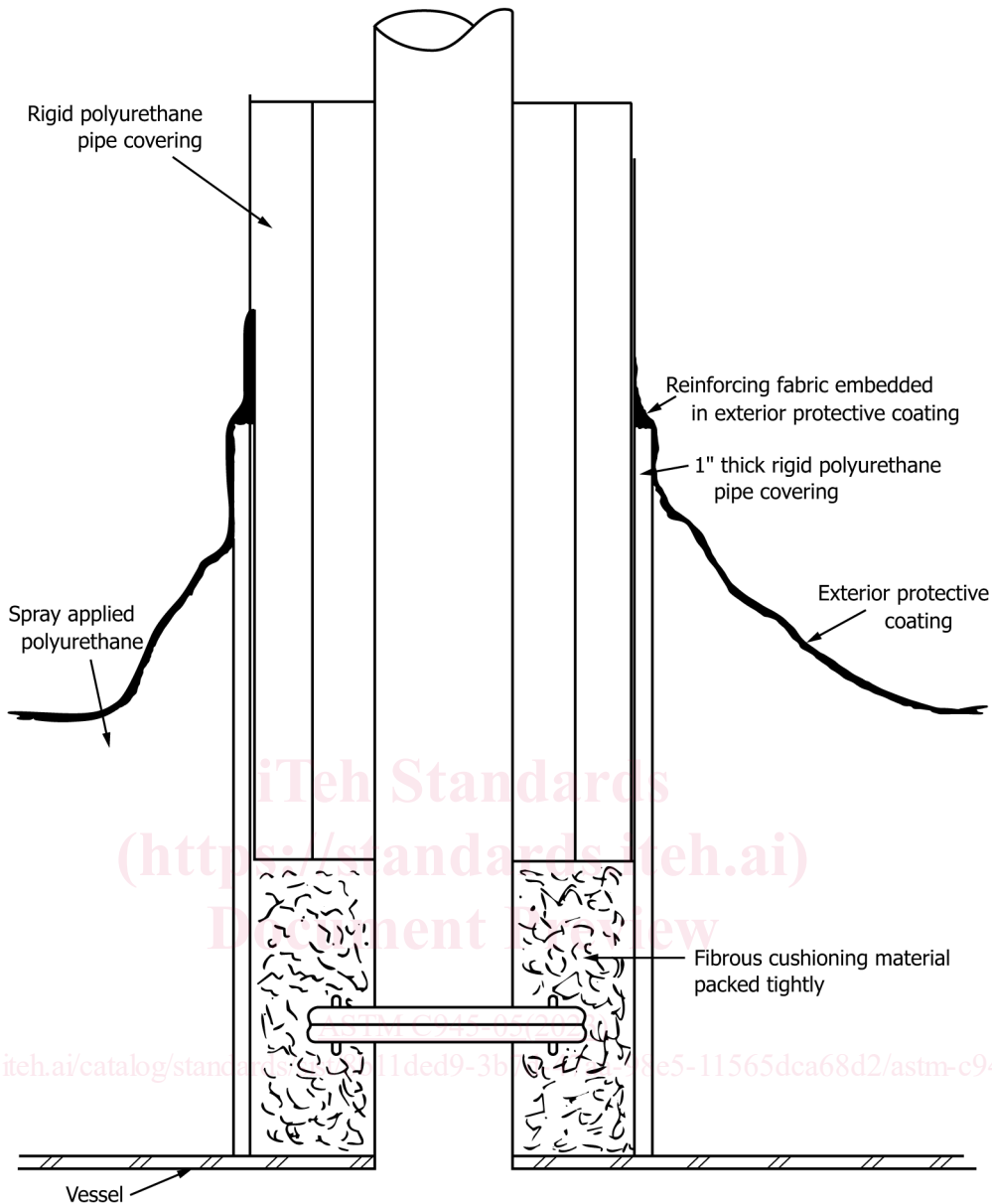

FIG. 1 Insulation of Vessel Nozzle

## 10. Thermal Barrier

### 10.1 Selection:

10.1.1 There are a number of materials that can be used to provide a thermal barrier for the foam.

10.1.2 Before selecting a thermal barrier, consult fire insurance and local building officials having jurisdiction for recommendations and approval.

10.2 *Application*— The thermal barrier shall be applied in accordance with the manufacturer’s recommendations using the proper fasteners or application techniques. Care must be exercised so as not to impair the integrity of any vapor barrier present.

## 11. Fire Safety

11.1 *Safety Hazards*— PUR/PIR cellular plastic materials used as insulation are combustible to varying degrees when exposed to an ignition source or high temperatures, or both.

11.2 It is important that *all persons* associated with the design, fabrication, storage, installation, and repair of such insulated equipment understand the fire hazards involved.

11.3 All foam-insulated tanks, vessels, and equipment must be identified and labeled to avoid welding or cutting without proper fire and safety precautions (see 9.3.7).

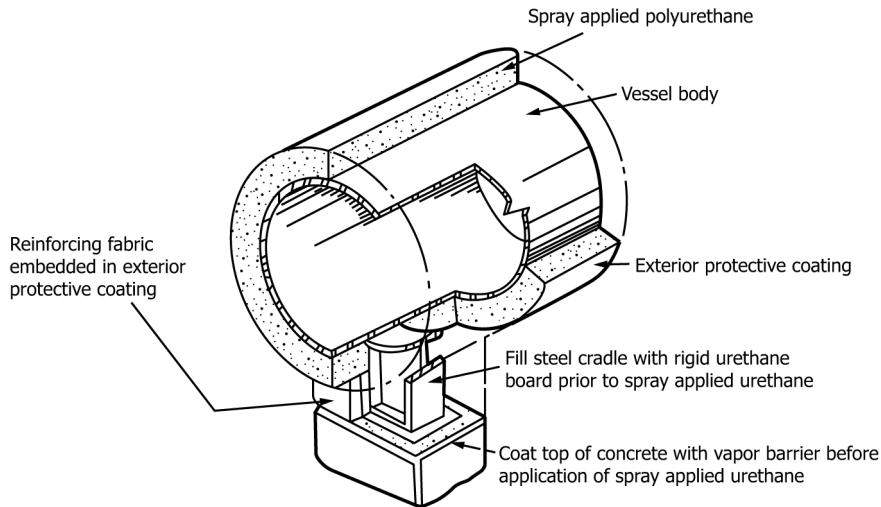

FIG. 2 Insulation of Vessel Cradles and Supports

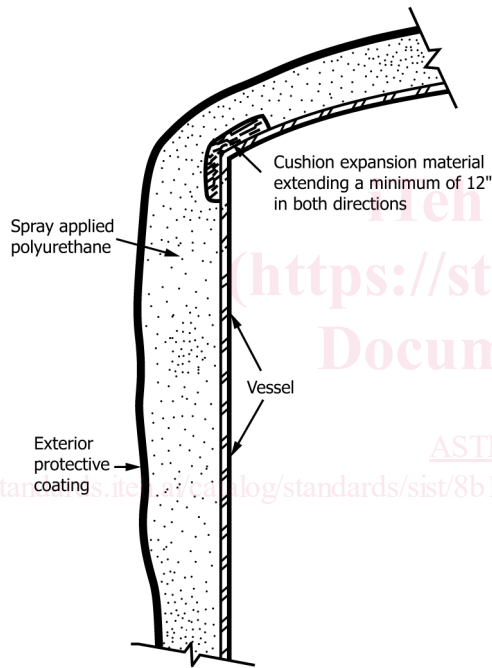

FIG. 3 Typical Insulation Shell and Roof Junction

**12. Safety Precautions in Handling and Spraying of PUR/PIR Systems**

12.1 During application there are numerous storage and application safety precautions that should be observed. Listed below are a few of these precautions. However, all safety precautions as outlined by the Spray Polyurethane Foam Alliance (SPFA)<sup>6</sup> the Alliance for the Polyurethane Industry (API)<sup>7</sup>, NFPA, OSHA, and the material manufacturer should be observed.

12.1.1 Forced-air supply masks shall be worn by all personnel involved in the application of foam. These respiratory protective devices shall be of the type approved by the Mining Enforcement and Safety Administration or the U.S. Department of Labor for the specific contaminant to which the employee is exposed. Employees required to use respiratory protective devices shall be instructed in their use and maintenance. Respiratory protective equipment shall be inspected regularly and maintained in good condition.

12.1.2 Eye and face protective equipment shall be provided and shall meet the requirements of ANSI Z87.1.

12.1.3 Protective clothing and gloves shall be worn. Skin areas not covered by clothing should be protected by a suitable cream.

12.1.4 During application of the spray foam, smoking, open flames, high temperatures, welding or electric sparks shall be strictly prohibited.

12.1.5 When opening component drums, begin by partially unscrewing the cap to vent the drum. Internal pressure can develop in drums that are at temperatures above 70°F (21°C). When opening “A” component drums, do not inhale vapors.

12.1.6 Empty nonreturnable “A” component (isocyanate) drums shall be decontaminated by filling them with water, preferably outdoors, and allowing them to stand for 48 h with the bung removed. Under no circumstances should the drums be sealed, stoppered, or closed. These drums shall then be drained and punched with a number of holes prior to disposal to prevent reuse.

12.1.7 The employer shall provide washing facilities in close proximity to the work site, and these facilities shall be equipped to remove all harmful substances with which an employee may come in contact.

**13. Keywords**

13.1 coating; outdoor service vessels; spray foam

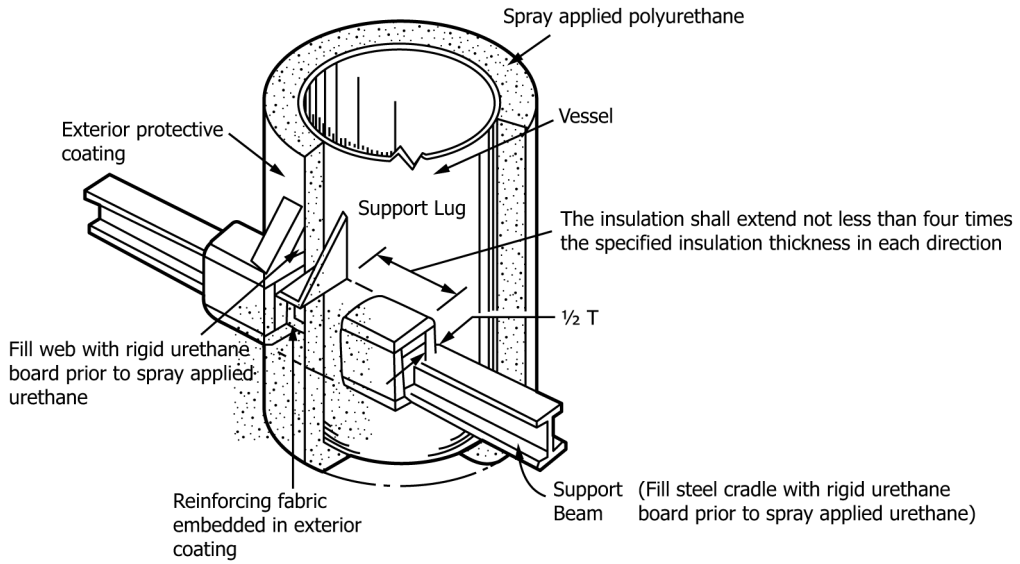

FIG. 4 Insulation of Vessel Lugs and Supporting Steel

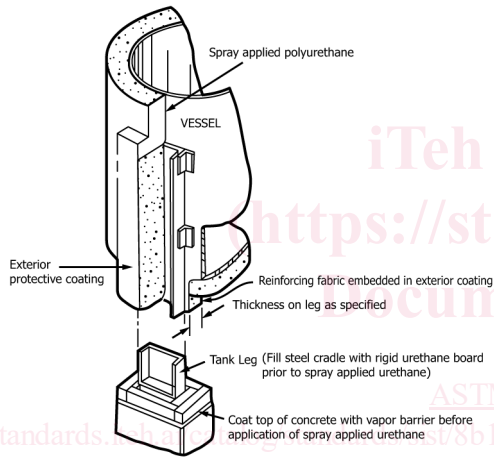

FIG. 5 Insulation of Vessel Leg

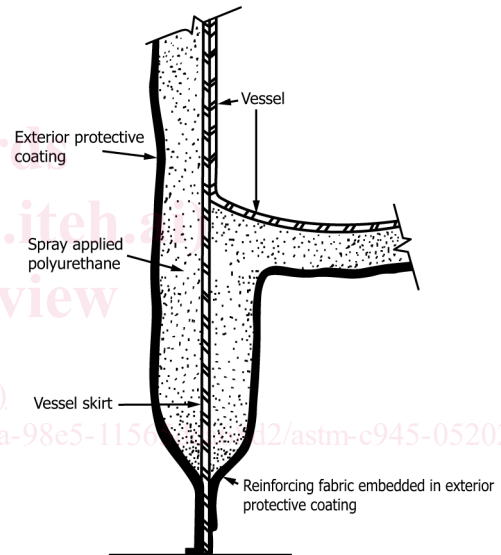

FIG. 6 Insulation of Vessel Skirt