



Designation: D256 – 23<sup>ε1</sup>

# Standard Test Methods for Determining the Izod Pendulum Impact Resistance of Plastics<sup>1</sup>

This standard is issued under the fixed designation D256; the number immediately following the designation indicates the year of original adoption or, in the case of revision, the year of last revision. A number in parentheses indicates the year of last reapproval. A superscript epsilon ( $\epsilon$ ) indicates an editorial change since the last revision or reapproval.

*This standard has been approved for use by agencies of the U.S. Department of Defense.*

<sup>ε1</sup> NOTE—Summary of Changes section was editorially added in April 2023.

## 1. Scope\*

1.1 These test methods cover the determination of the resistance of plastics to “standardized” (see [Note 1](#)) pendulum-type hammers, mounted in “standardized” machines, in breaking standard specimens with one pendulum swing (see [Note 2](#)). The standard tests for these test methods require specimens made with a milled notch (see [Note 3](#)). In Test Methods A, C, and D, the notch produces a stress concentration that increases the probability of a brittle, rather than a ductile, fracture. In Test Method E, the impact resistance is obtained by reversing the notched specimen 180° in the clamping vise. The results of all test methods are reported in terms of energy absorbed per unit of specimen width or per unit of cross-sectional area under the notch. (See [Note 4](#).)

NOTE 1—The machines with their pendulum-type hammers have been “standardized” in that they must comply with certain requirements, including a fixed height of hammer fall that results in a substantially fixed velocity of the hammer at the moment of impact. However, hammers of different initial energies (produced by varying their effective weights) are recommended for use with specimens of different impact resistance. Moreover, manufacturers of the equipment are permitted to use different lengths and constructions of pendulums with possible differences in pendulum rigidities resulting. (See [Section 5](#).) Be aware that other differences in machine design may exist. The specimens are “standardized” in that they are required to have one fixed length, one fixed depth, and one particular design of milled notch. The width of the specimens is permitted to vary between limits.

NOTE 2—Results generated using pendulums that utilize a load cell to record the impact force and thus impact energy, may not be equivalent to results that are generated using manually or digitally encoded testers that measure the energy remaining in the pendulum after impact.

NOTE 3—The notch in the Izod specimen serves to concentrate the stress, minimize plastic deformation, and direct the fracture to the part of the specimen behind the notch. Scatter in energy-to-break is thus reduced. However, because of differences in the elastic and viscoelastic properties of plastics, response to a given notch varies among materials. A measure

<sup>1</sup> These test methods are under the jurisdiction of ASTM Committee D20 on Plastics and are the direct responsibility of Subcommittee D20.10 on Mechanical Properties.

Current edition approved March 15, 2023. Published March 2023. Originally approved in 1926. Last previous edition approved in 2018 as D256-10(2018). DOI: 10.1520/D0256-23E01.

of a plastic’s “notch sensitivity” may be obtained with Test Method D by comparing the energies to break specimens having different radii at the base of the notch.

NOTE 4—Caution must be exercised in interpreting the results of these standard test methods. The following testing parameters may affect test results significantly:

- Method of fabrication, including but not limited to processing technology, molding conditions, mold design, and thermal treatments;
- Method of notching;
- Speed of notching tool;
- Design of notching apparatus;
- Quality of the notch;
- Time between notching and test;
- Test specimen thickness,
- Test specimen width under notch, and
- Environmental conditioning.

1.2 The values stated in SI units are to be regarded as standard. The values given in parentheses are for information only.

1.3 *This standard does not purport to address all of the safety concerns, if any, associated with its use. It is the responsibility of the user of this standard to establish appropriate safety, health, and environmental practices and determine the applicability of regulatory limitations prior to use.*

NOTE 5—These test methods resemble ISO 180:1993 in regard to title only. The contents are significantly different.

1.4 *This international standard was developed in accordance with internationally recognized principles on standardization established in the Decision on Principles for the Development of International Standards, Guides and Recommendations issued by the World Trade Organization Technical Barriers to Trade (TBT) Committee.*

## 2. Referenced Documents

- 2.1 *ASTM Standards:*<sup>2</sup>  
[D618 Practice for Conditioning Plastics for Testing](#)

<sup>2</sup> For referenced ASTM standards, visit the ASTM website, [www.astm.org](http://www.astm.org), or contact ASTM Customer Service at [service@astm.org](mailto:service@astm.org). For *Annual Book of ASTM Standards* volume information, refer to the standard’s Document Summary page on the ASTM website.

\*A Summary of Changes section appears at the end of this standard

- D883 Terminology Relating to Plastics
- D3641 Practice for Injection Molding Test Specimens of Thermoplastic Molding and Extrusion Materials
- D4066 Classification System for Nylon Injection and Extrusion Materials (PA)
- D5947 Test Methods for Physical Dimensions of Solid Plastics Specimens
- D6110 Test Method for Determining the Charpy Impact Resistance of Notched Specimens of Plastics
- E691 Practice for Conducting an Interlaboratory Study to Determine the Precision of a Test Method
- 2.2 ISO Standard:
- ISO 180:1993 Plastics—Determination of Izod Impact Strength of Rigid Materials<sup>3</sup>

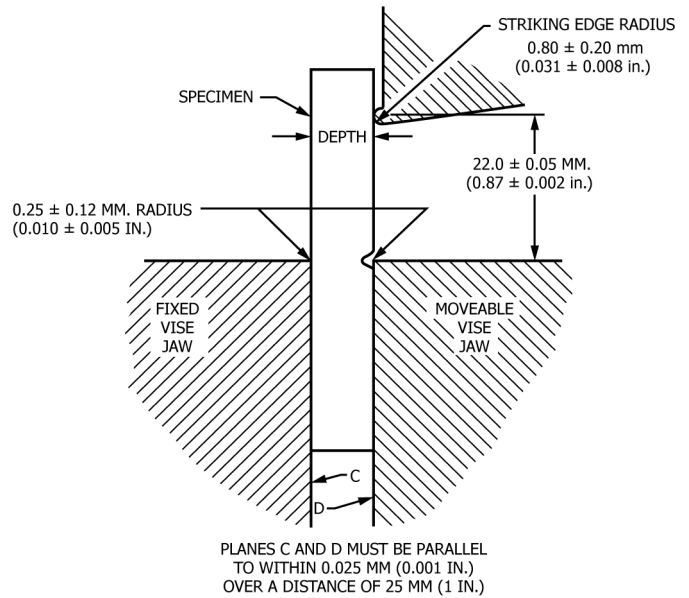

FIG. 1 Relationship of Vise, Specimen, and Striking Edge to Each Other for Izod Test Methods A and C

### 3. Terminology

3.1 *Definitions*—For definitions related to plastics see Terminology D883.

3.2 *Definitions of Terms Specific to This Standard:*

3.2.1 *cantilever*—a projecting beam clamped at only one end.

3.2.2 *notch sensitivity*—a measure of the variation of impact energy as a function of notch radius.

### 4. Types of Tests

4.1 Four similar methods are presented in these test methods. (See Note 6.) All test methods use the same testing machine and specimen dimensions. There is no known means for correlating the results from the different test methods.

NOTE 6—Previous versions of this test method contained Test Method B for Charpy. It has been removed from this test method and has been published as D6110.

4.1.1 In Test Method A, the specimen is held as a vertical cantilever beam and is broken by a single swing of the pendulum. The line of initial contact is at a fixed distance from the specimen clamp and from the centerline of the notch and on the same face as the notch.

4.1.2 Test Method C is similar to Test Method A, except for the addition of a procedure for determining the energy expended in tossing a portion of the specimen. The value reported is called the “estimated net Izod impact resistance.” Test Method C is preferred over Test Method A for materials that have an Izod impact resistance of less than 27 J/m (0.5 ft-lbf/in.) under notch. (See Appendix X4 for optional units.) The differences between Test Methods A and C become unimportant for materials that have an Izod impact resistance higher than this value.

4.1.3 Test Method D provides a measure of the notch sensitivity of a material. The stress-concentration at the notch increases with decreasing notch radius.

4.1.3.1 For a given system, greater stress concentration results in higher localized rates-of-strain. Since the effect of strain-rate on energy-to-break varies among materials, a measure of this effect may be obtained by testing specimens with

different notch radii. In the Izod-type test it has been demonstrated that the function, energy-to-break versus notch radius, is reasonably linear from a radius of 0.03 to 2.5 mm (0.001 to 0.100 in.), provided that all specimens have the same type of break. (See 5.8 and 22.1.)

4.1.3.2 For the purpose of this test, the slope,  $b$  (see 22.1), of the line between radii of 0.25 and 1.0 mm (0.010 and 0.040 in.) is used, unless tests with the 1.0-mm radius give “non-break” results. In that case, 0.25 and 0.50-mm (0.010 and 0.020-in.) radii may be used. The effect of notch radius on the impact energy to break a specimen under the conditions of this test is measured by the value  $b$ . Materials with low values of  $b$ , whether high or low energy-to-break with the standard notch, are relatively insensitive to differences in notch radius; while the energy-to-break materials with high values of  $b$  is highly dependent on notch radius. The parameter  $b$  cannot be used in design calculations but may serve as a guide to the designer and in selection of materials.

4.2 Test Method E is similar to Test Method A, except that the specimen is reversed in the vise of the machine 180° to the usual striking position, such that the striker of the apparatus impacts the specimen on the face opposite the notch. (See Fig. 1, Fig. 2.) Test Method E is used to give an indication of the unnotched impact resistance of plastics; however, results obtained by the reversed notch method may not always agree with those obtained on a completely unnotched specimen. (See 28.1.)<sup>4,5</sup>

### 5. Significance and Use

5.1 Before proceeding with these test methods, reference should be made to the specification of the material being tested.

<sup>3</sup> Available from American National Standards Institute (ANSI), 25 W. 43rd St., 4th Floor, New York, NY 10036, <http://www.ansi.org>.

<sup>4</sup> Supporting data giving results of the interlaboratory tests are available from ASTM Headquarters. Request RR:D20-1021.

<sup>5</sup> Supporting data giving results of the interlaboratory tests are available from ASTM Headquarters. Request RR:D20-1026.

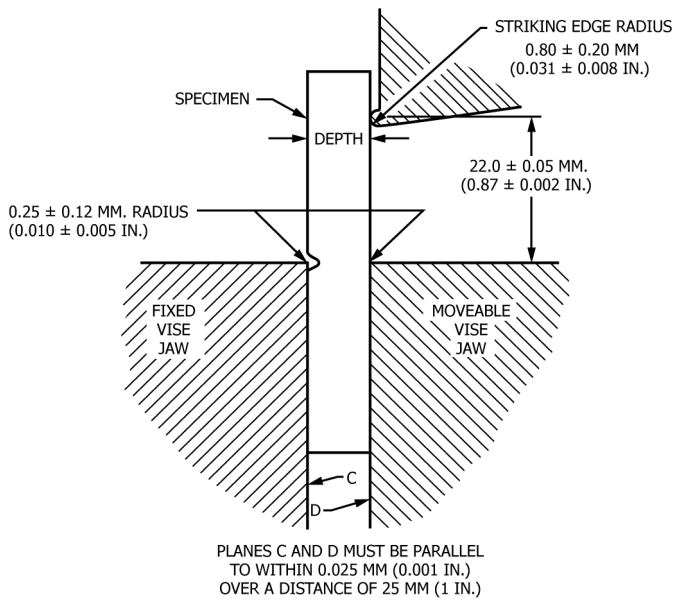

**FIG. 2 Relationship of Vise, Specimen, and Striking Edge to Each Other for Test Method E**

an Izod impact resistance of less than 27 J/m (0.5 ft-lbf/in.). (See Appendix X4 for optional units.) The toss correction obtained in Test Method C is only an approximation of the toss error, since the rotational and rectilinear velocities may not be the same during the re-toss of the specimen as for the original toss, and because stored stresses in the specimen may have been released as kinetic energy during the specimen fracture.

5.5 For tough, ductile, fiber filled, or cloth-laminated materials, the fracture propagation energy (see 5.3.2) may be large compared to the fracture initiation energy (see 5.3.1). When testing these materials, factors (see 5.3.2, 5.3.5, and 5.3.9) can become quite significant, even when the specimen is accurately machined and positioned and the machine is in good condition with adequate capacity. (See Note 7.) Bending (see 5.3.4) and indentation losses (see 5.3.8) may be appreciable when testing soft materials.

NOTE 7—Although the frame and base of the machine should be sufficiently rigid and massive to handle the energies of tough specimens without motion or excessive vibration, the design must ensure that the center of percussion be at the center of strike. Locating the striker precisely at the center of percussion reduces vibration of the pendulum arm when used with brittle specimens. However, some losses due to pendulum arm vibration, the amount varying with the design of the pendulum, will occur with tough specimens, even when the striker is properly positioned.

Any test specimen preparation, conditioning, dimensions, and testing parameters covered in the materials specification shall take precedence over those mentioned in these test methods. If there is no material specification, then the default conditions apply.

5.2 The pendulum impact test indicates the energy to break standard test specimens of specified size under stipulated parameters of specimen mounting, notching, and pendulum velocity-at-impact.

5.3 The energy lost by the pendulum during the breakage of the specimen is the sum of the following:

- 5.3.1 Energy to initiate fracture of the specimen;
- 5.3.2 Energy to propagate the fracture across the specimen;
- 5.3.3 Energy to throw the free end (or ends) of the broken specimen (“toss correction”);
- 5.3.4 Energy to bend the specimen;
- 5.3.5 Energy to produce vibration in the pendulum arm;
- 5.3.6 Energy to produce vibration or horizontal movement of the machine frame or base;
- 5.3.7 Energy to overcome friction in the pendulum bearing and in the indicating mechanism, and to overcome windage (pendulum air drag);
- 5.3.8 Energy to indent or deform plastically the specimen at the line of impact; and
- 5.3.9 Energy to overcome the friction caused by the rubbing of the striker (or other part of the pendulum) over the face of the bent specimen.

5.4 For relatively brittle materials, for which fracture propagation energy is small in comparison with the fracture initiation energy, the indicated impact energy absorbed is, for all practical purposes, the sum of factors 5.3.1 and 5.3.3. The toss correction (see 5.3.3) may represent a very large fraction of the total energy absorbed when testing relatively dense and brittle materials. Test Method C shall be used for materials that have

5.6 In a well-designed machine of sufficient rigidity and mass, the losses due to factors 5.3.6 and 5.3.7 should be very small. Vibrational losses (see 5.3.6) can be quite large when wide specimens of tough materials are tested in machines of insufficient mass, not securely fastened to a heavy base.

5.7 With some materials, a critical width of specimen may be found below which specimens will appear ductile, as evidenced by considerable drawing or necking down in the region behind the notch and by a relatively high-energy absorption, and above which they will appear brittle as evidenced by little or no drawing down or necking and by a relatively low-energy absorption. Since these methods permit a variation in the width of the specimens, and since the width dictates, for many materials, whether a brittle, low-energy break or a ductile, high energy break will occur, it is necessary that the width be stated in the specification covering that material and that the width be reported along with the impact resistance. In view of the preceding, one should not make comparisons between data from specimens having widths that differ by more than a few mils.

5.8 The type of failure for each specimen shall be recorded as one of the four categories listed as follows:

- C = *Complete Break*—A break where the specimen separates into two or more pieces.
- H = *Hinge Break*—An incomplete break, such that one part of the specimen cannot support itself above the horizontal when the other part is held vertically (less than 90° included angle).
- P = *Partial Break*—An incomplete break that does not meet the definition for a hinge break but has fractured at least 90 % of the distance between the vertex of the notch and the opposite side.
- NB = *Non-Break*—An incomplete break where the fracture extends less than 90 % of the distance between the vertex of the notch and the opposite side.

For tough materials, the pendulum may not have the energy necessary to complete the breaking of the extreme fibers and toss the broken piece or pieces. Results obtained from “non-break” specimens shall be considered a departure from standard and shall not be reported as a standard result. Impact resistance cannot be directly compared for any two materials that experience different types of failure as defined in the test method by this code. Averages reported must likewise be derived from specimens contained within a single failure category. This letter code shall suffix the reported impact identifying the types of failure associated with the reported value. If more than one type of failure is observed for a sample material, then the report will indicate the average impact resistance for each type of failure, followed by the percent of the specimens failing in that manner and suffixed by the letter code.

5.9 The value of the impact methods lies mainly in the areas of quality control and materials specification. If two groups of specimens of supposedly the same material show significantly different energy absorptions, types of breaks, critical widths, or critical temperatures, it may be assumed that they were made of different materials or were exposed to different processing or conditioning environments. The fact that a material shows twice the energy absorption of another under these conditions of test does not indicate that this same relationship will exist under another set of test conditions. The order of toughness may even be reversed under different testing conditions.

NOTE 8—A documented discrepancy exists between manual and digital impact testers, primarily with thermoset materials, including phenolics, having an impact value of less than 54 J/m (1 ft-lb/in.). Comparing data on the same material, tested on both manual and digital impact testers, may show the data from the digital tester to be significantly lower than data from a manual tester. In such cases a correlation study may be necessary to properly define the true relationship between the instruments.

**TEST METHOD A—CANTILEVER BEAM TEST**

**6. Apparatus**

6.1 The machine shall consist of a massive base on which is mounted a vise for holding the specimen and to which is connected, through a rigid frame and bearings, a pendulum-type hammer. (See 6.2.) The machine must also have a pendulum holding and releasing mechanism and a mechanism for indicating the breaking energy of the specimen.

6.2 A jig for positioning the specimen in the vise and graphs or tables to aid in the calculation of the correction for friction and windage also should be included. One type of machine is shown in Fig. 3. One design of specimen-positioning jig is illustrated in Fig. 4. Detailed requirements are given in subsequent paragraphs. General test methods for checking and calibrating the machine are given in Appendix X2. Additional instructions for adjusting a particular machine should be supplied by the manufacturer.

6.3 The pendulum shall consist of a single or multi-membered arm with a bearing on one end and a head, containing the striker, on the other. The arm must be sufficiently rigid to maintain the proper clearances and geometric relationships between the machine parts and the specimen and to minimize vibrational energy losses that are always included

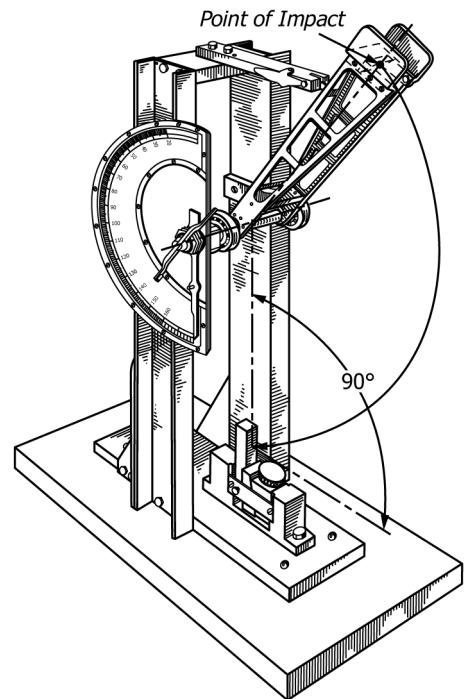

FIG. 3 Cantilever Beam (Izod-Type) Impact Machine



FIG. 4 Jig for Positioning Specimen for Clamping

in the measured impact resistance. Both simple and compound pendulum designs may comply with this test method.

6.4 The striker of the pendulum shall be hardened steel and shall be a cylindrical surface having a radius of curvature of  $0.80 \pm 0.20$  mm ( $0.031 \pm 0.008$  in.) with its axis horizontal and perpendicular to the plane of swing of the pendulum. The line of contact of the striker shall be located at the center of percussion of the pendulum within  $\pm 2.54$  mm ( $\pm 0.100$  in.) (See Note 9.) Those portions of the pendulum adjacent to the cylindrical striking edge shall be recessed or inclined at a

suitable angle so that there will be no chance for other than this cylindrical surface coming in contact with the specimen during the break.

NOTE 9—The distance from the axis of support to the center of percussion may be determined experimentally from the period of small amplitude oscillations of the pendulum by means of the following equation:

$$L = (g/4\pi^2)p^2$$

where:

- $L$  = distance from the axis of support to the center of percussion, m or (ft),
- $g$  = local gravitational acceleration (known to an accuracy of one part in one thousand),  $m/s^2$  or  $(ft/s^2)$ ,
- $\pi$  = 3.1416 ( $4\pi^2 = 39.48$ ), and
- $p$  = period, s, of a single complete swing (to and fro) determined by averaging at least 20 consecutive and uninterrupted swings. The angle of swing shall be less than  $5^\circ$  each side of center.

6.5 The position of the pendulum holding and releasing mechanism shall be such that the vertical height of fall of the striker shall be  $610 \pm 2$  mm ( $24.0 \pm 0.1$  in.). This will produce a velocity of the striker at the moment of impact of approximately 3.5 m (11.4 ft)/s. (See Note 10.) The mechanism shall be so constructed and operated that it will release the pendulum without imparting acceleration or vibration to it.

NOTE 10—

$$V = (2gh)^{0.5}$$

where:

- $V$  = velocity of the striker at the moment of impact (m/s),
  - $g$  = local gravitational acceleration ( $m/s^2$ ), and
  - $h$  = vertical height of fall of the striker (m).
- This assumes no windage or friction.

6.6 The effective length of the pendulum shall be between 0.33 and 0.40 m (12.8 and 16.0 in.) so that the required elevation of the striker may be obtained by raising the pendulum to an angle between  $60$  and  $30^\circ$  above the horizontal.

6.7 The machine shall be provided with a basic pendulum capable of delivering an energy of  $2.7 \pm 0.14$  J ( $2.00 \pm 0.10$  ft-lbf). This pendulum shall be used with all specimens that extract less than 85 % of this energy. Heavier pendulums shall be provided for specimens that require more energy to break. These may be separate interchangeable pendulums or one basic pendulum to which extra pairs of equal calibrated weights may be rigidly attached to opposite sides of the pendulum. It is imperative that the extra weights shall not significantly change the position of the center of percussion or the free-hanging rest point of the pendulum (that would consequently take the machine outside of the allowable calibration tolerances). A range of pendulums having energies from 2.7 to 21.7 J (2 to 16 ft-lbf) has been found to be sufficient for use with most plastic specimens and may be used with most machines. A series of pendulums such that each has twice the energy of the next will be found convenient. Each pendulum shall have an energy within  $\pm 0.5$  % of its nominal capacity.

6.8 A vise shall be provided for clamping the specimen rigidly in position so that the long axis of the specimen is vertical and at right angles to the top plane of the vise. (See Fig. 1.) This top plane shall bisect the angle of the notch with a

tolerance of 0.12 mm (0.005 in.). Correct positioning of the specimen is generally done with a jig furnished with the machine. The top edges of the fixed and moveable jaws shall have a radius of  $0.25 \pm 0.12$  mm ( $0.010 \pm 0.005$  in.). For specimens whose thickness approaches the lower limiting value of 3.00 mm (0.118 in.), means shall be provided to prevent the lower half of the specimen from moving during the clamping or testing operations (see Fig. 4 and Note 11.)

NOTE 11—Some plastics are sensitive to clamping pressure; therefore, cooperating laboratories should agree upon some means of standardizing the clamping force. One method is using a torque wrench on the screw of the specimen vise. If the faces of the vise or specimen are not flat and parallel, a greater sensitivity to clamping pressure may be evident. See the calibration procedure in Appendix X2 for adjustment and correction instructions for faulty instruments.

6.9 When the pendulum is free hanging, the striking surface shall come within 0.2 % of scale of touching the front face of a standard specimen. During an actual swing this element shall make initial contact with the specimen on a line  $22.00 \pm 0.05$  mm ( $0.87 \pm 0.002$  in.) above the top surface of the vise.

6.10 Means shall be provided for determining the energy expended by the pendulum in breaking the specimen. This is accomplished using either a pointer and dial mechanism or an electronic system consisting of a digital indicator and sensor (typically an encoder or resolver). In either case, the indicated breaking energy is determined by detecting the height of rise of the pendulum beyond the point of impact in terms of energy removed from that specific pendulum. Since the indicated energy must be corrected for pendulum-bearing friction, pointer friction, pointer inertia, and pendulum windage, instructions for making these corrections are included in 10.3 and Annex A1 and Annex A2. If the electronic display does not automatically correct for windage and friction, it shall be incumbent for the operator to determine the energy loss manually. (See Note 12.)

NOTE 12—Many digital indicating systems automatically correct for windage and friction. The equipment manufacturer may be consulted for details concerning how this is performed, or if it is necessary to determine the means for manually calculating the energy loss due to windage and friction.

6.11 The vise, pendulum, and frame shall be sufficiently rigid to maintain correct alignment of the hammer and specimen, both at the moment of impact and during the propagation of the fracture, and to minimize energy losses due to vibration. The base shall be sufficiently massive that the impact will not cause it to move. The machine shall be so designed, constructed, and maintained that energy losses due to pendulum air drag (windage), friction in the pendulum bearings, and friction and inertia in the indicating mechanism are held to a minimum.

6.12 A check of the calibration of an impact machine is difficult to make under dynamic conditions. The basic parameters are normally checked under static conditions; if the machine passes the static tests, then it is assumed to be accurate. The calibration procedure in Appendix X2 should be used to establish the accuracy of the equipment. However, for some machine designs it might be necessary to change the recommended method of obtaining the required calibration

**IZOD**

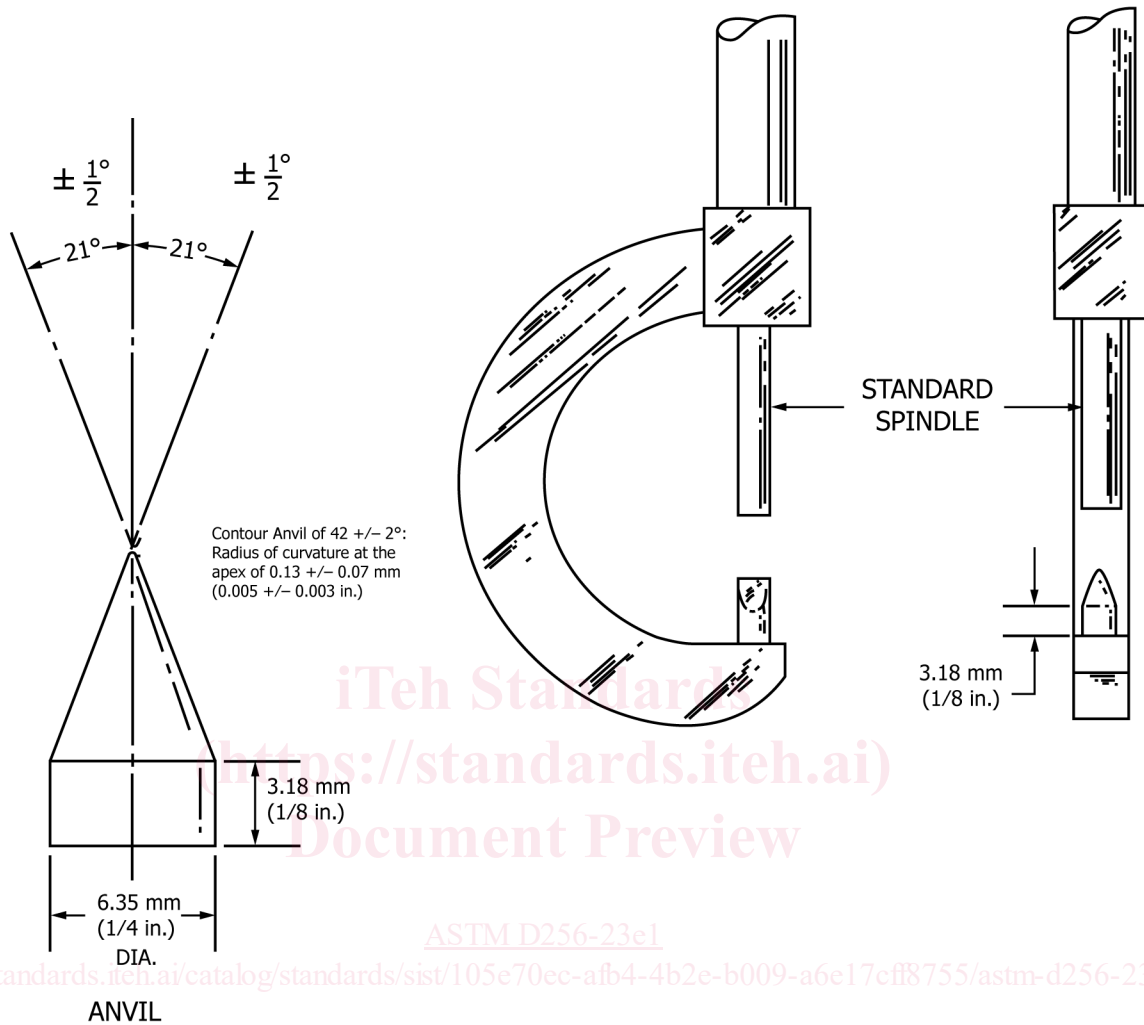

SCALE: 4:1

NOTE 1—These views not to scale.

NOTE 2—Micrometer to be satin-chrome finished with friction thimble.

NOTE 3—Special anvil for micrometer caliper 0 to 25.4 mm range (50.8 mm frame) (0 to 1 in. range (2-in. frame)).

NOTE 4—Anvil to be oriented with respect to frame as shown.

NOTE 5—Anvil and spindle to have hardened surfaces.

NOTE 6—Range: 0 to 25.4 mm (0 to 1 in. in thousandths of an inch).

NOTE 7—Adjustment must be at zero when spindle and anvil are in contact.

**FIG. 5 Early (ca. 1970) Version of a Notch-Depth Micrometer**

measurements. Other methods of performing the required checks may be substituted, provided that they can be shown to result in an equivalent accuracy. Appendix X1 also describes a dynamic test for checking certain features of the machine and specimen.

6.13 *Micrometers*—Apparatus for measurement of the width of the specimen shall comply with the requirements of Test Methods D5947. Apparatus for the measurement of the depth of plastic material remaining in the specimen under the notch

shall comply with requirements of Test Methods D5947, provided however that the one anvil or presser foot shall be a tapered blade conforming to the dimensions given in Fig. 5. The opposing anvil or presser foot shall be flat and conforming to Test Methods D5947.

**7. Test Specimens**

7.1 The test specimens shall conform to the dimensions and geometry of Fig. 6, except as modified in accordance with 7.2,

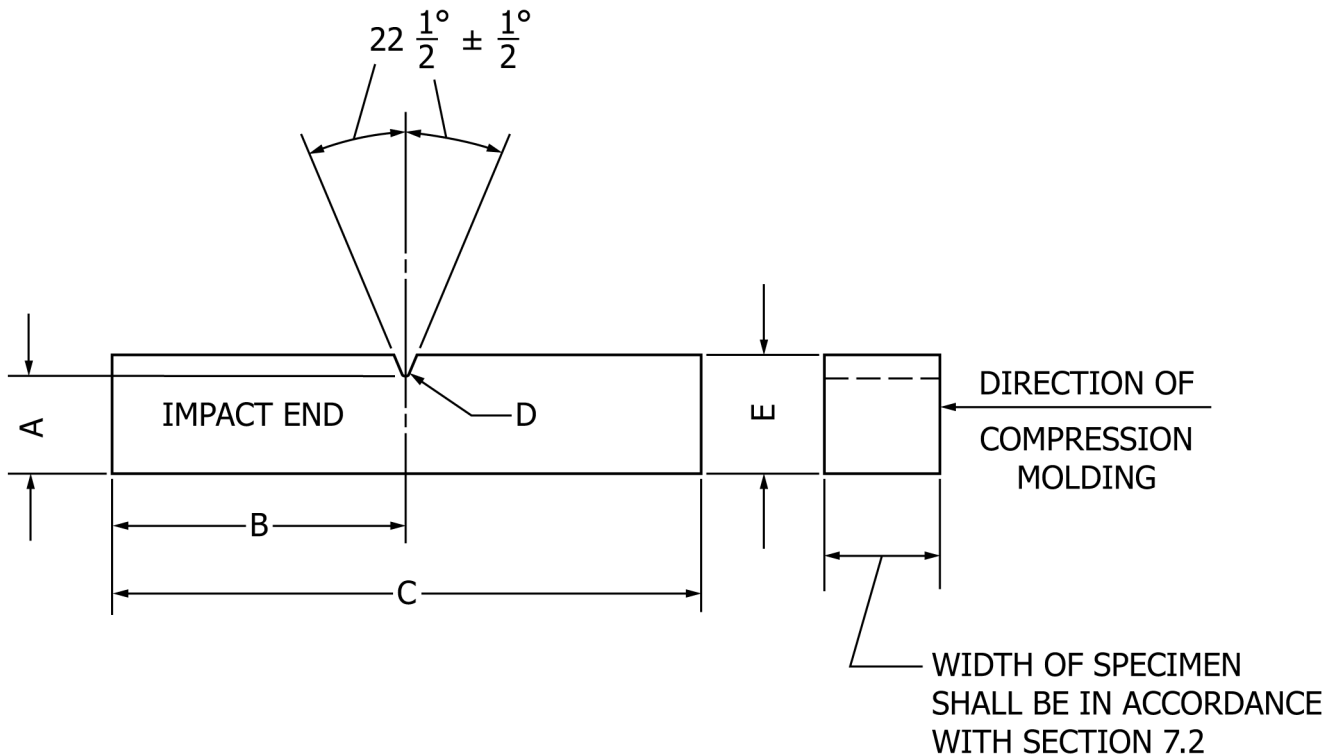

	mm	in.
A	10.16 ± 0.05	0.400 ± 0.002
B	31.8 ± 1.0	1.25 ± 0.04
C	63.5 ± 2.0	2.50 ± 0.08
D	0.25R ± 0.05	0.010R ± 0.002
E	12.70 ± 0.20	0.500 ± 0.008

FIG. 6 Dimensions of Izod-Type Test Specimen

7.3, 7.4, and 7.5. To ensure the correct contour and conditions of the specified notch, all specimens shall be notched as directed in Section 8.

7.1.1 Studies have shown that, for some materials, the location of the notch on the specimen and the length of the impacted end may have a slight effect on the measured impact resistance. Therefore, unless otherwise specified, care must be taken to ensure that the specimen conforms to the dimensions shown in Fig. 6 and that it is positioned as shown in Fig. 1 or Fig. 2.

7.2 Molded specimens shall have a width between 3.0 and 12.7 mm (0.118 and 0.500 in.). Use the specimen width as specified in the material specification or as agreed upon between the supplier and the customer. All specimens having one dimension less than 12.7 mm (0.500 in.) shall have the notch cut on the shorter side. Otherwise, all compression-molded specimens shall be notched on the side parallel to the direction of application of molding pressure. (See Fig. 6.)

NOTE 13—While subsection 7.5 requires perpendicular pairs of plane parallel surfaces, the common practice has been to accept the non-parallel drafted surfaces formed when directly injection molding specimens for Izod testing. Users must be aware that employing a trapezoidal section rather than a rectangular section may lead to data shifts and scatter. Unequal stress, created by clamping in the fracture region and dynamic twisting, caused by uneven striking of the specimen are prone to occur when the faces of the specimen are not parallel. Interlaboratory compari-

sons must clearly spell out the specimen preparation conditions.

7.2.1 Extreme care must be used in handling specimens less than 6.35 mm (0.250 in.) wide. Such specimens must be accurately positioned and supported to prevent twist or lateral buckling during the test. Some materials, furthermore, are very sensitive to clamping pressure (see Note 11).

7.2.2 A critical investigation of the mechanics of impact testing has shown that tests made upon specimens under 6.35 mm (0.250 in.) wide absorb more energy due to crushing, bending, and twisting than do wider specimens. Therefore, specimens 6.35 mm (0.250 in.) or over in width are recommended. The responsibility for determining the minimum specimen width shall be the investigator's, with due reference to the specification for that material.

7.2.3 Material specification should be consulted for preferred molding conditions. The type of mold and molding machine used and the flow behavior in the mold cavity will influence the impact resistance obtained. A specimen taken from one end of a molded plaque may give different results than a specimen taken from the other end. Cooperating laboratories should therefore agree on standard molds conforming to the material specification. Practice D3641 can be used as a guide for general molding tolerances, but refer to the material specification for specific molding conditions.

7.2.4 The impact resistance of a plastic material may be different if the notch is perpendicular to, rather than parallel to, the direction of molding. The same is true for specimens cut with or across the grain of an anisotropic sheet or plate.

7.3 For sheet materials, the specimens shall be cut from the sheet in both the lengthwise and crosswise directions unless otherwise specified. The width of the specimen shall be the thickness of the sheet if the sheet thickness is between 3.0 and 12.7 mm (0.118 and 0.500 in.). Sheet material thicker than 12.7 mm shall be machined down to 12.7 mm. Specimens with a 12.7-mm square cross section may be tested either edgewise or flatwise as cut from the sheet. When specimens are tested flatwise, the notch shall be made on the machined surface if the specimen is machined on one face only. When the specimen is cut from a thick sheet, notation shall be made of the portion of the thickness of the sheet from which the specimen was cut, for example, center, top, or bottom surface.

7.4 The practice of cementing, bolting, clamping, or otherwise combining specimens of substandard width to form a composite test specimen is not recommended and should be avoided since test results may be seriously affected by interface effects or effects of solvents and cements on energy absorption of composite test specimens, or both. However, if Izod test data on such thin materials are required when no other means of preparing specimens are available, and if possible sources of error are recognized and acceptable, the following technique of preparing composites may be utilized.

7.4.1 The test specimen shall be a composite of individual thin specimens totaling 6.35 to 12.7 mm (0.250 to 0.500 in.) in width. Individual members of the composite shall be accurately aligned with each other and clamped, bolted, or cemented together. The composite shall be machined to proper dimensions and then notched. In all such cases the use of composite specimens shall be noted in the report of test results.

7.4.2 Care must be taken to select a solvent or adhesive that will not affect the impact resistance of the material under test. If solvents or solvent-containing adhesives are employed, a conditioning procedure shall be established to ensure complete removal of the solvent prior to test.

7.5 Each specimen shall be free of twist (see [Note 14](#)) and shall have mutually perpendicular pairs of plane parallel surfaces and free from scratches, pits, and sink marks. The specimens shall be checked for compliance with these requirements by visual observation against straightedges, squares, and flat plates, and by measuring with micrometer calipers. Any specimen showing observable or measurable departure from one or more of these requirements shall be rejected or machined to the proper size and shape before testing.

**NOTE 14**—A specimen that has a slight twist to its notched face of 0.05 mm (0.002 in.) at the point of contact with the pendulum striking edge will be likely to have a characteristic fracture surface with considerable greater fracture area than for a normal break. In this case the energy to break and toss the broken section may be considerably larger (20 to 30 %) than for a normal break. A tapered specimen may require more energy to bend it in the vise before fracture.

## 8. Notching Test Specimens

8.1 Notching shall be done on a milling machine, engine lathe, or other suitable machine tool. Both the feed speed and

the cutter speed shall be constant throughout the notching operation (see [Note 15](#)). Provision for cooling the specimen with either a liquid or gas coolant is recommended. A single-tooth cutter shall be used for notching the specimen, unless notches of an equivalent quality can be produced with a multi-tooth cutter. Single-tooth cutters are preferred because of the ease of grinding the cutter to the specimen contour and because of the smoother cut on the specimen. The cutting edge shall be carefully ground and honed to ensure sharpness and freedom from nicks and burrs. Tools with no rake and a work relief angle of 15 to 20° have been found satisfactory.

**NOTE 15**—For some thermoplastics, cutter speeds from 53 to 150 m/min (175 to 490 ft/min) at a feed speed of 89 to 160 mm/min (3.5 to 6.3 in./min) without a water coolant or the same cutter speeds at a feed speed of from 36 to 160 mm/min (1.4 to 6.3 in./min) with water coolant produced suitable notches.

8.2 Specimens may be notched separately or in a group. However, in either case an unnotched backup or “dummy bar” shall be placed behind the last specimen in the sample holder to prevent distortion and chipping by the cutter as it exits from the last test specimen.

8.3 The profile of the cutting tooth or teeth shall be such as to produce a notch of the contour and depth in the test specimen as specified in [Fig. 6](#) (see [Note 16](#)). The included angle of the notch shall be  $45 \pm 1^\circ$  with a radius of curvature at the apex of  $0.25 \pm 0.05$  mm ( $0.010 \pm 0.002$  in.). The plane bisecting the notch angle shall be perpendicular to the face of the test specimen within 2°.

**NOTE 16**—There is evidence that notches in materials of widely varying physical dimensions may differ in contour even when using the same cutter.

8.4 The depth of the plastic material remaining in the specimen under the notch shall be  $10.16 \pm 0.05$  mm ( $0.400 \pm 0.002$  in.). This dimension shall be measured with apparatus in accordance with [6.13](#). The tapered blade will be fitted to the notch. The specimen will be approximately vertical between the anvils. For specimens with a draft angle, position edge of the non-cavity (wider edge) surface centered on the micrometer’s flat circular anvil.

8.5 Cutter speed and feed speed should be chosen appropriate for the material being tested since the quality of the notch may be adversely affected by thermal deformations and stresses induced during the cutting operation if proper conditions are not selected.<sup>6</sup> The notching parameters used shall not alter the physical state of the material such as by raising the temperature of a thermoplastic above its glass transition temperature. In general, high cutter speeds, slow feed rates, and lack of coolant induce more thermal damage than a slow cutter speed, fast feed speed, and the use of a coolant. Too high a feed speed/cutter speed ratio, however, may cause impacting and cracking of the specimen. The range of cutter speed/feed ratios possible to produce acceptable notches can be extended by the use of a suitable coolant. (See [Note 17](#).) In the case of new types of plastics, it is necessary to study the effect of variations in the notching conditions. (See [Note 18](#).)

<sup>6</sup> Supporting data are available from ASTM Headquarters. Request RR:D20-1066.



NOTE 17—Water or compressed gas is a suitable coolant for many plastics.

NOTE 18—Embedded thermocouples, or another temperature measuring device, can be used to determine the temperature rise in the material near the apex of the notch during machining. Thermal stresses induced during the notching operation can be observed in transparent materials by viewing the specimen at low magnification between crossed polars in monochromatic light.

8.6 A notching operation notches one or more specimens plus the “dummy bar” at a single pass through the notch. The specimen notch produced by each cutter will be examined after every 500 notching operations or less frequently if experience shows this to be acceptable. The notch in the specimen, made of the material to be tested, shall be inspected and verified. One procedure for the inspection and verification of the notch is presented in [Appendix X1](#). Each type of material being notched must be inspected and verified at that time. If the angle or radius does not fall within the specified limits for materials of satisfactory machining characteristics, then the cutter shall be replaced with a newly sharpened and honed one. (See [Note 19](#).)

NOTE 19—A carbide-tipped or industrial diamond-tipped notching cutter is recommended for longer service life.

## 9. Conditioning

9.1 *Conditioning*—Condition the test specimens at  $23 \pm 2^\circ\text{C}$  ( $73 \pm 3.6^\circ\text{F}$ ) and  $50 \pm 10\%$  relative humidity for not less than 40 h after notching and prior to testing in accordance with Procedure A of Practice [D618](#), unless it can be documented (between supplier and customer) that a shorter conditioning time is sufficient for a given material to reach equilibrium of impact resistance.

9.1.1 Note that for some hygroscopic materials, such as nylons, the material specifications (for example, Specification [D4066](#)) call for testing “dry as-molded specimens.” Such requirements take precedence over the above routine preconditioning to 50 % relative humidity and require sealing the specimens in water vapor-impermeable containers as soon as molded and not removing them until ready for testing.

9.2 *Test Conditions*—Conduct tests in the standard laboratory atmosphere of  $23 \pm 2^\circ\text{C}$  ( $73 \pm 3.6^\circ\text{F}$ ) and  $50 \pm 10\%$  relative humidity, unless otherwise specified in the material specification or by customer requirements. In cases of disagreement, the tolerances shall be  $\pm 1^\circ\text{C}$  ( $\pm 1.8^\circ\text{F}$ ) and  $\pm 5\%$  relative humidity.

## 10. Procedure

10.1 At least five and preferably ten or more individual determinations of impact resistance must be made on each sample to be tested under the conditions prescribed in Section 9. Each group shall consist of specimens with the same nominal width ( $\pm 0.13\text{ mm}$  ( $\pm 0.005\text{ in.}$ )). In the case of specimens cut from sheets that are suspected of being anisotropic, prepare and test specimens from each principal direction (lengthwise and crosswise to the direction of anisotropy).

10.2 Estimate the breaking energy for the specimen and select a pendulum of suitable energy. Use the lightest standard pendulum that is expected to break each specimen in the group

with a loss of not more than 85 % of its energy (see [Note 20](#)). Check the machine with the proper pendulum in place for conformity with the requirements of Section 6 before starting the tests. (See [Appendix X1](#).)

NOTE 20—Ideally, an impact test would be conducted at a constant test velocity. In a pendulum-type test, the velocity decreases as the fracture progresses. For specimens that have an impact energy approaching the capacity of the pendulum there is insufficient energy to complete the break and toss. By avoiding the higher 15 % scale energy readings, the velocity of the pendulum will not be reduced below 1.3 m/s (4.4 ft/s). On the other hand, the use of too heavy a pendulum would reduce the sensitivity of the reading.

10.3 If the machine is equipped with a mechanical pointer and dial, perform the following operations before testing the specimens. If the machine is equipped with a digital indicating system, follow the manufacturer’s instructions to correct for windage and friction. If excessive friction is indicated, the machine shall be adjusted before starting a test.

10.3.1 With the indicating pointer in its normal starting position but without a specimen in the vise, release the pendulum from its normal starting position and note the position the pointer attains after the swing as one reading of Factor A.

10.3.2 Without resetting the pointer, raise the pendulum and release again. The pointer should move up the scale an additional amount. Repeat ([10.3.2](#)) until a swing causes no additional movement of the pointer and note the final reading as one reading of Factor B (see [Note 21](#)).

10.3.3 Repeat the preceding two operations several times and calculate and record the average A and B readings.

NOTE 21—Factor B is an indication of the energy lost by the pendulum to friction in the pendulum bearings and to windage. The difference  $A - B$  is an indication of the energy lost to friction and inertia in the indicating mechanism. However, the actual corrections will be smaller than these factors, since in an actual test the energy absorbed by the specimen prevents the pendulum from making a full swing. Therefore, the indicated breaking energy of the specimen must be included in the calculation of the machine correction before determining the breaking energy of the specimen (see [10.8](#)). The A and B values also provide an indication of the condition of the machine.

10.3.4 If excessive friction is indicated, the machine shall be adjusted before starting a test.

10.4 Check the specimens for conformity with the requirements of Sections 7, 8, and [10.1](#).

10.5 Measure and record the width of each specimen after notching to the nearest 0.025 mm (0.001 in.). Measure the width in one location adjacent to the notch centered about the anticipated fracture plane.

10.6 Measure and record the depth of material remaining in the specimen under the notch of each specimen to the nearest 0.025 mm (0.001 in.). The tapered blade will be fitted to the notch. The specimen will be approximately vertical between the anvils. For specimens with a draft angle, position edge of the non-cavity (wider edge) surface centered on the micrometer’s flat circular anvil.

10.7 Position the specimen precisely (see [6.7](#)) so that it is rigidly, but not too tightly (see [Note 11](#)), clamped in the vise. Pay special attention to ensure that the “impacted end” of the

specimen as shown and dimensioned in Fig. 6 is the end projecting above the vise. Release the pendulum and record the indicated breaking energy of the specimen together with a description of the appearance of the broken specimen (see failure categories in 5.8).

10.8 Subtract the windage and friction correction from the indicated breaking energy of the specimen, unless determined automatically by the indicating system (that is, digital display or computer). If a mechanical dial and pointer is employed, use the *A* and *B* factors and the appropriate tables or the graph described in Annex A1 and Annex A2 to determine the correction. For those digital systems that do not automatically compensate for windage and friction, follow the manufacturer's procedure for performing this correction.

10.8.1 In other words, either manually or automatically, the windage and friction correction value is subtracted from the uncorrected, indicated breaking energy to obtain the new breaking energy. Compare the net value so found with the energy requirement of the hammer specified in 10.2. If a hammer of improper energy was used, discard the result and make additional tests on new specimens with the proper hammer. (See Annex A1 and Annex A2.)

10.9 Divide the net value found in 10.8 by the measured width of the particular specimen to obtain the impact resistance under the notch in J/m (ft·lbf/in.). If the optional units of kJ/m<sup>2</sup> (ft·lbf/in.<sup>2</sup>) are used, divide the net value found in 10.8 by the measured width and depth under the notch of the particular specimen to obtain the impact strength. The term, "depth under the notch," is graphically represented by Dimension A in Fig. 6. Consequently, the cross-sectional area (width times depth under the notch) will need to be reported. (See Appendix X4.)

10.10 Calculate the average Izod impact resistance of the group of specimens. However, only values of specimens having the same nominal width and type of break may be averaged. Values obtained from specimens that did not break in the manner specified in 5.8 shall not be included in the average. Also calculate the standard deviation of the group of values.

## 11. Report

11.1 Report the following information:

11.1.1 The test method used (Test Method A, C, D, or E),

11.1.2 Complete identification of the material tested, including type source, manufacturer's code number, and previous history,

11.1.3 A statement of how the specimens were prepared, the testing conditions used, the number of hours the specimens were conditioned after notching, and for sheet materials, the direction of testing with respect to anisotropy, if any,

11.1.4 The capacity of the pendulum in joules, or foot pound-force, or inch pound-force,

11.1.5 The width and depth under the notch of each specimen tested,

11.1.6 The total number of specimens tested per sample of material,

11.1.7 The type of failure (see 5.8),

11.1.8 The impact resistance must be reported in J/m (ft·lbf/in.); the optional units of kJ/m<sup>2</sup> (ft·lbf/in.<sup>2</sup>) may also be required (see 10.9),

11.1.9 The number of those specimens that resulted in failures which conforms to each of the requirement categories in 5.8,

11.1.10 The average impact resistance and standard deviation (in J/m (ft·lbf/in.)) for those specimens in each failure category, except non-break as presented in 5.8. Optional units (kJ/m<sup>2</sup> (ft·lbf/in.<sup>2</sup>)) may also need to be reported (see Appendix X4), and

11.1.11 The percent of specimens failing in each category suffixed by the corresponding letter code from 5.8.

## TEST METHOD C—CANTILEVER BEAM TEST FOR MATERIALS OF LESS THAN 27 J/m (0.5 ft·lbf/in.)

### 12. Apparatus

12.1 The apparatus shall be the same as specified in Section 6.

### 13. Test Specimens

13.1 The test specimens shall be the same as specified in Section 7.

### 14. Notching Test Specimens

14.1 Notching test specimens shall be the same as specified in Section 8.

### 15. Conditioning

15.1 Specimen conditioning and test environment shall be in accordance with Section 9.

### 16. Procedure

16.1 The procedure shall be the same as in Section 10 with the addition of a procedure for estimating the energy to toss the broken specimen part.

16.1.1 Conduct the testing procedure as specified in Section 10 using an intact specimen of the size and material type in question. Once the impact is completed retain the broken end of the specimen and leave the fixed portion of the specimen clamped in place.

16.1.1.1 The obtained result must be corrected for Friction/Windage in accordance with 10.3. Once the value is corrected it will become BE<sub>1</sub> for future calculations.

16.1.2 Reposition the broken end of the specimen on the clamped portion. Raise the pendulum to the initial start angle and then release it. Record the absorbed energy after the pendulum swings past the clamp as a measure of the energy required to toss the broken portion as TE<sub>1</sub> (toss energy).

16.1.2.1 If the broken piece of the specimen cannot be repositioned on the part remaining in the clamp due to elongation, jagged breaks or other issues, break another specimen to obtain usable pieces.

16.1.3 The toss energy (TE<sub>1</sub>) recorded in 16.1.2 includes the effects of energy losses discussed in 5.3, which includes windage. Net Izod Energy may be calculated from the following equation:

$$\text{Net Izod Energy} = \text{BE}_1 - \text{TE}_1 \quad (1)$$

where:

BE<sub>1</sub> = initial break energy corrected for friction and windage

$TE_I$  = toss energy

## 17. Report

17.1 Report the following information:

17.1.1 Same as 11.1.1,

17.1.2 Same as 11.1.2,

17.1.3 Same as 11.1.3,

17.1.4 Same as 11.1.4,

17.1.5 Same as 11.1.5,

17.1.6 Same as 11.1.6,

17.1.7 Same as 11.1.8,

17.1.8 Same as 11.1.10,

17.1.9 The estimated toss correction, expressed in terms of joule (J) or foot pound-force (ft·lbf).

17.1.10 The difference between the Izod impact energy and the toss correction energy is the net Izod energy. This value is divided by the specimen width (at the base of notch) to obtain the net Izod impact resistance for the report.

## TEST METHOD D—NOTCH RADIUS SENSITIVITY TEST

### 18. Apparatus

18.1 The apparatus shall be the same as specified in Section 6.

### 19. Test Specimens

19.1 The test specimens shall be the same as specified in Section 7. All specimens must be of the same nominal width, preferably 6.35-mm (0.25-in.).

### 20. Notching Test Specimens

20.1 Notching shall be done as specified in Section 8 and Fig. 6, except those ten specimens shall be notched with a radius of 0.25 mm (0.010 in.) and ten specimens with a radius of 1.0 mm (0.040 in.).

### 21. Conditioning

21.1 Specimen conditioning and test environment shall be in accordance with Section 9.

### 22. Procedure

22.1 Proceed in accordance with Section 10, testing ten specimens of each notch radius.

22.2 The average impact resistance of each group shall be calculated, except that within each group the type of break must be homogeneously C, H, C and H, or P.

22.3 If the specimens with the 0.25-mm (0.010-in.) radius notch do not break, the test is not applicable.

22.4 If any of ten specimens tested with the 1.0-mm (0.040-in.) radius notch fail as in category NB, non-break, the notch sensitivity procedure cannot be used without obtaining additional data. A new set of specimens should be prepared from the same sample, using a 0.50-mm (0.020-in.) notch radius and the procedure of 22.1 and 22.2 repeated.

## 23. Calculation

23.1 Calculate the slope of the line connecting the values for impact resistance for 0.25 and 1.0-mm notch radii or (0.010 and 0.040-in. notch radii) by the equation presented as follows. (If a 0.500-mm (0.020-in.) notch radius is substituted, adjust the calculation accordingly.)

$$b = (E_2 - E_1)/(R_2 - R_1)$$

where:

$E_2$  = average impact resistance for the larger notch, J/m of notch,

$E_1$  = average impact resistance for the smaller notch, J/m of notch,

$R_2$  = radius of the larger notch, mm, and

$R_1$  = radius of the smaller notch, mm.

Example:

$$\begin{aligned} E_{1.0} &= 330.95 \text{ J/m}; E_{0.25} = 138.78 \text{ J/m} \\ b &= (330.95 - 138.78 \text{ J/m})/(1.00 - 0.25 \text{ mm}) \\ b &= 192.17 \text{ J/m } 0.75 \text{ mm} = 256.23 \text{ J/m} \\ &\text{of notch per mm of radius} \end{aligned}$$

## 24. Report

24.1 Report the following information:

24.1.1 Same as 11.1.1,

24.1.2 Same as 11.1.2,

24.1.3 Same as 11.1.3,

24.1.4 Same as 11.1.4,

24.1.5 Same as 11.1.5,

24.1.6 Same as 11.1.6,

24.1.7 The average reversed notch impact resistance, in J/m (ft·lbf/in.) (see 5.8 for failure categories),

24.1.8 Same as 11.1.8,

24.1.9 Same as 11.1.9,

24.1.10 Same as 11.1.10, and

24.1.11 Same as 11.1.11.

24.1.12 Report the average value of  $b$  with its units, and the average Izod impact resistance for a 0.25-mm (0.010-in.) notch.

## TEST METHOD E—CANTILEVER BEAM REVERSED NOTCH TEST

### 25. Apparatus

25.1 The apparatus shall be the same as specified in Section 6.

### 26. Test Specimens

26.1 The test specimen shall be the same as specified in Section 7.

### 27. Notching Test Specimens

27.1 Notch the test specimens in accordance with Section 8.

### 28. Conditioning

28.1 Specimen conditioning and test environment shall be in accordance with Section 9.