



# Standard Specification for Poly (Vinyl Chloride) (PVC) Plastic Schedule 40 Drainage and DWV Fabricated Fittings<sup>1</sup>

This standard is issued under the fixed designation F1866; the number immediately following the designation indicates the year of original adoption or, in the case of revision, the year of last revision. A number in parentheses indicates the year of last reapproval. A superscript epsilon ( $\epsilon$ ) indicates an editorial change since the last revision or reapproval.

## 1. Scope\*

1.1 This specification covers requirements and test methods for fabricated poly(vinyl chloride) (PVC) plastic schedule 40 drainage and DWV fittings to be used with piping manufactured in accordance with Specifications D2665 or F891. These fabricated fittings are manufactured from pipe, or from a combination of pipe and injection molded parts.

1.2 The requirements of this specification are to provide fabricated PVC fittings suitable for drainage and venting of sanitary waste systems, storm water systems, and certain other liquid wastes. Fittings shall have solvent cement joints, gasket joints or a combination thereof.

1.3 The text of this specification references notes, footnotes, and appendixes that provide explanatory material. These notes and footnotes (excluding those in tables and figures) shall not be considered as requirements of the specification.

1.4 The values stated in inch-pound units are to be regarded as the standard. The values given in parentheses are provided for information only.

1.5 The following safety hazards caveat pertains only to the test method portion, Section 10, of this specification. *This standard does not purport to address all of the safety concerns, if any, associated with its use. It is the responsibility of the user of this standard to establish appropriate safety, health, and environmental practices and determine the applicability of regulatory limitations prior to use.*

1.6 *This international standard was developed in accordance with internationally recognized principles on standardization established in the Decision on Principles for the Development of International Standards, Guides and Recommendations issued by the World Trade Organization Technical Barriers to Trade (TBT) Committee.*

<sup>1</sup> This standard is under the jurisdiction of Committee F17 on Plastic Piping Systems and is the direct responsibility of Subcommittee F17.63 on DWV.

Current edition approved April 1, 2023. Published April 2023. Originally approved in 1998. Last previous edition approved in 2018 as F1866–18. DOI: 10.1520/F1866-23.

## 2. Referenced Documents

### 2.1 ASTM Standards:<sup>2</sup>

- D618 Practice for Conditioning Plastics for Testing
- D1600 Terminology for Abbreviated Terms Relating to Plastics
- D1784 Classification System and Basis for Specification for Rigid Poly(Vinyl Chloride) (PVC) Compounds and Chlorinated Poly(Vinyl Chloride) (CPVC) Compounds
- D1785 Specification for Poly(Vinyl Chloride) (PVC) Plastic Pipe, Schedules 40, 80, and 120
- D2122 Test Method for Determining Dimensions of Thermoplastic Pipe and Fittings
- D2564 Specification for Solvent Cements for Poly(Vinyl Chloride) (PVC) Plastic Piping Systems
- D2665 Specification for Poly(Vinyl Chloride) (PVC) Plastic Drain, Waste, and Vent Pipe and Fittings
- D2855 Practice for the Two-Step (Primer and Solvent Cement) Method of Joining Poly (Vinyl Chloride) (PVC) or Chlorinated Poly (Vinyl Chloride) (CPVC) Pipe and Piping Components with Tapered Sockets
- D3212 Specification for Joints for Drain and Sewer Plastic Pipes Using Flexible Elastomeric Seals
- F412 Terminology Relating to Plastic Piping Systems
- F477 Specification for Elastomeric Seals (Gaskets) for Joining Plastic Pipe
- F656 Specification for Primers for Use in Solvent Cement Joints of Poly(Vinyl Chloride) (PVC) Plastic Pipe and Fittings
- F891 Specification for Coextruded Poly(Vinyl Chloride) (PVC) Plastic Pipe With a Cellular Core
- F913 Specification for Thermoplastic Elastomeric Seals (Gaskets) for Joining Plastic Pipe

<sup>2</sup> For referenced ASTM standards, visit the ASTM website, www.astm.org, or contact ASTM Customer Service at service@astm.org. For *Annual Book of ASTM Standards* volume information, refer to the standard's Document Summary page on the ASTM website.

\*A Summary of Changes section appears at the end of this standard

### 3. Terminology

3.1 *Definitions*—Definitions are in accordance with Terminology **F412**, and abbreviations are in accordance with Terminology **D1600**, unless otherwise specified.

### 4. Materials and Manufacture

4.1 *Basic Materials*—The molded components for fabricated fittings shall be made of virgin or rework PVC compounds meeting or exceeding the requirements of Class 12454 as defined in Classification **D1784**.

4.1.1 The pipe shall be made of PVC that meets the requirements of the Materials Section of Specification **D1785** or **D2665**.

4.2 *Gaskets*—Elastomeric seals (gaskets) shall comply with the requirements of Specification **F477** or **F913**.

4.3 *Lubricant*—The lubricant used for field assembly shall be the type recommended by the manufacturer of the fitting. Prolonged exposure to the lubricant shall not damage the gasket, pipe, or fitting.

### 5. General Requirements

5.1 *Fabrication Joint Material*—The fabrication joint material or reinforcing overlays shall be of the type, strength, and properties suitable for intended fabrication. It is the decision of the manufacturer as to what material will be used. The PVC primer shall meet the requirements of Specification **F656**. The PVC solvent cement shall meet the requirements of Specification **D2564**.

5.2 *Heat Fusion Welds*—Fittings assembled using the heat fusion welding process shall meet all of the requirements of this specification.

5.3 *Pipe Performance*—Pipe that is used to fabricate fittings shall meet all of the schedule 40 requirements of Specification **D1785** or **D2665**.

5.4 *Waterway*—Fabricated fittings shall be constructed so that pipe ends of branches do not project into the waterway of the fitting body.

5.5 *Gasketed Joint System*—The joint shall display no leakage when tested in accordance with the requirements of Specification **D3212** when assembled in accordance with the

fitting manufacturer's recommendations. All surfaces of the joint that contact the gasket shall be smooth and free of imperfections, ridges, fractures or cracks that could affect the seal.

### 6. Dimensions and Permissible Variations

6.1 *Spigot Diameter*—The outside diameter and out-of-roundness of the fitting spigot shall meet the requirements of **Table 1** when measured in accordance with **10.1.1**

6.2 *Spigot Length*—The spigot length shall meet the requirements as given in **Table 1** when measured in accordance with **10.1.2**.

6.3 *Wall Thickness*—The minimum wall thickness of the fitting shall meet the requirements of **Table 1** when measured in accordance with **10.1.3**. In the case of fittings fabricated from pipe sections, the thickness of the wall in the bell and branch area shall be considered satisfactory if it was formed from pipe meeting those requirements.

6.4 *Solvent Cement Sockets:*

6.4.1 *Socket Diameter*—The inside diameter of the fitting socket shall meet the requirements as specified in **Table 2** when measured in accordance with **10.1.4**.

6.4.2 *Socket Depths*—The socket depth shall meet the requirements as given in **Table 2** when measured in accordance with **10.1.5**.

6.5 *Gasket Joint Sockets*—The minimum depth and maximum projection for gasket sockets, show in **Fig. 1**, shall meet the dimensional values given in **Table 3**. Measurements shall be made in accordance with Test Method **D2122**. All other dimensions shall be in accordance with the manufacturer's specifications.

### 7. Properties

7.1 *Resistance to Bending*—Fabricated fittings shall be tested in accordance with **10.2**. The bond shall not show any sign of cracking, splitting, or separation as seen by the naked eye.

7.2 *Leak Test*—After completing the Resistance to Bending test, the fabrication joint shall be checked for leakage in accordance with **10.3**. Fittings subjected to these tests shall be discarded.

**TABLE 1 Pipe/Fitting Dimensions**

Nominal Pipe Size	Average O.D.					
	Minimum in. (mm)	Maximum in. (mm)	Out-of-Roundness, in. (mm)	Min. Wall Thickness, in. (mm)	Min. Spigot Length, in. (mm)	
1½	1.894 (48.11)	1.906 (48.41)	0.024 (0.61)	0.145 (3.68)	1.500 (38.10)	
2	2.369 (60.18)	2.381 (60.48)	0.024 (0.61)	0.154 (3.91)	2.000 (50.8)	
3	3.492 (88.70)	3.508 (89.10)	0.030 (0.76)	0.216 (5.49)	3.000 (76.2)	
4	4.491 (114.07)	4.509 (114.53)	0.030 (0.76)	0.237 (6.02)	4.000 (101.60)	
6	6.614 (168.00)	6.636 (168.55)	0.050 (1.27)	0.280 (7.11)	6.000 (152.40)	
8	8.610 (218.69)	8.640 (219.46)	0.150 (3.81)	0.322 (8.18)	6.000 (152.40)	
10	10.735 (272.67)	10.765 (273.43)	0.150 (3.81)	0.365 (9.27)	7.500 (190.50)	
12	12.735 (323.47)	12.765 (324.23)	0.150 (3.81)	0.406 (10.31)	8.500 (215.90)	
14	13.985 (355.22)	14.015 (355.98)	0.200 (5.08)	0.437 (11.10)	9.000 (228.60)	
16	15.981 (405.92)	16.019 (406.88)	0.320 (8.13)	0.500 (12.70)	10.000 (254.00)	
18	17.981 (456.72)	18.019 (457.68)	0.360 (9.14)	0.562 (14.27)	12.000 (304.80)	
20	19.977 (507.42)	20.023 (508.58)	0.400 (10.16)	0.593 (15.06)	12.000 (304.80)	
24	23.969 (608.81)	24.031 (610.39)	0.480 (12.19)	0.687 (17.45)	14.000 (355.60)	

TABLE 2 Socket Dimensions

Nominal Pipe Size	Avg. Entrance Diameter, A	Avg. Bottom Diameter, B	Minimum Socket Depth, C		Out-of-Roundness
			in. (mm)		
1 1/2	1.915 +0.010/-0.005 (48.64 +0.25/-0.13)	1.894 ±0.006 (48.11 ±0.15)	0.687 (17.44)		0.024 (0.61)
2	2.390 +0.010/-0.005 (60.71 +0.25/-0.13)	2.369 ± 0.006 (60.17 ± 0.15)	0.750 (19.05)		0.024 (0.61)
3	3.520 +0.010/-0.005 (89.41 +0.25/-0.13)	3.492 ±0.008 (88.70 ± 0.20)	1.500 (38.10)		0.030 (0.76)
4	4.518 ±0.009 (114.76 ±0.23)	4.491 ±0.009 (114.07 ±0.23)	2.000 (50.80)		0.048 (1.22)
6	6.647 ±0.011 (168.83 ±0.28)	6.614 ± 0.011 (168.00 ±0.28)	3.000 (76.20)		0.082 (2.08)
8	8.655 ±0.015 (219.84 ±0.38)	8.610 ±0.015 (218.69 ±0.38)	4.000 (101.6)		0.120 (3.05)
10	10.776 ±0.015 (273.71 ±0.38)	10.737 ±0.015 (272.72 ±0.38)	5.000 (127.00)		0.130 (3.30)
12	12.778 ±0.015 (324.56 ±0.38)	12.736 ±0.015 (323.49 ±0.38)	6.000 (152.40)		0.150 (3.81)
14	14.035 ±0.015 (356.49 ±0.38)	13.985 ±0.015 (355.22 ±0.38)	7.000 (177.80)		0.150 (3.81)
16	16.045 ±0.015 (410.08 ±0.38)	15.980 ±0.015 (405.89 ±0.38)	8.000 (203.20)		0.160 (4.06)
18	18.055 ±0.020 (458.60 ±0.51)	17.980 ±0.020 (456.69 ±0.51)	9.000 (228.60)		0.180 (4.57)
20	20.065 ±0.025 (509.65 ±0.64)	19.980 ±0.025 (507.49 ±0.64)	10.000 (254.00)		0.200 (5.08)
24	24.075 ±0.030 (611.51 ±0.76)	23.970 ±0.030 (608.84 ±0.76)	12.000 (304.80)		0.240 (6.10)

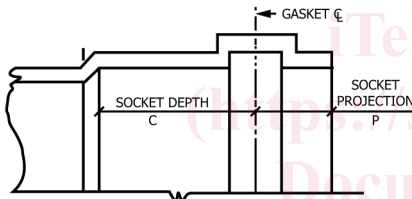

FIG. 1 Gasket-Joint Dimensions

TABLE 3 Gasket Joint —Dimensions

Nominal Pipe Size	Socket	
	Depth "C" Min in. (mm)	Projection "P" Max. in. (mm)
4	1.50 (38.1)	2.00 (50.8)
6	2.15 (54.6)	2.25 (57.2)
8	2.50 (63.5)	2.75 (69.0)
10	2.92 (74.2)	3.25 (82.6)
12	3.10 (78.7)	3.50 (88.9)
14	3.30 (83.8)	4.00 (101.6)
16	3.60 (91.4)	4.25 (108.0)
18	3.90 (99.1)	4.50 (114.3)
20	4.20 (106.7)	5.00 (127.0)
24	4.95 (125.7)	5.50 (139.7)

considered unacceptable. The fittings shall be uniform in color, opacity, density, and other physical properties.

9. Sample and Conditioning

9.1 Sampling—The selection of fitting samples shall be as agreed upon between the purchaser and the manufacturer. In case of no prior agreement, samples selected by the testing laboratory shall be deemed adequate.

9.2 Conditioning:

9.2.1 Referee Testing—The specimen shall be conditioned in accordance with Procedure A of Practice D618 at 73 °F ± 4 °F (23 °C ± 2 °C) and 50 % ± 10 % relative humidity for not less than 40 h prior to test. Tests shall be conducted at the same conditions of temperature and humidity, unless otherwise specified.

9.2.2 Quality Control Tests—The specimens shall be conditioned for a minimum of 4 h in air or 1 h in water at 73 °F ± 4 °F (23 °C ± 2 °C). The specimens shall be tested at 73 °F ± 4 °F (23 °C ± 2 °C) without regard to humidity.

10. Test Methods

10.1 Dimensions and Tolerances:

10.1.1 Spigot Diameter—Determine the average outside diameter of the spigot in accordance with Test Method D2122. A measurement apparatus accurate to 0.001 in. (0.02 mm) shall be used.

10.1.2 Spigot Length—A measurement apparatus accurate to 0.031 in. (1 mm) shall be used.

10.1.3 Wall Thickness—Measure in accordance with Test Method D2122. A measurement apparatus accurate to 0.001 in. (0.02 mm) shall be used.

7.3 Solvent Weld Bond Area—The bond area for the manufacturer’s solvent welds shall be in accordance with the manufacturer’s standard design dimensions and tolerances, and the insertion bond depth shall be not less than 0.75 in. all around the perimeter. Joints shall be made in accordance with Practice D2855.

8. Workmanship, Finish, and Appearance

8.1 The fittings shall be homogeneous throughout, and free from visible cracks, holes, foreign inclusions, or other defects. Scratches deeper than 10 % of the wall thickness shall be

10.1.4 *Socket Diameter*—Measure in accordance with Test Method D2122. A measurement apparatus accurate to 0.001 in. (0.02 mm) shall be used. Reference Fig. 2 for measuring locations.

10.1.5 *Socket Depth*—A measurement apparatus accurate to 0.031 in. (1 mm) shall be used. Reference Fig. 2 for measuring locations.

10.2 *Branch Bending:*

10.2.1 *Forty-Five Degree Wyes*—A fabricated fitting branch shall be subjected to a load as illustrated in Fig. 3 using suggested alternatives 1, 2, or 3. The load shall result in a bending moment of 62.0 ft·lbf (84.32 Nm) per circumferential 1 in. (25 mm) of the branch diameter. The bending moments for NPS 1½ through 24 branches are displayed in Table 4.

10.2.2 *Tees*—The fitting shall be subjected to the test described in 10.2.1. Using the alternative 4 loading arrangement illustrated in Fig. 3, apply the bending moment shown in Table 4.

10.3 *Leak Test*—After the fitting passes the branch bend test, subject it to a 25 psi hydrostatic test and check the fabrication joint for leaks. Visible leaks in the fabrication joint constitute a failure. After completing these tests (10.2 and 10.3), the fitting shall be discarded.

11. Inspection

11.1 Inspection and testing of the product shall be as agreed upon between the purchaser and the manufacturer as part of the purchase contract.

11.2 Inspection and testing by the purchaser shall not relieve the manufacturer of the responsibility of furnishing product meeting the requirements of this specification.

11.3 If purchaser inspection is specified, the manufacturer shall notify the purchaser in advance as to the date, time, and place of testing the product so that the purchaser may be represented at the test.

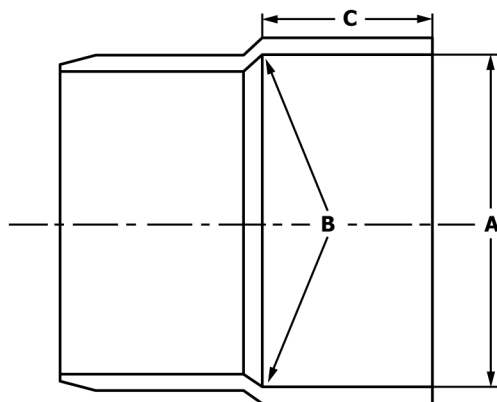

FIG. 2 Socket Dimensions

11.4 The inspector shall have free access to those areas of the manufacturer’s plant that are involved in inspection and product testing to be performed under this specification. The manufacturer shall provide the inspector with facilities for determining whether the product meets the requirements of this specification.

12. Retest and Rejection

12.1 If the results of any test(s) do not meet the requirements of this specification, the test(s) shall be conducted again only by agreement between the purchaser and manufacturer. Under such agreement, minimum requirements shall not be lowered, changed, or modified, nor shall specification limits be changed. If, upon retest, failure occurs, the quantity of product represented by the test(s) does not meet the requirements of this specification.

13. Certification

13.1 When specified in the purchase order or contract, the purchaser shall be furnished certification that the samples representing each lot have been either tested or inspected as directed in this specification and the requirements have been met. When specified in the purchase order or contract, a report of the test results shall be furnished.

14. Product Marking

14.1 Fittings in compliance with this specification shall be clearly marked as follows:

- 14.1.1 Manufacturer’s name or trademark,
- 14.1.2 Nominal size,
- 14.1.3 Material designation PVC,
- 14.1.4 Specification designation (ASTM F1866),
- 14.1.5 Schedule 40 drainage or DWV, and
- 14.1.6 Applicable code body approvals.

14.2 The markings or engravings shall be in such a manner that they remain legible during storage, transportation, and installation.

15. Packaging and Package Marking

15.1 All fittings shall be packaged and marked for standard commercial shipment, unless otherwise specified.

15.2 The manufacturer’s code as to day, month, year, and plant location shall be indicated.

16. Quality Assurance

16.1 *Quality Assurance*—When the product is marked with this specification designation, F1866, the manufacturer affirms that the product was manufactured, sampled, inspected, and tested in accordance with this specification and has been found to meet the requirements of this specification.

17. Keywords

17.1 drainage; DWV; fabricated fittings; plastic; PVC; Schedule 40