



Standard Specification for Plastic Insert Fittings For SDR9 Cross-linked Polyethylene (PEX) and Polyethylene of Raised Temperature (PE-RT) Tubing¹

This standard is issued under the fixed designation F2735; the number immediately following the designation indicates the year of original adoption or, in the case of revision, the year of last revision. A number in parentheses indicates the year of last reapproval. A superscript epsilon (ϵ) indicates an editorial change since the last revision or reapproval.

1. Scope*

1.1 This specification establishes requirements for sulfone plastic insert fittings and copper crimp rings for three sizes ($\frac{1}{2}$, $\frac{3}{4}$, and 1) of cross-linked polyethylene (PEX) tubing that meet the requirements for Specification F876 or F3253, and polyethylene of raised temperature (PE-RT) tubing that meet the requirements of Specification F2623. These fittings are intended for use in 100 psi (690 kPa) cold- and hot-water distribution systems operating at temperatures up to and including 180 °F (82 °C). Included are the requirements for material, molded part properties, performance, workmanship, dimensions, and markings to be used on the fittings and rings.

1.2 *Units*—The values stated in inch-pound units are to be regarded as standard. The values given in parentheses are mathematical conversions to SI units that are provided for information only and are not considered standard.

1.3 The following is an index of the appendix in this specification.

GO/NO-GO Crimp Gauges [Appendix X1](#)

1.4 The following precautionary caveat pertains only to the test method portions, Sections 11 and 12, of this specification. *This standard does not purport to address all of the safety concerns, if any, associated with its use. It is the responsibility of the user of this standard to establish appropriate safety, health, and environmental practices and determine the applicability of regulatory limitations prior to use.*

1.5 *This international standard was developed in accordance with internationally recognized principles on standardization established in the Decision on Principles for the Development of International Standards, Guides and Recommendations issued by the World Trade Organization Technical Barriers to Trade (TBT) Committee.*

¹ This specification is under the jurisdiction of ASTM Committee F17 on Plastic Piping Systems and is the direct responsibility of Subcommittee F17.10 on Fittings.

Current edition approved April 1, 2023. Published April 2023. Originally approved in 2008. Last previous edition approved in 2021 as F2735–21. DOI:10.1520/F2735–23.

2. Referenced Documents

2.1 ASTM Standards:²

- D1600 Terminology for Abbreviated Terms Relating to Plastics
- D2122 Test Method for Determining Dimensions of Thermoplastic Pipe and Fittings
- D2837 Test Method for Obtaining Hydrostatic Design Basis for Thermoplastic Pipe Materials or Pressure Design Basis for Thermoplastic Pipe Products
- D6394 Classification System for and Basis for Specification for Sulfone Plastics (SP)
- F412 Terminology Relating to Plastic Piping Systems
- F876 Specification for Crosslinked Polyethylene (PEX) Tubing
- F877 Specification for Crosslinked Polyethylene (PEX) Hot- and Cold-Water Distribution Systems
- F1498 Specification for Taper Pipe Threads 60° for Thermoplastic Pipe and Fittings
- F1807 Specification for Metal Insert Fittings Utilizing a Copper Crimp Ring, or Alternate Stainless Steel Clamps, for SDR9 Cross-linked Polyethylene (PEX) Tubing and SDR9 Polyethylene of Raised Temperature (PE-RT) Tubing
- F1960 Specification for Cold Expansion Fittings with PEX Reinforcing Rings for Use with Cross-linked Polyethylene (PEX) and Polyethylene of Raised Temperature (PE-RT) Tubing
- F2623 Specification for Polyethylene of Raised Temperature (PE-RT) Systems for Non-Potable Water Applications
- F3253 Specification for Crosslinked Polyethylene (PEX) Tubing with Oxygen Barrier for Hot- and Cold-Water Hydronic Distribution Systems

2.2 ASME Standard:³

- B1.20.1 Pipe Threads General Purpose Inch

² For referenced ASTM standards, visit the ASTM website, www.astm.org, or contact ASTM Customer Service at service@astm.org. For *Annual Book of ASTM Standards* volume information, refer to the standard's Document Summary page on the ASTM website.

³ Available from American Society of Mechanical Engineers (ASME), ASME International Headquarters, Two Park Ave., New York, NY 10016-5990, <http://www.asme.org>.

*A Summary of Changes section appears at the end of this standard

2.3 NSF International Standard⁴

NSF/ANSI Standard No. 14 for Plastic Piping Components and Related Materials

NSF/ANSI Standard No. 61 for Drinking Water System Components-Health Effects

2.4 ISO Standards:⁵

ISO 9080 Plastics piping and ducting systems -- Determination of the long-term hydrostatic strength of thermoplastics materials in pipe form by extrapolation

ISO 12162 Thermoplastics materials for pipes and fittings for pressure applications –Classification, designation and design coefficient

that is, hot and cold potable water plumbing systems, in addition to the performance requirements of this specification. Those qualifying characteristics include but are not limited to an established hydrostatic design basis (HDB) in accordance with Test Method D2837 or a minimum required stress (MRS) in accordance with ISO 9080/ ISO 12162 and a demonstration of resistance to the long-term effects of those chemicals normally found in water conveyed in these applications (for example, disinfectants such as sodium hypochlorite used in potable water) at the maximum temperature stated in this specification.

6. Molded Part Properties

6.1 *Insert Crush*—The fitting insert shall not crack, split, or shatter when tested in accordance with 12.1.

6.2 *Splay*—The molded part shall be free of visible splay excepting some slight blushing at the gate location.

7. Performance Requirements

7.1 *General*—All performance tests shall be performed on assemblies of fittings, crimp rings, and PEX tubing. Fittings and crimp rings shall meet the material and dimensional requirements of this standard. PEX tubing shall meet the requirements of Specification F876 or F3253. Assembly of test specimens shall be in accordance with Section 10. Use separate sets of assemblies for each performance test requirement.

7.2 The following sections of Specification F877 constitute a part of this specification:

- 7.2.1 Hydrostatic Burst,
- 7.2.2 Hydrostatic Sustained Pressure Strength,
- 7.2.3 Thermocycling,
- 7.2.4 Excessive Temperature-Pressure Capability, and
- 7.2.5 Test Methods.

7.3 In addition, when a section with a title identical to that referenced in 7.2 appears in this specification, it contains additional requirements that supplement those appearing in Specification F877.

8. Dimensions

8.1 *Dimensions and Tolerances*—The dimensions and tolerances of fittings shall be as shown in Fig. 1, when measured in accordance with 11.1

8.1.1 *Alignment*—The maximum angular variation of any opening shall not exceed 1° off the true centerline axis.

8.1.2 *Tapered Threads*—Fitting threads shall be American National Standard Taper Pipe Thread Form conforming to Specification F1498.

8.1.3 *Straight Threads*—Straight pipe threads, intended for the making of a gasketed seal with taper pipe threads, shall be American National Straight Pipe Thread for Fixtures (free-fitting mechanical joints), NPSM, and conform to ASME B1.20.1.

9. Workmanship, Finish, and Appearance

9.1 The sealing surfaces of the insert shall be smooth and free of foreign material. The fitting walls shall be free of cracks, holes, blisters, voids, foreign inclusions, or other defects that are visible to the unaided eye and that affect the wall integrity.

3. Terminology

3.1 *Definitions*—Definitions are in accordance with Terminology F412 and abbreviations are in accordance with Terminology D1600, unless otherwise indicated.

4. Classification

4.1 This specification governs one class of fittings and copper crimp rings suitable for use with nominal size 1/2, 3/4, and 1 size PEX tubing that meets the requirements of Specification F876 or F3253 and polyethylene of raised temperature (PE-RT) tubing that meets the requirements of Specification F2623.

5. Ordering Information

5.1 *Material*—Fittings shall be molded from sulfone plastic (SP) as specified in Classification D6394. The material shall be polyphenylsulfone (group 03, class 1, grade 1 or 2) or unreinforced polyphenylsulfone/polysulfone blends (group 04, Class 2, grade 1) or reworked plastic in accordance with 5.1.1. Colored products can exceed the maximum specific gravity listed provided that they comply with all other properties listed in Classification D6394 Table SP.

5.1.1 *Rework Material*—Clean rework material of the same commercial designation, generated from the manufacturer's own production may be used by the same manufacturer, provided the fittings meet all of the requirements of this specification. Reworked material shall not be introduced at a ratio exceeding 25 %.

5.2 *Potable Water Requirements*—Products intended for the transport of potable water shall be evaluated, tested and certified for conformance with NSF/ANSI Standard No. 61 or the health effects portion of NSF/ANSI Standard No. 14 by an acceptable certifying organization when required by the regulatory authority having jurisdiction.

5.3 *Crimp Rings*—Crimp rings shall be manufactured and marked in accordance with the requirements of Specification F1807.

NOTE 1—All wetted and pressure carrying polymeric materials used to manufacture the fittings should be suitable for the intended applications,

⁴ Available from NSF International, P.O. Box 130140, 789 N. Dixboro Rd., Ann Arbor, MI 48113-0140, <http://www.nsf.org>.

⁵ Available from International Organization for Standardization (ISO), ISO Central Secretariat, BIBC II, Chemin de Blandonnet 8, CP 401, 1214 Vernier, Geneva, Switzerland, <http://www.iso.org>.

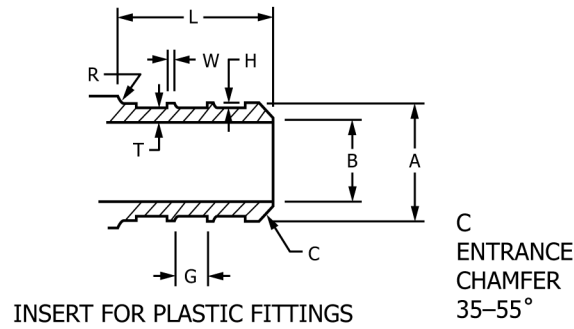

Size (in.)	A	B ^A	L ^B	H	Number of Ribs ^C	W	G	T	R	Maximum Flash and Mismatch Total on Crest Diameter ^{E,F}
1/2	0.471 ± .004	0.315	0.480 ± .004	0.011	2	0.02- 0.04	0.114±.004	0.059	0.03	0.005
3/4	0.667 ± .004	0.490	0.480 ± .004	0.011	2	0.02- 0.04	0.114±.004	0.067	0.03	0.005
1	0.856 ± .004	0.645	0.480 ± .004	0.011	2	0.02- 0.04	0.114±.004	0.084	0.03	0.005

^A The minimum ID shall be maintained through the insert length and into the fitting, intersecting and minimum ID of the other fitting.
^B Fitting shall be designed with sufficient overall dimensions to allow proper use of crimp tool without interference with previously completed crimps on the same fitting.
^C Lead chamfer area is not considered rib.
^D Applies to entire fitting and not just insert area.
^E The maximum flash and mismatch at the root diameter between the ribs may not exceed 30% of rib height
^F The total flash and mismatch is assumed to be the difference between the dimensions X and Y (See Fig. 2a.) These dimensions may be measured with appropriate callipers or micrometres. See Fig. 2b for a graphic definition of flash and mismatch created by imperfection in die half interfaces.

FIG. 1 Fitting Insert Dimensions and Tolerances

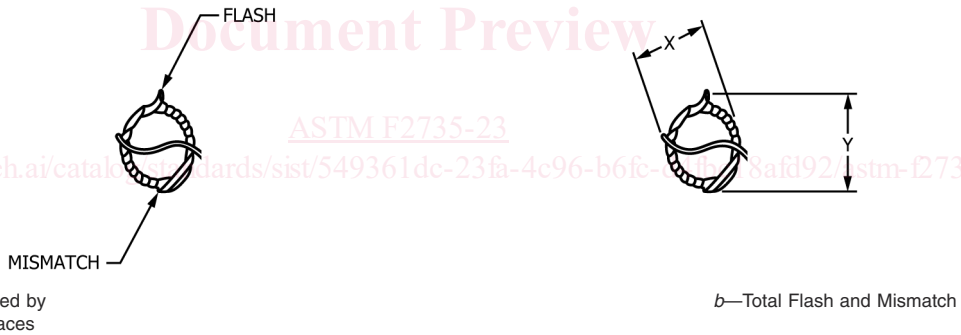

FIG. 2 Fitting Insert Dimensions and Tolerances

9.2 Except for the insert, the molded part shall be free of flash in excess of 0.005 in. (0.13 mm). Flash, mismatch, and witness mark requirements for the insert shall be in accordance with Fig. 1.

10. Assembly

10.1 Crimp Joints—Insert fittings shall be joined to PEX tubing by the compression of a copper crimp ring around the outer circumference of the tubing forcing the tubing material into annular spaces formed by ribs on the fitting. Insert fittings and crimp rings shall meet the dimensional and material requirements of this standard. PEX tubing shall meet the requirements of Specification F876 or F3253. The dimensions and out-of-roundness of the crimp ring after it has been crimped shall be in accordance with Table 1.

TABLE 1 Crimp Ring Dimensions After Crimping on Tube/Fitting Assembly

Nominal Tube Size Insert End	Final Crimped Outside Diameter ^{A,B}	
	Minimum, in. (mm)	Maximum, in. (mm)
1/2	0.700 (17.8)	07.15 (18.2)
3/4	0.945 (24.0)	0.960 (24.4)
1	1.175 (29.8)	1.190 (30.2)

^A For all diameters except for the area of scoring caused by the crimping tool.
^B The maximum out of roundness as measured by the difference between the minimum crimped outside diameter and the maximum crimped outside diameter shall not exceed 0.006 in. 90.150 mm).

10.1.1 Crimping Procedure—To affix the insert fitting to the tubing with the crimp ring, the crimping procedure shall be as follows: slide the crimp ring onto the tubing, insert the ribbed end of the fitting into the end of the tubing until the tubing

contacts the shoulder of the fitting or tube stop. The crimp ring shall then be positioned on the tubing so the edge of the crimp ring contacts the shoulder of the fitting or tube stop. The jaws of the crimping tool shall be centered over the crimp ring and the tool shall be held so that the crimping jaws are approximately perpendicular to the axis of the barb. The jaws of the crimping tool shall be closed around the crimp ring, compressing the crimp ring onto the tubing. The crimp ring shall not be crimped more than once. Each crimp shall be checked to determine conformance to the after crimped dimensional requirements of [Table 1](#).

11. Test Methods

11.1 *Dimensions*—Any randomly selected fitting or fittings and crimp ring or crimp rings shall be used to determine dimensions. Measurements shall be made in accordance with Test Method [D2122](#). Determine the diameters by making measurements at four locations spaced at approximately 45° apart around the circumference.

12. Molded Part Properties Test Methods

12.1 *Insert Crush Test*—Under ambient conditions, test six fittings of each size in accordance with [12.1.1](#).

12.1.1 *Procedure*—Using a bench vise or other suitable compression device, place the insert of the fitting between the jaws of the vise. Close the jaws of the vise deforming the insert until the opposing inside walls of the insert touch. The insert shall not crack, split, or shatter, see [Fig. 3](#). Separation of the insert from the fitting body at the shoulder shall not be considered a failure, see [Fig. 4](#).

13. Restest

13.1 If any failure occurs, a retest shall be conducted only if agreed upon between the purchaser and the seller. Failure in the retest is cause for rejection of the shipment.

14. Quality Assurance

14.1 When the product or product packing is marked with the ASTM designation F2735, the manufacturer affirms that the product was manufactured, inspected, sampled, and tested in accordance with this specification and has been found to meet the requirements of this specification.

15. Product Marking

15.1 *Quality of Marking*—The marking shall be applied to the fittings in such a manner that it remains legible after installation and inspection.

15.2 *Content of Marking:*

15.2.1 Marking on fittings shall include manufacturer’s name or trademark, or some other identifying mark, material designation, and ASTM F2735.

15.2.1.1 Where recessed marking is used on fittings, care shall be taken to see that in no case shall the marking cause cracks or reduce the wall thickness below the minimum specified.

15.2.2 Marking on packaging shall include manufacturer’s name, fitting size, and ASTM F2735.

16. Keywords

16.1 cold- and hot-water distribution; copper crimp rings; cross-linked polyethylene; plastic insert fittings; PEX; PE-RT

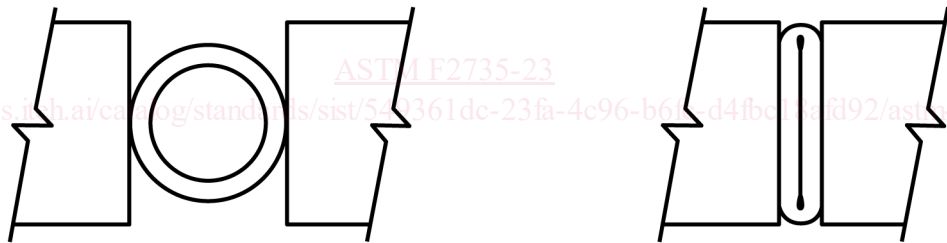

1– Place the insert in a vise or other suitable device

2 – Close the vice jaws until the inside walls touch.

FIG. 3 Insert Crush Test