



# Standard Specification for Plastic Press Insert Fittings with Factory Assembled Stainless Steel Press Sleeve for SDR9 Cross-linked Polyethylene (PEX) Tubing and SDR9 Polyethylene of Raised Temperature (PE-RT) Tubing<sup>1</sup>

This standard is issued under the fixed designation F3348; the number immediately following the designation indicates the year of original adoption or, in the case of revision, the year of last revision. A number in parentheses indicates the year of last reapproval. A superscript epsilon ( $\epsilon$ ) indicates an editorial change since the last revision or reapproval.

## 1. Scope\*

1.1 This specification covers plastic press insert fittings with factory assembled stainless steel press sleeves incorporating 3 view holes and a tool locator ring. These fittings are for use with cross-linked polyethylene (PEX) tubing in nominal sizes  $\frac{3}{8}$ ,  $\frac{1}{2}$ ,  $\frac{3}{4}$ , 1,  $1\frac{1}{4}$ ,  $1\frac{1}{2}$ , and 2 that meet the requirements for Specification F876 or F3253 and for use with polyethylene of raised temperature (PE-RT) tubing in nominal sizes  $\frac{3}{8}$ ,  $\frac{1}{2}$ ,  $\frac{3}{4}$ , 1,  $1\frac{1}{4}$ ,  $1\frac{1}{2}$ , and 2 that meet the requirements of Specification F2769. These fittings are intended for use in 100 psi (690 kPa) cold- and hot-water distribution systems operating at temperatures up to and including 180 °F (82 °C). Included are the requirements for material, molded part properties, performance, workmanship, dimensions, and markings to be used on the fittings and sleeves.

1.1.1 When used with PEX tubing in accordance with Specification F876, the fittings covered by this specification are intended for use in, but not limited to, residential and commercial, hot- and cold-potable water distribution systems, water service lines, building supply lines, reclaimed water, fire protection, radiant heating and cooling systems, hydronic distribution systems, snow and ice melting systems, geothermal ground loops, district heating, turf conditioning, compressed air distribution and building services pipe.

1.1.2 When used with PEX tubing in accordance with Specification F3253, the fittings covered by this specification are intended for use in residential and commercial hydronic heating and cooling systems.

1.1.3 When used with PE-RT tubing in accordance with Specification F2769, the fittings covered by this specification are intended for use in residential and commercial, hot- and cold-potable water distribution systems, and building supply lines.

<sup>1</sup> This test method is under the jurisdiction of ASTM Committee F17 on Plastic Piping Systems and is the direct responsibility of Subcommittee F17.10 on Fittings.

Current edition approved April 1, 2023. Published April 2023. Originally approved in 2018. Last previous edition approved in 2023 as F3348–23. DOI: 10.1520/F3348–23A

1.2 *Units*—The values stated in inch-pound units are to be regarded as standard. The values given in parentheses are mathematical conversions to SI units that are provided for information only and are not considered standard.

1.3 *This standard does not purport to address all of the safety concerns, if any, associated with its use. It is the responsibility of the user of this standard to establish appropriate safety, health, and environmental practices and determine the applicability of regulatory limitations prior to use.*

1.4 *This international standard was developed in accordance with internationally recognized principles on standardization established in the Decision on Principles for the Development of International Standards, Guides and Recommendations issued by the World Trade Organization Technical Barriers to Trade (TBT) Committee.*

## 2. Referenced Documents

### 2.1 ASTM Standards:<sup>2</sup>

- A269/A269M Specification for Seamless and Welded Austenitic Stainless Steel Tubing for General Service
- D1600 Terminology for Abbreviated Terms Relating to Plastics
- D2122 Test Method for Determining Dimensions of Thermoplastic Pipe and Fittings
- D2837 Test Method for Obtaining Hydrostatic Design Basis for Thermoplastic Pipe Materials or Pressure Design Basis for Thermoplastic Pipe Products
- D6394 Classification System for and Basis for Specification for Sulfone Plastics (SP)
- E92 Test Methods for Vickers Hardness and Knoop Hardness of Metallic Materials
- F412 Terminology Relating to Plastic Piping Systems
- F876 Specification for Crosslinked Polyethylene (PEX) Tubing

<sup>2</sup> For referenced ASTM standards, visit the ASTM website, www.astm.org, or contact ASTM Customer Service at service@astm.org. For *Annual Book of ASTM Standards* volume information, refer to the standard's Document Summary page on the ASTM website.

\*A Summary of Changes section appears at the end of this standard

**F877** Specification for Crosslinked Polyethylene (PEX) Hot- and Cold-Water Distribution Systems

**F1960** Specification for Cold Expansion Fittings with PEX Reinforcing Rings for Use with Cross-linked Polyethylene (PEX) and Polyethylene of Raised Temperature (PE-RT) Tubing

**F2769** Specification for Polyethylene of Raised Temperature (PE-RT) Plastic Hot and Cold-Water Tubing and Distribution Systems

**F3253** Specification for Crosslinked Polyethylene (PEX) Tubing with Oxygen Barrier for Hot- and Cold-Water Hydronic Distribution Systems

2.2 NSF/ANSI Standards:<sup>3</sup>

**Standard 14** Plastic Piping Components and Related Materials

**Standard 61** Drinking Water System Components-Health Effects

**Standard 372** Drinking Water System Components-Lead Content

2.3 ISO Standards:<sup>4</sup>

**ISO 9080** Plastics piping and ducting systems -- Determination of the long-term hydrostatic strength of thermoplastics materials in pipe form by extrapolation

**ISO 12162** Thermoplastics materials for pipes and fittings for pressure applications –Classification, designation and design coefficient

3. Terminology

3.1 *Definitions*—Unless otherwise specified, definitions, abbreviations and initialisms are in accordance with Terminology **F412** and Terminology **D1600**.

<sup>3</sup> Available from NSF International, P.O. Box 130140, 789 N. Dixboro Rd., Ann Arbor, MI 48105, <http://www.nsf.org>.

<sup>4</sup> Available from International Organization for Standardization (ISO), ISO Central Secretariat, BIBC II, Chemin de Blandonnet 8, CP 401, 1214 Vernier, Geneva, Switzerland, <http://www.iso.org>.

3.2 *Definitions*:

3.2.1 *plastic press insert fitting, n*—A type of piping component that is pushed into the open end of the plastic tubing and attaches by mechanically pressing and deforming an outer stainless steel sleeve over the outside diameter of the plastic tubing. The seal is realized between the outer diameter of the insert fitting and the inner diameter of the plastic tubing. Mechanical pressing is achieved by the use of press tool.

3.2.2 *press sleeve, n*—Cylindrical shaped stainless steel ring which is compressed with a pressing tool while located over the PEX tubing securing it permanently to the underlying insert fitting.

3.2.3 *press tool, n*—A device by which the stainless sleeve is compressed by a forming die that is radially closed down on the press sleeve by either hand powered or electro-mechanical pressing action.

4. Classification

4.1 This specification governs one class of fittings and stainless steel press sleeve suitable for use PEX tubing that meets either the requirements of Specifications **F876** or **F3253**, or with PE-RT tubing that meets the requirements of Specification **F2769**.

5. Materials and Manufacture

5.1 *Material*—Fittings shall be molded from sulfone plastic (SP) as specified in Classification **D6394**. The material shall be unreinforced polyphenylsulfone blends (group 03, Class 1, grade 2) or reworked plastic in accordance with 5.1.1.

5.1.1 *Rework Material*—Clean rework material of the same commercial designation, generated from the manufacturer’s own production may be used by the same manufacturer, provided the fittings meet all of the requirements of this specification. Reworked material shall not be introduced at a ratio exceeding 25 %.

TABLE 1 Polymer Insert Dimensions and Tolerances<sup>C</sup>

NTS	A <sup>A</sup>	±	B <sup>E</sup>	±	C <sup>D</sup>	D	±	E	±	F	H	r	±
	in.	in.	in.	in.	in.	in.	in.	in.	in.	in.	max in.	in.	in.
3/8	0.340	0.004	0.201	0.012	0° - 10°	0.307	0.012	0.344	0.008	15° - 25°	0.091	0.012	0.004
1/2	0.469	0.004	0.311	0.012	0° - 10°	0.437	0.012	0.344	0.008	15° - 25°	0.187	0.012	0.004
3/4	0.658	0.004	0.480	0.012	0° - 10°	0.626	0.012	0.344	0.008	15° - 25°	0.187	0.012	0.004
1	0.852	0.004	0.661	0.012	0° - 10°	0.823	0.012	0.472	0.008	N/A	N/A	0.051	0.004
1 1/4	1.034	0.004	0.807	0.012	0° - 10°	1.004	0.012	0.689	0.008	N/A	N/A	0.079	0.004
1 1/2	1.223	0.004	0.941	0.012	0° - 10°	1.193	0.012	0.689	0.008	N/A	N/A	0.079	0.004
2	1.579	0.004	1.244	0.012	0° - 10°	1.543	0.012	0.677	0.008	N/A	N/A	0.079	0.004

NTS	J	±	G	±	K	±	L	I	±	T <sup>B</sup>	R	±	X
	in.	in.	in.	in.	in.	in.	Min, in.	in.	in.	Min. in.	in.	in.	in.
3/8	0.110	0.008	0.087	0.008	0.378	0.016	0.512	0.043	0.008	0.047	0.008	0.004	35° - 45°
1/2	0.110	0.008	0.087	0.008	0.378	0.016	0.512	0.043	0.008	0.059	0.008	0.004	35° - 45°
3/4	0.110	0.008	0.087	0.008	0.378	0.016	0.512	0.043	0.008	0.067	0.008	0.004	35° - 45°
1	0.118	0.008	0.118	0.008	0.500	0.016	0.669	0.059	0.008	0.075	0.008	0.004	35° - 45°
1 1/4	0.126	0.008	0.165	0.008	0.720	0.016	0.906	0.083	0.008	0.091	0.008	0.004	35° - 45°
1 1/2	0.126	0.008	0.165	0.008	0.720	0.016	0.906	0.083	0.008	0.118	0.008	0.004	35° - 45°
2	0.126	0.008	0.165	0.008	0.720	0.016	0.906	0.083	0.008	0.142	0.008	0.004	35° - 45°

<sup>A</sup> Rib outside diameter shall be measured individually.

<sup>B</sup> Applies to entire fitting (not just to insert area), except for the area identified within the “H” dimension.

<sup>C</sup> Directional fittings shall be designed with sufficient overall dimensions to allow proper use of press tool without interference with previously completed press on the same fitting.

<sup>D</sup> Lead chamfer area is not considered a rib.

<sup>E</sup> ID “B” shall be maintained through the insert length “L”.

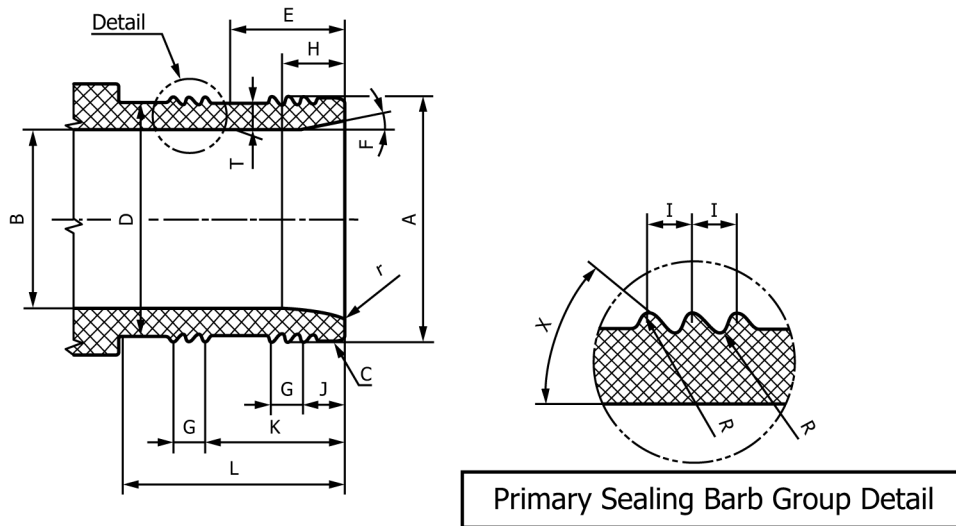

FIG. 1 Polymer Insert Dimensions

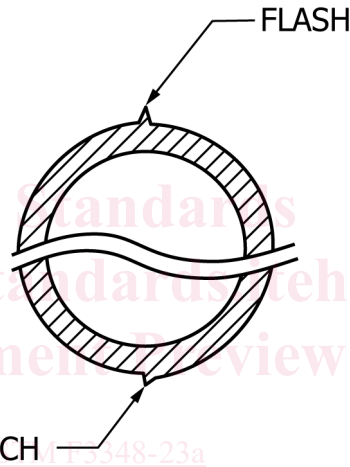

FIG. 1A Flash and Mismatch created by Imperfection in Die Half Interfaces<sup>F</sup>

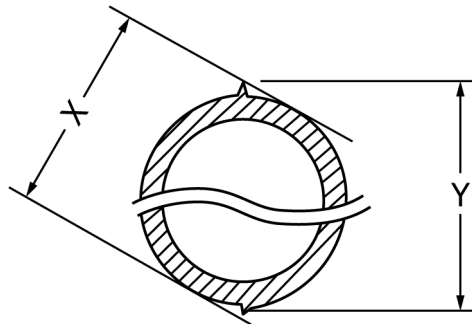
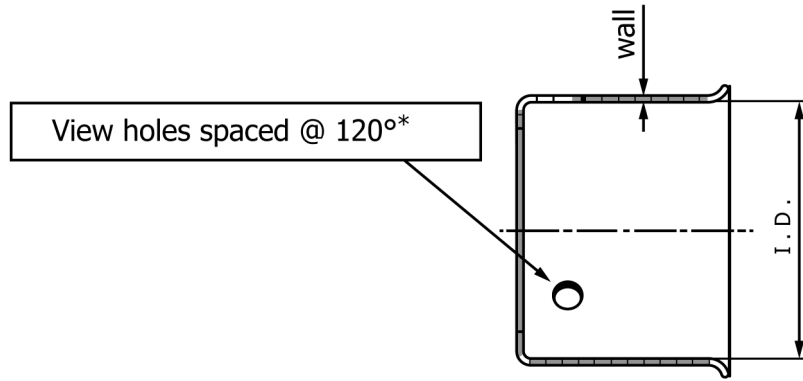

FIG. 1B Total Flash and Mismatch<sup>F</sup>

FIG. 1

<sup>F</sup> Fig.1A and Fig.1B are a graphic definition of flash and mismatch created by imperfection in die half interfaces. See 7.3. The total mismatch is assumed to be the difference between "X" and "Y." These dimensions may be measured with appropriate calipers or micrometers.



\*The three view holes' diameter and location per the fitting manufacturer's specifications.

FIG. 2 Un-Pressed Stainless Steel Sleeve Dimensions

TABLE 2 Press Sleeve Dimensions before Pressing<sup>A,B,C,D</sup>

NTS	ID	±	Wall	±
	in.	in.	in.	in.
3/8	0.512	0.006	0.023	0.003
1/2	0.636	0.006	0.023	0.003
3/4	0.892	0.006	0.023	0.003
1	1.140	0.006	0.023	0.003
1 1/4	1.386	0.006	0.031	0.003
1 1/2	1.636	0.006	0.031	0.003
2	2.138	0.006	0.031	0.003

<sup>A</sup> All dimensions shall be measured with appropriate micrometers, such as pin or ball micrometers for wall and outside diameter micrometers with flat anvils or vernier calipers shall be used to measure outside diameters and width of sleeves.

<sup>B</sup> The average measurement is obtained from measurements taken in at least two different circumferential positions which are equally spaced around the circumference.

<sup>C</sup> The average wall measurement is obtained from measurements taken in eight different positions which are equally spaced around the circumference.

<sup>D</sup> The maximum out-of-roundness of the press sleeve shall not inhibit assembly with the fitting and tubing. The press sleeve dimensions after pressing shall comply with Table 3.

5.2 *Press Sleeves*—Press sleeves shall be made from Specification A269/A269M UNS S30400 or S31600 stainless steel and have an allowable hardness of  $130 \pm 20$  HV5 according to Test Method E92.

5.3 *Potable Water Requirements*—Products intended for the transport of potable water shall be evaluated, tested and certified for conformance with NSF/ANSI Standard 61 or the health effects portion of NSF/ANSI Standard 14 by an acceptable certifying organization when required by the regulatory authority having jurisdiction.

NOTE 1—All wetted and pressure carrying polymeric materials used to manufacture the fittings should be suitable for the intended applications, that is, hot and cold potable water plumbing systems, in addition to the performance requirements of this specification. Those qualifying characteristics include but are not limited to an established hydrostatic design basis (HDB) in accordance with Test Method D2837 or a minimum required stress (MRS) in accordance with ISO 9080/ ISO 12162 and a demonstration of resistance to the long-term effects of those chemicals normally found in water conveyed in these applications (for example, disinfectants such as sodium hypochlorite used in potable water) at the maximum temperature stated in this specification.

6. Molded Part Properties

6.1 *Insert Crush*—The fitting insert shall not crack, split, or shatter when tested in accordance with 10.1.

6.2 *Splay*—The molded part shall be free of visible splay excepting some slight blushing at the gate location.

6.3 *Flash*—There shall be no measureable flash allowed.

6.4 *Mismatch*—Mismatch shall be limited to a maximum of 0.002 in.

7. Requirements

7.1 *General*—All performance tests shall be performed on assemblies of fittings, press sleeves, and PEX or PE-RT tubing. Fittings and press sleeves shall meet the material and dimensional requirements of this specification. PEX tubing shall meet the requirements of Specification F876 or F3253 and PE-RT tubing shall meet the requirements of Specification F2769. Use separate sets of assemblies for each performance test requirement.

7.2 Fittings manufactured according to this specification for use with PEX tubing shall comply with Specification F877 Requirements, Test Methods, and Retest and Rejection. Fittings manufactured according to this specification for use with PE-RT tubing shall comply with Specification F2769; Requirements, Test Methods, and Retest and Rejection

7.3 *Dimensions*—The dimensions and tolerances of fittings and press sleeves shall be in accordance with Table 1 and Fig. 1, Fig. 1A, and Fig. 1B and Table 2 and Fig. 2 when measured in accordance with 7.3.1. There shall be no measurable flash allowed. Mismatch shall be limited to a maximum of 0.002 in.

7.3.1 *Measurements*—Any randomly selected fitting or fittings, and press sleeve or press sleeves, shall be used to determine dimensions. Measurements shall be made in accordance with Test Method D2122, except when measuring diameters of the after pressed sleeves, which shall be measured perpendicular to the jaw closure plane as shown in Fig. 4 and shall be in accordance with Table 3.

7.3.2 *Directional Fitting Outlet(s) Angular Alignment*—The maximum angular variation of any molded outlet shall not exceed 1° off the true centerline axis of any adjacent outlet.

7.4 *Factory Assembled Press Sleeves*—Stainless steel press sleeves shall be assembled by the fitting manufacturer. Fitting design shall allow for either permanently attached (non-removable) press sleeves or snap-in-place (removable) press sleeves.