



Designation: A551/A551M – 08 (Reapproved 2023)

Standard Specification for Carbon Steel Tires for Railway and Rapid Transit Applications¹

This standard is issued under the fixed designation A551/A551M; the number immediately following the designation indicates the year of original adoption or, in the case of revision, the year of last revision. A number in parentheses indicates the year of last reapproval. A superscript epsilon (ϵ) indicates an editorial change since the last revision or reapproval.

1. Scope

1.1 This specification covers seven classes of carbon steel tires for railway and rapid transit use.

1.1.1 *Class A*—For untreated driving tires for locomotives in passenger service.

1.1.2 *Class AHT*—For heat-treated driving tires for locomotives in passenger service.

1.1.3 *Class B*—For untreated driving tires for freight locomotives and tires for locomotive-truck, tender-truck, trailer and car wheels, and miscellaneous service.

1.1.4 *Class BHT*—For heat-treated driving tires for freight locomotives and tires for trailer wheels.

1.1.5 *Class C*—For untreated tires for switching locomotives.

1.1.6 *Class CHT*—For heat-treated driving tires and switching locomotives and tires for locomotive-trucks, tender-trucks, trailer and car wheels, and miscellaneous service.

1.1.7 *Class DHT*—For heat-treated driving tires for locomotives with light braking conditions, heavily loaded trailer tires, and rapid transit wheels where off-tread brakes are employed.

1.2 Supplementary requirements, including those in the general requirements of Specification [A788/A788M](#), are provided for use when additional testing or inspection is desired. These shall apply only when specified individually by the purchaser in the order.

1.3 The values stated in either SI units or inch-pound units are to be regarded separately as standard. Within the text and tables the SI units are shown in brackets. The values stated in each system may not be exact equivalents; therefore each system shall be used independently of the other. Combining values from the two systems may result in nonconformance with the standard.

1.4 Unless the order specifies the applicable “M” specification designation, the tires shall be furnished to the inch-pound units.

¹ This specification is under the jurisdiction of ASTM Committee A01 on Steel, Stainless Steel and Related Alloys and is the direct responsibility of Subcommittee A01.06 on Steel Forgings and Billets.

Current edition approved March 15, 2023. Published April 2023. Originally approved in 1965 to replace Specifications A26 and A329. Last previous edition approved in 2018 as A551/A551M – 08 (2018). DOI: 10.1520/A0551_A0551M-08R23.

1.5 *This international standard was developed in accordance with internationally recognized principles on standardization established in the Decision on Principles for the Development of International Standards, Guides and Recommendations issued by the World Trade Organization Technical Barriers to Trade (TBT) Committee.*

2. Referenced Documents

2.1 *ASTM Standards*:²

[A370 Test Methods and Definitions for Mechanical Testing of Steel Products](#)

[A788/A788M Specification for Steel Forgings, General Requirements](#)

2.2 *AAR Standard*:³

[AAR M-107/M-208 Wheels, Carbon Steel](#)

3. Ordering Information and General Requirements

3.1 Material supplied to this specification shall conform to the requirements of Specification [A788/A788M](#), which outlines ordering information, manufacturing requirements, testing and retesting methods and procedures, marking, certification, product analysis variations, and additional supplementary requirements.

3.1.1 If the requirements of this specification are in conflict with those of Specification [A788/A788M](#), then the requirements of this specification shall prevail.

3.2 In addition to the ordering requirements from Specification [A788/A788M](#), the following details should be supplied:

3.2.1 Full identification of tread and flange contour with dimensional drawings as required,

3.2.2 Inside diameter to be rough machined or finished,

3.2.3 Intended service, and

3.2.4 Chemical composition requirements, if different from those given in [Table 1](#).

² For referenced ASTM standards, visit the ASTM website, www.astm.org, or contact ASTM Customer Service at service@astm.org. For *Annual Book of ASTM Standards* volume information, refer to the standard’s Document Summary page on the ASTM website.

³ Available from Association of American Railroads (AAR), 425 Third St., SW, Washington, DC 20024, <http://www.aar.org>.

TABLE 1 Chemical Requirements

Element wt %	Classes A and AHT	Classes B and BHT	Classes C, CHT, and DHT
Carbon	0.50–0.65	0.60–0.75	0.70–0.85
Manganese	0.60–0.90	0.60–0.90	0.60–0.90
Phosphorous, max	0.030	0.030	0.030
Sulfur	0.005–0.040	0.005–0.040	0.005–0.040
Silicon	0.15–1.00	0.15–1.00	0.15–1.00
Nickel, max ^A	0.25	0.25	0.25
Chromium, max ^A	0.25	0.25	0.25
Molybdenum, max ^A	0.10	0.10	0.10
Vanadium, max ^A	0.040	0.040	0.040
Copper, max	0.35	0.35	0.35
Aluminum, max	0.060	0.060	0.060
Titanium, max	0.03	0.03	0.03
Columbium, max (Niobium) ^B	0.05	0.05	0.05

^A The manufacturer may exceed the noted maximum limits for nickel, chromium, molybdenum, or vanadium provided that the following relationship (AAR M-107/M-208) is met:

$$930 - [570 \times \%C] - [80 \times \%Mn] - [20 \times \%Si] - [50 \times \%Cr] - [30 \times \%Ni] - [20 \times (\%Mo + \%V)] > 390$$

^B Columbium (Cb) and Niobium (Nb) are alternate names for Element 41 in the Periodic Table of the Elements.

4. Chemical Requirements

4.1 *Chemical Composition*—The steel shall conform to the requirements for chemical composition specified in Table 1, unless otherwise required by the purchaser (see 3.2.4).

4.1.1 The purchaser may use the product analysis provisions of Specification A788/A788M for tires produced to the requirements of Table 1. By agreement with the manufacturer, these provisions may be used also when the provisions of 3.2.4 apply.

5. Manufacture

5.1 *Discard*—Sufficient discard shall be made from each ingot to assure freedom from piping and undue segregation.

5.2 *Post Forge Cooling*—All tires, immediately after being rolled, shall be slow cooled in a manner to accomplish proper transformation without damage.

5.3 Heat Treatment:

5.3.1 Classes AHT, BHT, CHT, and DHT shall be heated to and held at the proper temperature for a sufficient time to effect the desired transformation and then shall be immersed in a suitable quenching medium.

5.3.2 Following quenching, the tires shall be charged into a furnace for tempering to meet the hardness requirements of 6.1.1, and then cooled under suitable conditions.

6. Hardness Requirement

6.1 Classes AHT, BHT, CHT, and DHT shall be accepted on the basis of a Brinell hardness test on the front face of 10 % of the tires from each heat at a location approximately 1 in. [25 mm] below the tread.

6.1.1 The tires shall conform to the following limits:

Class	AHT	BHT	CHT	DHT
Brinell hardness	223 to 277	255 to 302	285 to 331	321 to 363

6.1.2 Where continuous heat-treating furnaces are used, should any of the tested tires fail to meet the hardness requirements of 6.1.1, the manufacturer may offer for individual hardness measurements, all of the tires of that heat in the

lot for inspection. Those meeting the hardness requirements of 6.1.1 shall be accepted.

6.1.3 Where batch heat-treating furnaces are used, should any of the tires fail to meet the requirements of 6.1.1, the manufacturer may offer all of the tires in the heat treatment lot for individual hardness measurement. Those meeting the hardness requirements of 6.1.1 shall be accepted.

7. Reheat Treatment

7.1 The heat treatment of any tires failing to meet the specified hardness may be repeated in accordance with 5.3.1 and retested in accordance with Section 6.

8. Mating

8.1 The tires shall be grouped according to outside diameter and shipped in sets.

8.2 The variation in outside diameters in each set shall not exceed 1/16 in. [1.5 mm] for tires 33 in. [825 mm] or under in outside diameter, nor exceed 3/32 in. [2.5 mm] for tires over 33 in. [825 mm] in outside diameter.

9. Permissible Variations in Dimensions

9.1 Tires may be furnished with all surfaces as-rolled, and shall conform to the dimensions specified. When not specified, the following tolerances are acceptable:

9.1.1 *Height of Flange*—The flange height shall not be less, but may be 1/16 in. [1.5 mm] more, than that specified.

9.1.2 *Thickness of Flange*—The flange thickness shall not vary more than 1/16 in. [1.5 mm] from that specified.

9.1.3 *Radius of Throat*—The throat radius shall not vary more than 1/8 in. [3 mm] over, nor more than 1/16 in. [1.5 mm] under, that specified.

9.1.4 *Width of Tires*—The tire width may be 3/16 in. [4.8 mm] more than that specified.

9.1.5 *Inside Diameter*—For shrink fit tires, the rough inside diameter shall not be more, but may be 1/4 in. [6 mm] less, than that specified. When the finished inside diameter only is specified, the rough diameter shall be from 3/16 in. to 7/16 in. [5 mm to 11 mm] less than this diameter.

9.1.6 *Outside Diameter*—Unless otherwise specified for shrink fit tires, the outside diameter, when 54 in. [1350 mm] or under, shall not be less, but may be ½ in. [12.5 mm] more than that specified; and when over 54 in. [1350 mm], shall not vary more than ⅛ in. [3 mm] under, nor more than ⅜ in. [10 mm] over that specified.

9.1.7 *Roundness*—Tires shall not be out-of-round more than ⅓ in. [1.5 mm] for tires 33 in. [825 mm] or under in outside diameter, nor more than ⅜ in. [2.5 mm] for tires over 33 in. [825 mm] in outside diameter.

10. Marking

10.1 In addition to the marking requirements of Specification A788/A788M, the name of the manufacturer or brand, the serial number, heat number, date of manufacture, and class shall be legibly stamped on each tire close to the inside edge where they will not be removed by the last turning.

11. Keywords

11.1 forged wheel tires; locomotive tires; rail applications; rail car tires

SUPPLEMENTARY REQUIREMENTS

S1. Incidental Alloying Elements

S1.1 Incidental elements for the grades specified in Table 1 shall not exceed the limits shown in Table S1.1.

S1.2 The values determined for the elements listed in Table S1.1 shall be reported with the heat analysis.

S2. Classes AHT, BHT, CHT, and DHT

S2.1 In addition to hardness testing, one tension test shall be made from one tire per heat, per heat treatment charge.

S2.2 The tension test, done in accordance with Test Methods and Definitions A370, shall conform to the requirements of Table S2.1.

S2.3 The tension test specimen shall be taken from the position indicated in Fig. S2.1.

TABLE S1.1 Incidental Alloying Elements

Element	Composition, max, %
Chromium	0.15
Nickel	0.25
Molybdenum	0.06

TABLE S2.1 Tension Tests

Class	Tensile Strength, min		Elongation in 2 in. or 50 mm, min, %	Reduction of Area, min, %
	ksi	MPa		
AHT	110	760	16.0	32.0
BHT	125	860	14.0	28.0
CHT	140	965	12.0	24.0
DHT	155	1070	10.0	20.0

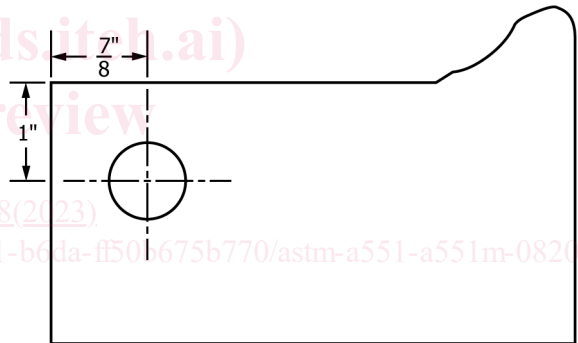

FIG. S2.1 Location in Tire of Tension Test Specimen