



# Standard Test Method for Measuring Softball and Baseball Bat Performance Factor<sup>1</sup>

This standard is issued under the fixed designation F1890; the number immediately following the designation indicates the year of original adoption or, in the case of revision, the year of last revision. A number in parentheses indicates the year of last reapproval. A superscript epsilon ( $\epsilon$ ) indicates an editorial change since the last revision or reapproval.

## 1. Scope

1.1 A method for determining bat performance by measuring the bat-ball coefficient of restitution (BBCOR) and deriving the bat performance factor (BPF). It is applicable to softball and baseball bats of any construction or material. The method provides a quantitative measure of bat dynamic performance that may be used for comparison purposes.

1.2 The BBCOR and BPF are calculated from measurements taken in the laboratory on test equipment meeting the requirements defined in this method.

1.3 Bat performance is found in this standard assuming the bat is pivoted.

1.4 The values stated in inch-pound units are to be regarded as standard. The values given in parentheses are units that are provided for information only and are not considered standard.

1.5 *This standard does not purport to address all of the safety concerns, if any, associated with its use. It is the responsibility of the user of this standard to establish appropriate safety, health, and environmental practices and determine the applicability of regulatory limitations prior to use.*

1.6 *This international standard was developed in accordance with internationally recognized principles on standardization established in the Decision on Principles for the Development of International Standards, Guides and Recommendations issued by the World Trade Organization Technical Barriers to Trade (TBT) Committee.*

## 2. Referenced Documents

2.1 *ASTM Standards:*<sup>2</sup>

**F1887** Test Method for Measuring the Coefficient of Restitution (COR) of Baseballs and Softballs

**F1888** Test Method for Compression-Displacement of Baseballs and Softballs

**F2398** Test Method for Measuring Moment of Inertia and Center of Percussion of a Baseball or Softball Bat

## 3. Terminology

3.1 *Definitions of Terms Specific to This Standard:*

3.1.1 *balance point (BP), n*—distance to the center of mass of a bat when measured from the knob end of the bat.

<sup>1</sup> This test method is under the jurisdiction of ASTM Committee F08 on Sports Equipment, Playing Surfaces, and Facilities and is the direct responsibility of Subcommittee F08.26 on Baseball and Softball Equipment.

Current edition approved Sept. 1, 2022/April 1, 2023. Published October 2022/April 2023. Originally approved in 1998. Last previous edition approved in 2017/2022 as F1890 – 17 (2022).<sup>1</sup> DOI: [10.1520/F1890-17R22-10.1520/F1890-23](https://doi.org/10.1520/F1890-17R22-10.1520/F1890-23).

<sup>2</sup> For referenced ASTM standards, visit the ASTM website, [www.astm.org](http://www.astm.org), or contact ASTM Customer Service at [service@astm.org](mailto:service@astm.org). For *Annual Book of ASTM Standards* volume information, refer to the standard's Document Summary page on the ASTM website.

3.1.2 *coefficient of restitution (COR)*, *n*—the relative speed of the objects after impact divided by the relative speed of the objects before impact.

3.1.3 *bat-ball coefficient of restitution (BBCOR)*, *n*—COR of a specific ball colliding with a bat as defined in this test method.

3.1.4 *bat performance factor (BPF)*, *n*—ratio of BBCOR to ball COR as defined in this test method.

3.1.5 *center of percussion (COP)*, *n*—impact location on the bat that produces no reaction force at the pivot point and causes the bat to rotate about the pivot point, taken 6 in. (152 mm) from the knob end of the bat.

3.1.6 *moment of inertia (MOI)*, *n*—measure of mass distribution relative to a pivot point, taken 6 in. (152 mm) from the knob end of the bat.

#### 4. Significance and Use

4.1 These test methods offer a laboratory means to quantitatively compare the performance of softball and baseball bats.

#### 5. Apparatus

5.1 *Test Balls*—Softballs or baseballs as determined by those specifying the bat test requirements and tested in accordance with the following procedures. Perform ball compression test of Test Method **F1888** prior to ball COR test of Test Method **F1887**.

##### 5.1.1 *Softballs:*

5.1.1.1 *Compression*—350 to 375 lb (1557 to 1688 N) (Test Method **F1888**.)

5.1.1.2 *Weight*—6.25 to 6.75 oz (177.2 to 191.4 g).

5.1.1.3 *Size*—12.00 to 12.25-in. (304.8 to 311.1-mm) circumference (Test Method **F1888**).

5.1.1.4 *Ball COR*—0.465 to 0.475 (Test Method **F1887**).

##### 5.1.2 *Baseballs:*

5.1.2.1 *Compression*—175 to 200 lb (778 to 890 N) (Test Method **F1888** using 0.20 in. (5.08 mm) deflection).

5.1.2.2 *Weight*—5.00 to 5.25 oz (141.8 to 148.8 g).

5.1.2.3 *Size*—9.00 to 9.50 in. (228.6 to 241.3 mm) circumference (Test Method **F1888**).

5.1.2.4 *Ball COR*—0.545 to 0.555 (Test Method **F1887**).

##### 5.2 *Bat-Ball COR Test Apparatus:*

5.2.1 *Ball Cannon*—A device capable of shooting a ball at a speed of at least 88 ft/s (26.8 m/s). The ball shall not have a spin rate in excess of 10 rpm. Typical pitching machines cannot yield the aiming accuracy required by this test method. Cannon exhaust air must not cause motion of the bat in the absence of an impact. The ball cannon can be any distance from impact location, as long as it can meet the ball aim requirements and provide six valid impacts in twelve shots or less.

5.2.2 *Bat Speed Gate*—A light-trap device, or an equivalent, capable of measuring an edge traveling at speeds of between 5 and 15 ft/s with a resolution of 0.01 ft/s (0.003 m/s) and an accuracy of at least  $\pm 1\%$ . The first sensor shall trigger after the bat rotates between 5 to 10° from its start position. The second sensor shall trigger 30 to 35° after the first sensor. Reference **Fig. 1**.

5.2.2.1 *Optional Bat Speed Sensor*—Device to measure bat rotational speed for at least 100° after impact. Device shall read speeds up to 3000°/s with an accuracy of at least 1°/s (found to be achievable using an optical encoder). Bat speed is taken from the slope of the linear least-squares fit to the bat rotation angle versus time data between 5 and 95° after impact.

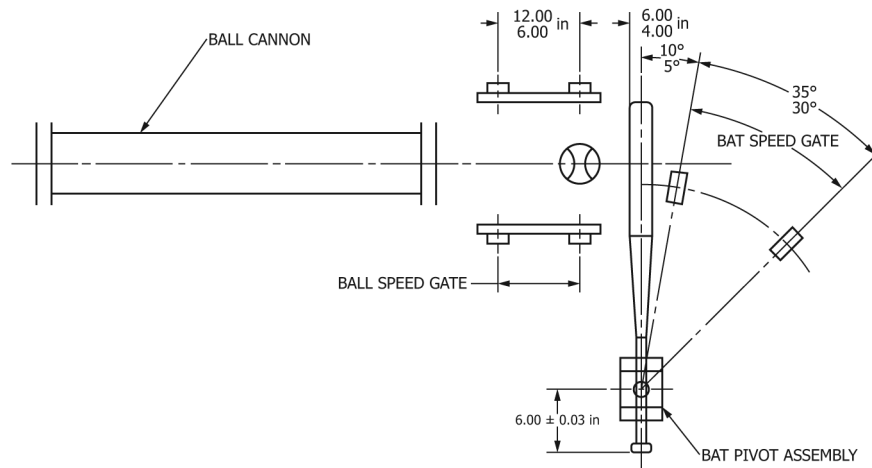

FIG. 1 Bat Testing Machine

5.2.3 *Ball Speed Gate*—A light-trap device, or an equivalent, capable of measuring a sphere traveling at speeds in excess of 88 ft/s (26.8 m/s) with an accuracy of 0.5 ft/s (0.2 m/s) or better. The device shall measure across a length of no less than half the ball diameter to avoid centering error. The distance between the two sensors shall be determined to within  $\pm 0.03$  in. ( $\pm 0.76$  mm) and must be between 6 and 12 in. (152 and 305 mm). Prior to impact, the sensor closest to the bat must be between 4 and 6 in. (102 and 152 mm) from the bat. Reference Fig. 1.

5.2.4 *Bat Pivot Support*—A turntable, rotating in the horizontal plane, with clamps to support and align the bat in the path of the ball. The clamp surfaces shall be a 45° v-clamp with a radius no greater than 2.0 in. (50.8 mm). The rotating clamp and shaft assembly shall not weigh more than 6 lb (2.7 kg) and shall spin freely via ball bearings (see Fig. 1). The polar MOI for the clamp turntable assembly shall not exceed 300 oz-in.<sup>2</sup> (5498 kg-mm<sup>2</sup>).

6. Calibration and Standardization

6.1 *Ball Speed Gate*—The distances between the sensors of the speed gates must be measured and recorded to the stated tolerances. The accuracy of the timers used in the velocity sensors must be adequate to provide the stated velocity accuracy at maximum stated speeds. The timers used shall be calibrated on at least a yearly basis.

6.2 *Reference Standards and Blanks*—A standard bat and ball shall be used for reference purposes to verify proper machine operation.

6.3 Calibration:

6.3.1 Determine the balance point (BP), MOI, and COP of a large calibration mass (MOI  $\geq 30\,000$  oz-in.<sup>2</sup> (549 000 kg-mm<sup>2</sup>)) in accordance with Test Method F2398.

6.3.2 Mount the large calibration mass in the bat pivot support clamps per 8.2.4.

6.3.3 Select a test ball in accordance with 5.1 as determined by those specifying the bat test, and record the actual values of compression, weight, size, and COR of the ball in accordance with 5.1.

6.3.4 Shoot the ball at the calibration mass COP, observing the necessary safety precautions and in accordance with Section 8 except as noted.

6.3.5 Determine  $K_{\text{calibration}}$  as follows:

$$K_{\text{calibration}} = \frac{1 + \text{BallCOR}}{\left(1 + \frac{I + I_p}{mR^2}\right) \left(\frac{t}{d}\right) \left(\frac{D}{T}\right) \left(\frac{R}{r}\right)} = \frac{1 + \text{BallCOR}}{\left(1 + \frac{I + I_p}{mR^2}\right) \left(\frac{V_{\text{bat}}}{v_i}\right)} \tag{1}$$

where:

*Ball COR* = ball COR (Test Method **F1887**) of the ball used in each impact,  
*I* = moment of inertia (MOI) of mass, Test Method **F2398**, oz-in.<sup>2</sup> (kg-m<sup>2</sup>),  
*I<sub>p</sub>* = moment of inertia (MOI) of bat pivot, oz-in.<sup>2</sup> (kg-m<sup>2</sup>),  
*R* = COP distance, Test Method **F2398**, in. (m),  
*r* = radius to bat speed sensors, in. (m),  
*T* = time for bat to travel through bat speed sensors, s,  
*t* = time for ball to travel through ball speed sensors, s,  
*D* = distance between bat speed sensors, in. (m),  
*d* = distance between ball speed sensors, in. (m),  
*v<sub>i</sub>* = ball inbound speed, in./s (m/s),  
*V<sub>bat</sub>* = bat recoiling speed at the impact location, in./s (m/s), and  
*m* = weight of the test ball used in each impact, oz (g).

6.3.6 Calculate the average  $K_{\text{calibration}}$  for the calibration mass from six valid impacts.

6.3.7 The average  $K_{\text{calibration}}$  must fall between 0.98 and 1.02. If average  $K_{\text{calibration}}$  is out of range, check ball and bat speed gates, Ball COR, *I*, *R*, *m*, *I<sub>pivot</sub>*.

## 7. Conditioning

### 7.1 Ball and Bat Conditioning and Test Room Conditions:

7.1.1 Test balls shall be placed in an environmentally controlled space for at least 14 days immediately before testing. Wood bats shall be stored at these environmental conditions for at least 24 h prior to testing. Non-wood bats shall be stored at these environmental conditions for at least 2 h prior to testing.

7.1.2 Temperature is to be maintained at  $72 \pm 4^{\circ}\text{F}$  ( $22 \pm 2^{\circ}\text{C}$ ).

7.1.3 Relative humidity is to be maintained between 40 and 60 %.

7.1.4 Temperature and relative humidity are to be measured and recorded hourly within  $\pm 0.5^{\circ}\text{F}$  ( $\pm 0.3^{\circ}\text{C}$ ) and  $\pm 2\%$  RH over conditioning and test duration.

## 8. Procedure

8.1 *Determination of Bat Features and Test Location*—Determine bat balance point (BP), bat MOI, and bat COP in accordance with Test Method **F2398**.

### 8.2 Bat Test Procedure:

8.2.1 Ready and calibrate ball and bat speed gates in accordance with the manufacturer's instructions.

8.2.2 Select a test ball in accordance with **5.1**, and record the actual values of compression, weight, size, and COR of the ball in accordance with **5.1**.

8.2.3 Set ball cannon to fire the ball at the desired impact speed of 88 ft/s (26.8 m/s). Valid test speeds are considered to be those within  $\pm 1\%$  of the targeted test speed.

8.2.4 Mount bat in the clamps on the bat pivot support. The knob end of the bat must be  $6 \pm 0.03$  in. ( $152.4 \pm 0.76$  mm) from the axis of rotation of the turntable assembly. Impact location(s) to be determined by those specifying the test requirements.

8.2.5 The ball impact must be centered vertically and horizontally on the bat at the desired impact location.

8.2.6 Locate the bat against the start position reference to obtain a ball rebound parallel to the inbound ball line of travel. (See **Fig. 1**.)

8.2.7 Verify that all speed sensors are reset and ready to take data.

8.2.8 Orient the test ball in ball cannon so that its impact with the bat will occur between the stitches of the ball.

8.2.9 Shoot the ball at the bat, observing the necessary safety precautions.

8.2.10 Record ball inbound speed and bat rebound speed.

8.2.10.1 *Optional*—Record ball rebound speed. The ball rebound angle immediately after impact should be within  $\pm 10^\circ$  of the inbound ball path.

8.2.11 Six valid impact readings are required per impact location. For a given test ball, rotate the ball in the cannon between impacts so that the impact area of the ball is different for each impact.

8.2.11.1 If identifying maximum performance is desired, the performance at the peak location should be at least 0.5 % greater than the performance at the adjacent bat axial locations.

## 9. Calculation of Results

9.1 Calculate the BBCOR for each valid impact using Eq 2:

$$BBCOR_{batout} = \left(1 + \frac{M_e}{m}\right) \left(\frac{t}{d}\right) \left(\frac{D}{T}\right) \left(\frac{Q}{r}\right) - 1 \quad (2)$$

where:

$$M_e = \frac{I + I_p}{Q^2} \quad (3)$$

and:

$M_e$  = effective mass of a pivoted bat, oz (g),

$I$  = moment of inertia (MOI) of bat, Test Method F2398, oz-in.<sup>2</sup> (kg-m<sup>2</sup>),

$I_p$  = moment of inertia (MOI) of bat pivot, oz-in.<sup>2</sup> (kg-m<sup>2</sup>), and

$Q$  = distance from the impact location to the pivot point location, in. (m).

9.2 Calculate the BPF for each valid impact using Eq 4:

$$BPF_{batout} = \frac{BBCOR_{batout}}{Ball\ COR} \quad (4)$$

9.3 Calculate the average BPF for the test bat from the six valid impacts as follows:

9.3.1 For baseball bats, calculate the average BPF using Eq 5.

$$BPF_{batout(avg)} = \frac{((BPF_{batout})_1 + (BPF_{batout})_2 + \dots + (BPF_{batout})_6)}{6} \quad (5)$$

9.3.2 For softball bats, calculate the average BPF using Eq 6.

$$BPF_{batout(avg)} = \frac{((BPF_{batout})_1 + (BPF_{batout})_2 + \dots + (BPF_{batout})_6)}{6} - 0.05 \quad (6)$$

## 10. Report

10.1 Report the following information:

10.1.1 Name of the test facility and test operator,