



SLOVENSKI STANDARD
SIST EN 14231:2003
01-november-2003

Preskušanje naravnega kamna – Ugotavljanje odpornosti proti zdrsu – metoda z nihalom

Natural stone test methods - Determination of the slip resistance by means of the pendulum tester

Prüfverfahren für Naturstein - Bestimmung des Gleitwiderstandes mit Hilfe des Pendelprüfgerätes

Méthodes d'essai pour les pierres naturelles - Détermination de la résistance a la glissance au moyen du pendule de frottement

iTeh STANDARD PREVIEW
(standards.iteh.ai)
<https://standards.iteh.ai/catalog/standards/sist/b4ec918b-06ed-43ea-a289-c57b4a341ea2/sist-en-14231-2003>

Ta slovenski standard je istoveten z: EN 14231:2003

ICS:

73.020	Rudarstvo in kamnolomsko izkopavanje	Mining and quarrying
91.100.15	Mineralni materiali in izdelki	Mineral materials and products

SIST EN 14231:2003

en

iTeh STANDARD PREVIEW
(standards.iteh.ai)

SIST EN 14231:2003

<https://standards.iteh.ai/catalog/standards/sist/b4ec918b-06ed-43ea-a289-c57b4a341ea2/sist-en-14231-2003>

EUROPEAN STANDARD
NORME EUROPÉENNE
EUROPÄISCHE NORM

EN 14231

April 2003

ICS 73.020; 91.100.15

English version

Natural stone test methods - Determination of the slip resistance by means of the pendulum tester

Méthodes d'essai pour les pierres naturelles -
Détermination de la résistance à la glissance au moyen du
pendule de frottement

Prüfverfahren für Naturstein - Bestimmung des
Gleitwiderstandes mit Hilfe des Pendelprüfgerätes

This European Standard was approved by CEN on 26 May 2002.

CEN members are bound to comply with the CEN/CENELEC Internal Regulations which stipulate the conditions for giving this European Standard the status of a national standard without any alteration. Up-to-date lists and bibliographical references concerning such national standards may be obtained on application to the Management Centre or to any CEN member.

This European Standard exists in three official versions (English, French, German). A version in any other language made by translation under the responsibility of a CEN member into its own language and notified to the Management Centre has the same status as the official versions.

CEN members are the national standards bodies of Austria, Belgium, Czech Republic, Denmark, Finland, France, Germany, Greece, Hungary, Iceland, Ireland, Italy, Luxembourg, Malta, Netherlands, Norway, Portugal, Slovakia, Spain, Sweden, Switzerland and United Kingdom.

[SIST EN 14231:2003](https://standards.iteh.ai/catalog/standards/sist/b4ec918b-06ed-43ea-a289-c57b4a341ea2/sist-en-14231-2003)

<https://standards.iteh.ai/catalog/standards/sist/b4ec918b-06ed-43ea-a289-c57b4a341ea2/sist-en-14231-2003>



EUROPEAN COMMITTEE FOR STANDARDIZATION
COMITÉ EUROPÉEN DE NORMALISATION
EUROPÄISCHES KOMITEE FÜR NORMUNG

Management Centre: rue de Stassart, 36 B-1050 Brussels

Contents

	page
Foreword	3
1 Scope	5
2 Normative references	5
3 Principle	5
4 Terms and definitions	5
5 Apparatus	6
6 Materials	9
7 Preparation of the specimens	9
7.1 Sampling	9
7.2 Dimensions of the test specimens	9
8 Test procedure	10
8.1 General	10
8.2 Test procedure (in dry conditions)	10
8.3 Test procedure (in wet conditions)	10
9 Expression of results	11
10 Test report	11
Annex A (normative) Calibration of the pendulum friction tester	13
A.1 Weighing of components	13
A.2 Balancing of the pendulum arm assembly	13
A.3 Setting the effective spring tension	13
A.4 Setting the pointer stop	13

Foreword

This document (EN 14231:2003) has been prepared by Technical Committee CEN/TC 246, "Natural stones", the secretariat of which is held by UNI.

This European Standard shall be given the status of a national standard, either by publication of an identical text or by endorsement, at the latest by October 2003, and conflicting national standards shall be withdrawn at the latest by October 2003.

This draft standard is one of the series of draft standards for tests on natural stone.

Test methods for natural stone consist of the following:

EN 1925, *Natural stone test methods - Determination of water absorption coefficient by capillarity*

EN 1926, *Natural stone test methods - Determination of compressive strength*

EN 1936, *Natural stone test methods - Determination of real density and apparent density and of total and open porosity*

EN 12370, *Natural stone test methods - Determination of resistance to crystallisation (by total immersion)*

EN 12371, *Natural stone test methods - Determination of frost resistance*

EN 12372, *Natural stone test methods - Determination of flexural strength under concentrated load*

EN 12407, *Natural stone test methods - Petrographic description*

EN 13161, *Natural stone test methods - Determination of flexural strength under constant moment*

EN 13364, *Natural stone test methods - Determination of the breaking load at dowel hole*

EN 13755, *Natural stone test methods - Determination of water absorption at atmospheric pressure*

EN 13919, *Natural stone test methods - Determination of resistance to ageing by SO₂ action in the presence of humidity*

prEN 13373, *Natural stone test methods - Determination of geometric characteristics*

prEN 14066, *Natural stones test methods - Determination of resistance to ageing by thermal shock*

prEN 14147, *Natural stone test methods - Determination of resistance to ageing by salt mist*

prEN 14157, *Natural stone test methods - Determination of the abrasion resistance*

prEN 14158, *Natural stone test methods - Determination of rupture energy*

prEN 14205, *Natural stone test methods - Determination of Knoop hardness*

prEN 14231, *Natural stone test methods - Determination of the slip resistance by means of the pendulum tester*

prEN 14579, *Natural stone test methods - Determination of sound speed propagation*

prEN 14580, *Natural stone test methods - Determination of static elastic modulus*

EN 14231:2003 (E)

prEN 14581, *Natural stone test methods - Determination of thermal expansion coefficient*

No existing European Standard is superseded.

This European Standard has an Annex A (normative).

According to the CEN/CENELEC Internal Regulations, the national standards organizations of the following countries are bound to implement this European Standard: Austria, Belgium, Czech Republic, Denmark, Finland, France, Germany, Greece, Hungary, Iceland, Ireland, Italy, Luxembourg, Malta, Netherlands, Norway, Portugal, Slovakia, Spain, Sweden, Switzerland and the United Kingdom.

iTeh STANDARD PREVIEW
(standards.iteh.ai)

[SIST EN 14231:2003](#)

<https://standards.iteh.ai/catalog/standards/sist/b4ec918b-06ed-43ea-a289-c57b4a341ea2/sist-en-14231-2003>

1 Scope

This European Standard specifies a test method to determine the slip resistance value of the surface of the exposed face of natural stone elements intended to be used for flooring in buildings.

NOTE 1 If the surface of the exposed face has a roughness measured according to prEN 13373 higher than 1 mm it will be considered as not slippery, without performing the test.

NOTE 2 This method may be used for laboratory measurements or on floors in service.

2 Normative references

This European Standard incorporates by dated or undated reference, provisions from other publications. These normative references are cited at the appropriate places in the text and the publications are listed hereafter. For dated references, subsequent amendments to or revisions of any of these publications apply to this European Standard only when incorporated in it by amendment or revision. For undated references the latest edition of the publication referred to applies.

ISO 48, *Rubber, vulcanized or thermoplastics – Determination of hardness (hardness between 10 IRHD and 100 IRHD)*

ISO 4662, *Rubber – Determination of rebound resilience of vulcanizates*

ISO 7619, *Rubber – Determination of indentation hardness by means of pocket hardness meters*

[SIST EN 14231:2003](https://standards.iteh.ai/catalog/standards/sist/b4ec918b-06ed-43ea-a289-c57b4a341ea2/sist-en-14231-2003)

<https://standards.iteh.ai/catalog/standards/sist/b4ec918b-06ed-43ea-a289-c57b4a341ea2/sist-en-14231-2003>

3 Principle

The pendulum friction tester incorporates a spring loaded slider made of a standard rubber attached to the end of the pendulum. On swinging the pendulum the frictional force between slider and test surface is measured by the reduction in length of the swing using a calibrated scale.

4 Terms and definitions

For the purposes of this European Standard, the following terms and definitions apply:

4.1

slip resistance

is the property of the floor surface to maintain the adhesion of pedestrian footwear.

NOTE Loss of adhesion leads to loss of control by the pedestrian with consequent increase in the risk of falling.

4.2

friction

is the resistance to relative motion between two bodies in contact, in this case the slider and the test specimen or the footwear sole and the trafficked surface. The frictional force is the force acting tangentially in the contact area.

4.3

slip resistance value (SRV)

the pendulum friction tester incorporates a slider manufactured of rubber. It measures the friction between the slider and the test surface and provides a standardised value of the slip resistance. This is called the slip resistance value (SRV) and shall be measured both in dry and wet conditions.

EN 14231:2003 (E)

5 Apparatus

5.1 The pendulum friction tester shall be manufactured as shown in Figure 1. All bearings and working parts shall be enclosed as far as possible, and all materials used shall be treated to prevent corrosion under wet conditions.

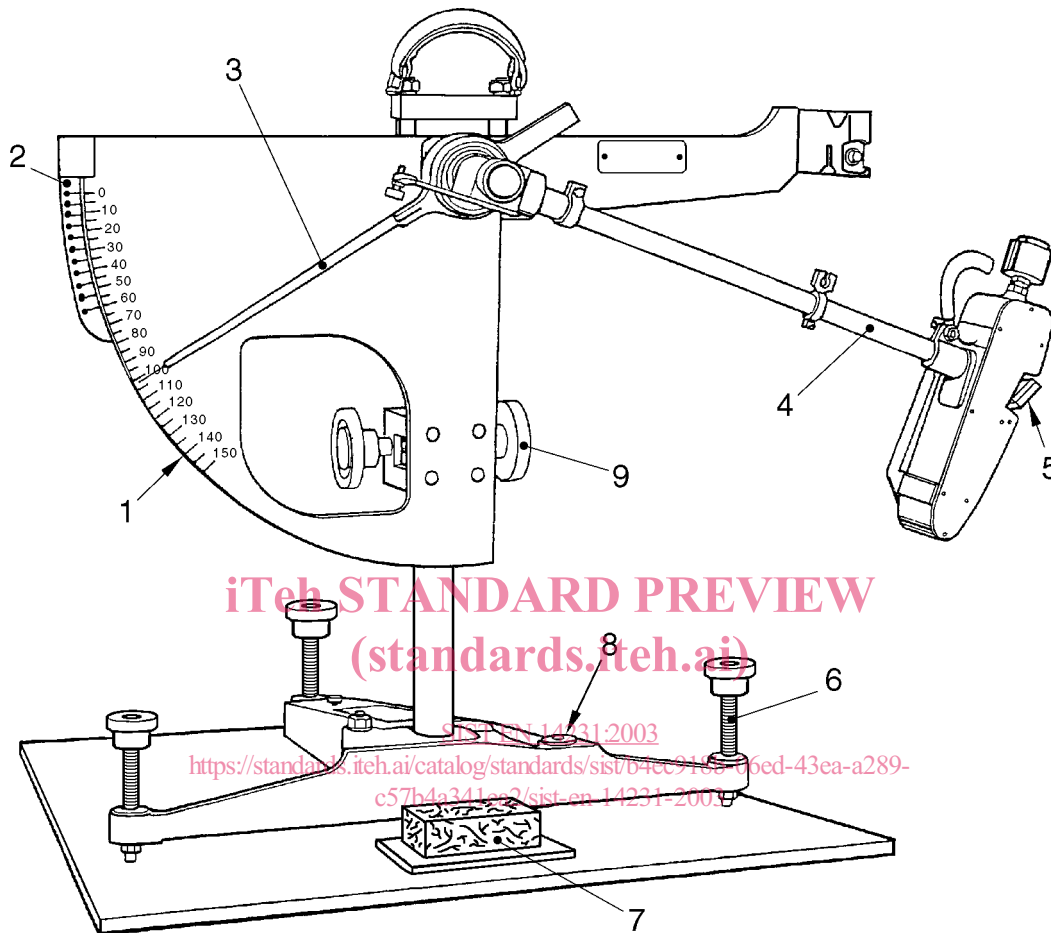

- 1 C scale (126 mm sliding length)
- 2 F scale (76 mm sliding length)
- 3 Pointer
- 4 Pendulum
- 5 Rubber slider
- 6 Levelling screw
- 7 Spirit level
- 8 Vertical adjustment screw
- 9 Test specimen holder

Figure 1 — Pendulum friction tester

5.2 The pendulum friction tester shall have the following features:

- 1) A spring loaded rubber coated slider as specified in clauses 5.4 to 5.10. It shall be mounted on the end of a pendulum arm so that the sliding edge is (510 ± 1) mm from the axis of suspension.
- 2) Means of setting the support column of equipment vertical.
- 3) A base of sufficient mass to ensure that the equipment remains stable during the test.
- 4) Means of raising and lowering the axis of suspension of the pendulum arm so that the slider can:
 - i) swing clear of the surface of the specimen; and
 - ii) be set to traverse a surface over a fixed length of (126 ± 1) mm when using the wide slider or (76 ± 1) mm when using the narrow slider. Gauges with these distances marked are required as shown in Figure 2.

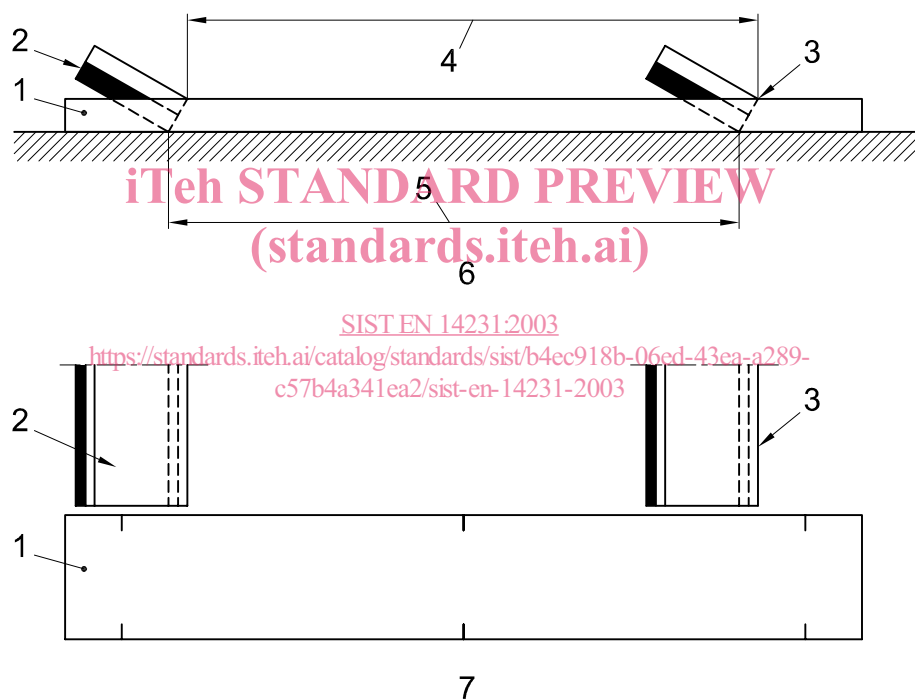

- 1 Gauge
- 2 Slider
- 3 Reference edge
- 4 Sliding length measured
- 5 Actual sliding length
- 6 Side view
- 7 Plan view

Figure 2 — Sliding length gauge

5) Means of holding and releasing the pendulum arm so that it falls freely from a horizontal position.

6) A pointer of nominal length of 300 mm, balanced about the axis of suspension, indicating the position of the pendulum arm throughout its forward swing and moving over the circular scale. The mass of the pointer shall be not more than 85 g.

7) The friction in the pointer mechanism shall be adjustable so that, with the pendulum arm swinging freely from a horizontal position, the outward tip of the pointer may be brought to rest on the forward swing of the arm at a point (10 ± 1) mm below the horizontal. This is the 0 reading.