



Standard Test Methods for Measuring High-Speed Bat Performance¹

This standard is issued under the fixed designation F2219; the number immediately following the designation indicates the year of original adoption or, in the case of revision, the year of last revision. A number in parentheses indicates the year of last reapproval. A superscript epsilon (ϵ) indicates an editorial change since the last revision or reapproval.

1. Scope

1.1 A method for determining bat performance by measuring the bat-ball coefficient of restitution (BBCOR), deriving the collision efficiency (e_a), and calculating a batted-ball speed (BBS). It is applicable to baseball and softball bats of any construction or material. The test methods provide quantitative measures of bat dynamic performance that may be used for comparison purposes.

1.2 The BBCOR and BBS are each calculated from measurements taken in the laboratory on test equipment meeting the requirements defined in this standard.

1.3 Bat performance is found in this standard assuming the bat is unconstrained.

1.4 The values stated in inch-pound units are to be regarded as standard. The values given in parentheses are mathematical conversions to SI units that are provided for information only and are not considered standard.

1.5 *This standard does not purport to address all of the safety concerns, if any, associated with its use. It is the responsibility of the user of this standard to establish appropriate safety, health, and environmental practices and determine the applicability of regulatory limitations prior to use.*

1.6 *This international standard was developed in accordance with internationally recognized principles on standardization established in the Decision on Principles for the Development of International Standards, Guides and Recommendations issued by the World Trade Organization Technical Barriers to Trade (TBT) Committee.*

2. Referenced Documents

2.1 ASTM Standards:²

F1887 Test Method for Measuring the Coefficient of Restitution (COR) of Baseballs and Softballs

¹ These test methods are under the jurisdiction of ASTM Committee F08 on Sports Equipment, Playing Surfaces, and Facilities and are the direct responsibility of Subcommittee F08.26 on Baseball and Softball Equipment.

Current edition approved April 1, 2023. Published April 2023. Originally approved in 2002. Last previous edition approved in 2022 as F2219 – 14 (2022). DOI: 10.1520/F2219-23.

² For referenced ASTM standards, visit the ASTM website, www.astm.org, or contact ASTM Customer Service at service@astm.org. For *Annual Book of ASTM Standards* volume information, refer to the standard's Document Summary page on the ASTM website.

F1888 Test Method for Compression-Displacement of Baseballs and Softballs

F2398 Test Method for Measuring Moment of Inertia and Center of Percussion of a Baseball or Softball Bat

F2845 Test Method for Measuring the Dynamic Stiffness (DS) and Cylindrical Coefficient of Restitution (CCOR) of Baseballs and Softballs

3. Terminology

3.1 Definitions of Terms Specific to This Standard:

3.1.1 *balance point (BP), n*—distance to the center of mass from the knob end of the bat.

3.1.2 *bat-ball coefficient of restitution (BBCOR), n*—COR of a specific ball colliding with a bat.

3.1.3 *batted ball speed (BBS), n*—the speed that a ball would be hit off a bat in play based on given pitch and bat speeds.

3.1.4 *coefficient of restitution (COR), n*—measure of impact efficiency calculated as the relative speed of the objects after impact divided by the relative speed of the objects before impact.

3.1.5 *collision efficiency (e_a), n*—ratio of ball exit speed to the ball inbound speed.

3.1.6 *cylindrical coefficient of restitution (CCOR), n*—the ratio of the rebound to incoming speed of a ball impacting a solid rigid cylinder.

3.1.7 *dynamic stiffness (DS), n*—a normalized measure of the ball impact force having units of stiffness (lb/in. or kN/m). It is obtained by dividing the square of the peak force between the ball and impact surface by the ball mass and the square of the incoming ball speed.

3.1.8 *moment of inertia (MOI), n*—measure of mass distribution relative to an axis of rotation. It is the product of the mass multiplied by the square of the distance to the mass, summed over the entire bat.

3.1.9 *test sponsor, n*—group, association or individual specifying test requirements including ball specifications, performance measure, and test speed.

4. Significance and Use

4.1 These test methods offer a laboratory means to quantitatively compare the performance of baseball and softball bats.

4.2 Use of these test methods can provide quantitative metrics of bat performance.

5. Apparatus and Equipment

5.1 *Test Balls*—Baseballs or softballs as determined by the test sponsor.

5.1.1 Ball specification values are to be recorded and traced to individual balls.

5.2 *Bat-Ball Test Apparatus:*

5.2.1 *Ball Cannon*—A device capable of shooting a ball at speeds up to 220 ft/s (67.1 m/s, 150 mph). Balls shall be oriented to impact the strike surface between the stitches. Typical pitching machines cannot yield the aiming accuracy required by these test methods. Cannon exhaust air must not cause motion of the bat in the absence of an impact.

5.2.2 *Ball Speed Gate*—Light screens capable of measuring a ball traveling at speeds up to 220 ft/s (67.1 m/s, 150 mph), with an accuracy of at least ± 0.7 ft/s (± 0.2 m/s). The device shall measure across a length of no less than half the ball diameter to avoid centering error. The first sensor shall be located no more than 12.0 in. (304.8 mm) from the bat surface. The second sensor shall be located 6 ± 0.03 in. (152 ± 0.8 mm) after the first sensor (see Fig. 1). The ball speed gate must measure the ball rebound speed.

5.2.3 *Ball Angle Measurement*—Measure and record the ball vertical and horizontal rebound angles within 1° , using at least one of the following or equivalent devices.

5.2.3.1 *Angled Light Gates*—A light trap device capable of measuring the ball rebound angle after impact with a bat (see Fig. 2). The device shall measure across a length of no less than half the ball diameter to avoid centering error. The vertical rebound angle gate shall be mounted at approximately 45° relative to the inbound ball path. The horizontal rebound angle gate shall be mounted at approximately 25° relative to the inbound ball path (to provide room for the speed gates). (Appendix X1.)

5.2.3.2 *High Speed Camera*—A high speed video camera capable of recording the ball rebound path. If a mirror is placed at 45° atop the light box, one video camera can observe both the horizontal and vertical planes. (Appendix X2.)

5.2.4 *Bat Pivot Support*—A turntable, rotating in the horizontal plane, with clamps to support and align the bat in the path of the ball. The rotating clamp and shaft assembly shall not weigh more than 6 lb (2.7 kg) and shall spin freely via ball bearings (see Fig. 1). The MOI of the clamp turntable assembly shall be determined, recorded, and used in the performance calculations. The MOI for the clamp turntable assembly shall not exceed 300 oz-in.² (5498 kg-mm²).

5.2.5 *Bat Speed Sensor*—Device to measure bat rotational speed for at least 100° after impact. Device shall read speeds up to $3000^\circ/s$ with an accuracy of at least $1^\circ/s$ (found to be achievable using an optical encoder). Bat speed is taken from the slope of the linear least-squares fit to the bat rotation versus time data between 5° and 95° after impact.

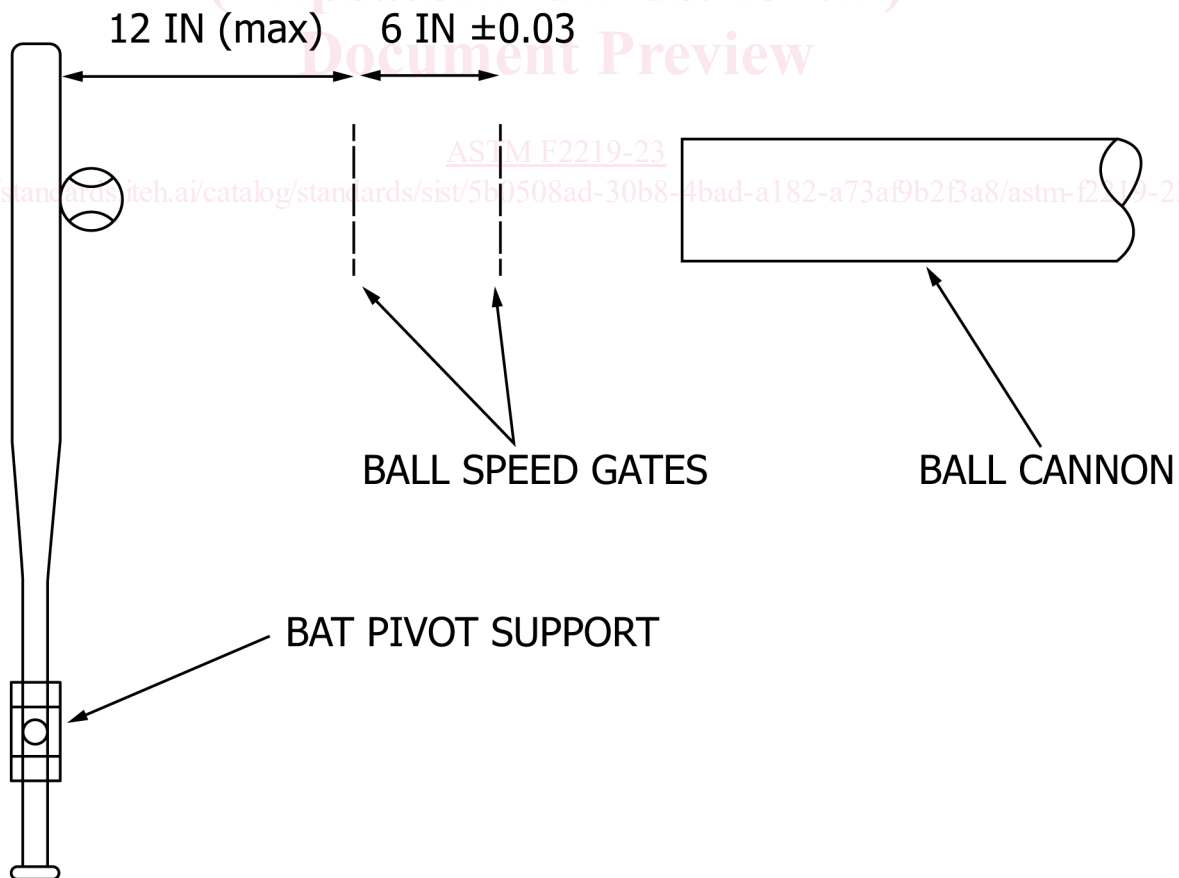

FIG. 1 Bat Testing Machine

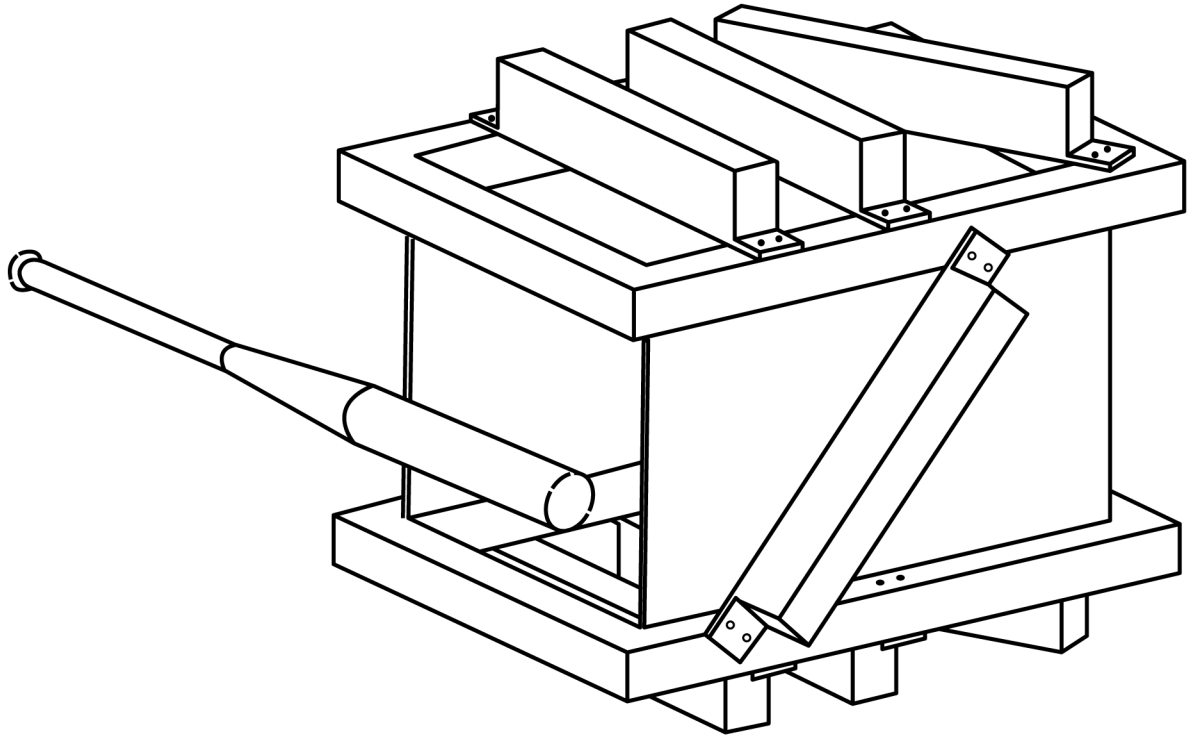

FIG. 2 Diagram Showing Light Gate Arrangement to Measure the Ball Speed, the Horizontal Rebound Angle, and the Vertical Rebound Angle

6. Calibration and Standardization

6.1 *Ball Speed Gate*—The distance between the sensors of the speed gates should be measured and recorded.

6.2 *Reference Standards and Blanks*—A standard bat and ball shall be used for monthly reference purposes to verify proper machine operation.

6.3 *Location Tolerance:*

6.3.1 *Bat*—Coat the impact area of the bat with a removable material (dry erase marker or powder).

6.3.2 *Ball*—Impact the bat with a solid coverless ball such as a pitching machine baseball or softball core.

6.3.3 *Location*—For each impact, use the average of the ball contact edges on the bat as the impact location. The impact location is the average location from six balls.

6.3.4 *Tolerance*—The standard deviation of the six impacts must be less than 0.125 in. The difference between the target location and the average location from the six impacts must be less than 0.125 in.

7. Conditioning

7.1 *Ball and Bat Conditioning and Test Room Conditions:*

7.1.1 Test balls shall be stored in an environmentally controlled space for at least 14 days immediately before testing. Wood bats shall be stored at these environmental conditions for at least 24 h prior to testing. Non-wood bats shall be stored at these test environmental conditions for at least 2 h prior to testing.

7.1.2 Temperature is to be maintained at $72 \pm 4^\circ\text{F}$ ($22 \pm 2^\circ\text{C}$).

7.1.3 Relative humidity (RH) is to be maintained between 40 and 60 %.

7.1.4 Temperature and relative humidity are to be measured and recorded hourly within $\pm 0.5^\circ\text{F}$ ($\pm 0.3^\circ\text{C}$) and $\pm 2\%$ RH over the conditioning and test duration.

8. Procedure

8.1 *Determination of Bat Features and Test Location*—Determine bat balance point (BP) and bat MOI in accordance with Test Method F2398.

8.2 Select a performance measure (BBCOR or BBS) as specified by the test sponsor.

8.3 *Bat Test Procedure:*

8.3.1 Select a test ball meeting requirement of 5.1. Rotate the ball in the cannon between impacts so that the impact area of the ball is different for each impact. Record the ball weight, compression (Test Method F1888), COR (Test Method F1887), and circumference. If the results are normalized, record the values of *DS* and *CCOR* (Test Method F2845).

8.3.2 Set ball cannon to fire the ball at the desired test speed (60 to 150 mph) as determined by the test sponsor.

8.3.3 Mount the bat in the clamps of the bat pivot support. Locate the bat pivot to provide a ball impact near the maximum performance location (often 6 in. from the barrel end of the bat).

8.3.4 Locate the bat against the start position (see Fig. 1).

8.3.5 Load the selected test ball in ball cannon. Orient the test ball so that its impact with the bat will occur between the stitches of the ball.

8.3.6 Shoot the ball at the bat, observing all safety precautions.

8.3.7 Verify proper bat alignment by observing the rebound path of the ball after impact with the bat. The rebound angle should be within 10° of the inbound path.

8.3.8 Record the ball inbound speed, ball rebound speed, and the bat rebound speed. For inbound speeds below 120 mph, the inbound speed must be within ±1 mph of the target speed. For inbound speeds above 120 mph, the inbound speed must be within ±2 mph of the target speed.

8.3.9 Calculate the ball rebound speed from the bat speed using:

$$v_r' = (I + I_{pivot}) \frac{\omega}{mQ} - v_i \quad (1)$$

where:

- Q = distance from the impact location and pivot point location, in. (m),
- v_r' = ball rebound speed found from the bat speed, in./s (m/s),
- ω = bat rotational speed, rad/s,
- I = moment of inertia (MOI) of bat (Test Method F2398), oz-in.² (kg-m²),
- I_{pivot} = moment of inertia of pivot stage, oz-in.² (kg-m²),
- v_i = ball inbound speed, in./s (m/s), and
- m = weight of the test ball, oz (g).

8.3.10 Calculate the momentum ratio, L , using:

$$L = 1 - \frac{v_i}{(v_r' - v_r + v_i)} \quad (2)$$

where:

- L = the ratio of the momentum after impact divided by the momentum before impact minus one, and
- v_r = ball rebound speed, in./s (m/s).

For impacts where both the bat and ball rebound speeds are measured, check that the angular momentum about the pivot is conserved. Do not use impacts where $L > 0.02$. For recurring large L , check the ball rebound angle, I , Q , m , and I_{pivot} .

8.3.11 Record and store results from all impacts as requested by test sponsor.

8.3.12 Identify the maximum performance location by moving the impact location in 1/2-in. increments. The minimum BBCOR on both sides of the peak must be at least 0.5 % less than the peak performance.

9. Calculation of Results

9.1 BBCOR:

9.1.1 Calculate the bat-ball coefficient of restitution (BBCOR) for each valid impact using Eq 3 and Eq 4:

$$BBCOR = \frac{v_i + v_r}{v_i} \left(\frac{m}{M_e} + 1 \right) - 1 \quad (3)$$

$$\frac{1}{M_e} = \frac{1}{W} + \frac{(Q + 6 - BP)^2}{[I - W(BP - 6)^2]} \quad (4)$$

where:

- M_e = effective bat mass, oz (g),
- W = bat weight, oz (g), and

BP = balance point (Test Method F2398), in. (m).

9.1.2 To normalize bat performance for ball variation, calculate the normalized BBCOR for each valid impact using Eq 5 and Eq 6:

$$BBCOR_N = \sqrt{\frac{r_s CCOR_S^2 + 1}{1 + r_s}} \quad (5)$$

$$r_s = \frac{DS}{DS_S} \left(\frac{1 - BBCOR^2}{BBCOR^2 - CCOR^2} + 1 \right) - 1 \quad (6)$$

where:

- $BBCOR_N$ = normalized BBCOR,
- r_s = ratio of bat stiffness to the stiffness of a standard ball,
- DS = dynamic stiffness of the test ball, Test Method F2845 (lb/in),
- DS_S = dynamic stiffness of the standard ball, provided by the test sponsor (lb/in),
- $CCOR$ = cylindrical coefficient of restitution of the test ball, Test Method F2845, and
- $CCOR_S$ = cylindrical coefficient of restitution of the standard ball, provided by the test sponsor.

9.1.3 Calculate the average BBCOR for the test bat from the six valid impacts using Eq 7:

$$BBCOR_{avg} = \frac{1}{6} (BBCOR_1 + BBCOR_2 + \dots + BBCOR_6) \quad (7)$$

9.1.4 To obtain the bat performance using the bat speed, in Eq 3 replace v_r with v_r' (from Eq 1).

9.1.5 To normalize bat performance with the ball CCOR and DS, in Eq 7 replace BBCOR with $BBCOR_N$ (from Eq 5).

9.2 e_a :

9.2.1 Calculate the collision efficiency (e_a) of the test bat impact normalized to a standard ball of mass, m_s , using Eq 8:

$$e_a = \frac{BBCOR - \frac{m_s}{M_e}}{1 + \frac{m_s}{M_e}} \quad (8)$$

where:

- m_s = weight of the standard ball, provided by the test sponsor, oz (kg).

9.3 BBS:

9.3.1 Calculate the batted-ball speed (BBS) value of the test bat using Eq 9:

$$BBS = v_p e_a + v_b (1 + e_a) \quad (9)$$

where:

- v_b = bat swing speed (mph or m/s) supplied by the test sponsor, and
- v_p = ball pitch speed (mph or m/s), supplied by the test sponsor.

9.3.2 Calculate the average batted ball speed (BBS) value of the test bat from the six valid impacts using Eq 10:

$$BBS_{avg} = \frac{1}{6} (BBS_1 + BBS_2 + \dots + BBS_6) \quad (10)$$