



Designation: F336 – 02 (Reapproved 2023)

# Standard Practice for Design and Construction of Nonmetallic Enveloped Gaskets for Corrosive Service<sup>1</sup>

This standard is issued under the fixed designation F336; the number immediately following the designation indicates the year of original adoption or, in the case of revision, the year of last revision. A number in parentheses indicates the year of last reapproval. A superscript epsilon ( $\epsilon$ ) indicates an editorial change since the last revision or reapproval.

## 1. Scope

1.1 This practice covers the designs, sizes, classifications, and construction of enveloped gaskets for severe corrosive applications. The envelope serves as the corrosion resistant member of the composite gasket and is a nonmetallic material such as polytetrafluoroethylene, PTFE, or related materials. The inserts are nonmetallic gasketing materials with or without metal reinforcement. Other types of composite gaskets are covered in Classification F868.

1.2 This standard is based directly upon ANSI B16.21–2011; for that reason units are as ANSI stated in inches.

1.3 *This standard does not purport to address all of the safety concerns, if any, associated with its use. It is the responsibility of the user of this standard to establish appropriate safety, health, and environmental practices and determine the applicability of regulatory limitations prior to use.*

1.4 *This international standard was developed in accordance with internationally recognized principles on standardization established in the Decision on Principles for the Development of International Standards, Guides and Recommendations issued by the World Trade Organization Technical Barriers to Trade (TBT) Committee.*

## 2. Referenced Documents

2.1 *ASTM Standards:*<sup>2</sup>

D3294 Specification for Polytetrafluoroethylene (PTFE) Resin Molded Sheet and Molded Basic Shapes

D3308 Specification for PTFE Resin Skived Tape

F104 Classification System for Nonmetallic Gasket Materials

F112 Test Method for Sealability of Enveloped Gaskets

<sup>1</sup> This practice is under the jurisdiction of ASTM Committee F03 on Gaskets and is the direct responsibility of Subcommittee F03.10 on Composite Gaskets.

Current edition approved April 1, 2023. Published April 2023. Originally approved in 1971. Last previous edition approved in 2016 as F336 – 02 (2016). DOI: 10.1520/F0336-02R23.

<sup>2</sup> For referenced ASTM standards, visit the ASTM website, www.astm.org, or contact ASTM Customer Service at service@astm.org. For *Annual Book of ASTM Standards* volume information, refer to the standard's Document Summary page on the ASTM website.

F868 Classification for Laminated Composite Gasket Materials

2.2 *Other Document:*

ASME B16.21 – 2011 Nonmetallic Flat Gaskets for Pipe Flanges<sup>3</sup>

## 3. Significance and Use

3.1 The gaskets covered by this practice can be used on, but are not limited to, equipment constructed of the following materials: (a) stoneware, (b) glass and glass-lined, (c) tantalum (solid and lined), (d) titanium (solid and lined or clad), (e) zirconium (solid and lined or clad), (f) silver (solid and lined), and (g) nickel and nickel alloys (solid and clad).

3.2 The gaskets provided for herein are for the following: (a) pipe flanges (flat or raised face), (b) vessel nozzles, (c) circular openings in vessels in excess of 12 in. (305 mm) diameter, and (d) oval openings in vessels.

## 4. Sizes

4.1 The gasket nominal size listed in inches, Table 1, will be the same as used on the following pipe flanges in accordance with ASME B16.21 – 2011:

Pipe Size	ASME
½ to 24 in.	B16.21 – 1992, Table 5 and 6
Over 24 in.	B16.21 – 1992, Table 1 and 2

4.2 Commercial dimensional tolerances apply, unless otherwise agreed upon between the seller and the purchaser.

## 5. Materials and Manufacture

5.1 The gaskets covered by this practice shall be made of nonmetallic materials, except when a metal support is desired in the insert.

5.2 Materials should be selected, both for inserts and envelopes, that will withstand the conditions under which they are to be subjected in service.

5.3 A list of reference literature for determining material suitability in corrosive environments is available from ASTM

<sup>3</sup> Available from American Society of Mechanical Engineers, Three Park Avenue, New York, NY 10016.

**TABLE 1 Nominal Gasket Sizes<sup>A</sup>**

NOTE 1—Refer to Fig. 1 through Fig. 6 for explanation of gasket component details.

NOTE 2—Split design inserts not to be smaller than nominal pipe size.

NOTE 3—Inside diameter of folded and machined design envelopes will adjoin the insert inside diameter assuring noninterference with flow through pipe.

NOTE 4—Full face gaskets shall have envelope outside diameter same as ring gasket outside diameter.

NOTE 5—Sizes 14 in. (356 mm) and larger may be made from machined envelopes depending upon material shape availability.

Nominal Pipe Size, in.	Insert (2) (See Note 1)		Envelope (1) (See Note 1)			
	II. Inside Diameter (B)	III. Full Face Outside Diameter (D)	IV. Flat Ring Gasket Outside Diameter (C)	V. (Each Side) Thickness	VI. Inside Diameter (A)	VII. Outside Diameter (C)
	in.	in.	in.	in.	in.	in.
1/2	0.84	3.50	1.88	0.015	0.50	1.88
3/4	1.06	3.88	2.25	0.015	0.75	2.25
1	1.31	4.25	2.62	0.020	1.00	2.62
1 1/4	1.66	4.63	3.00	0.020	1.25	3.00
1 1/2	1.91	5.00	3.38	0.020	1.50	3.38
2	2.38	6.00	4.12	0.020	2.00	4.12
2 1/2	2.88	7.00	4.88	0.020	2.50	4.88
3	3.50	7.50	5.38	0.020	3.00	5.38
3 1/2	4.00	8.50	6.38	0.020	3.50	6.38
4	4.50	9.00	6.88	0.020	4.00	6.88
5	5.56	10.00	7.75	0.020	5.00	7.75
6	6.62	11.00	8.75	0.020	6.00	8.75
8	8.62	13.50	11.00	0.020	8.00	11.00
10	10.75	16.00	13.38	0.020	10.00	13.38
12	12.75	19.00	16.13	0.020	12.00	16.12
14	14.00	21.00	17.75	0.015	not applicable—see Note 5	17.00
16	16.00	23.50	20.25	0.015	see Note 5	19.00
18	18.00	25.00	21.62	0.015		21.00
20	20.00	27.50	23.88	0.015		23.00
24	24.00	32.00	28.25	0.015		27.00
30	30.00	38.75	34.75	0.015		33.00
36	36.00	46.00	41.25	0.015		39.00
42	42.00	53.00	48.00	0.015		45.00
48	48.00	59.50	54.50	0.015		51.00
54	54.00	66.25	61.75	0.015		57.00
60	60.00	73.00	68.12	0.015		63.00
72	72.00	86.50	81.38	0.015		75.00
84	84.00	99.75	94.25	0.015		87.00
96	96.00	113.25	107.25	0.015		99.00

<sup>A</sup> Extracted from American National Standard Neometallic Gaskets for Pipe Sizes (ANSI B16.21–2011), with the permission of the publisher. The American Society of Mechanical Engineers, United Engineering Center, Three Park Avenue, New York, NY 10016.

Headquarters. It is entitled, “Materials of Construction ASTM F-3.50.10 Corrosion Data Literature.”<sup>4</sup>

5.4 The design of the envelope classifies the enveloped gasket as follows:

5.4.1 *Split*, knife cut (Fig. 1 and Fig. 2).

5.4.2 *Machined* (Fig. 3 and Fig. 4).

5.4.3 *Tape Folded*, made endless by joining tape ends with a heat sealing procedure (Fig. 5 and Fig. 6).

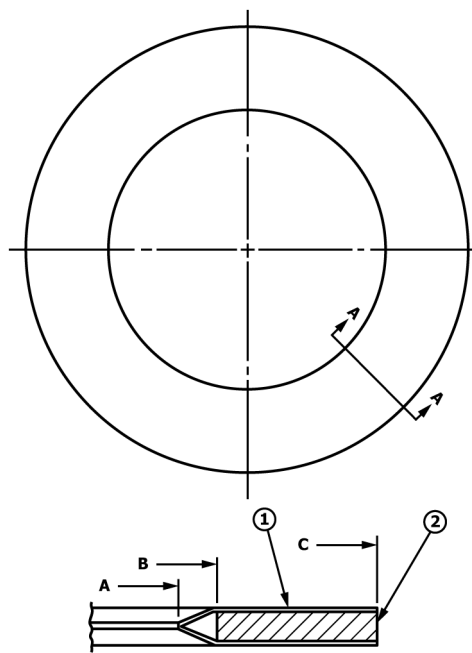

**FIG. 1 Split Design (Flat Ring)**

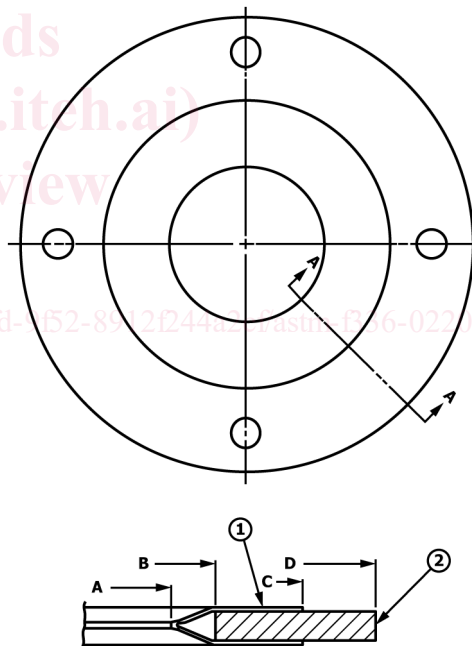

**FIG. 2 Split Design (Full Face)**

**6. Insert Classification<sup>5</sup>**

6.1 *Constructions*—Two insert constructions are covered as follows:

6.1.1 *Construction 1*—Single layer.

6.1.2 *Construction 2*—Multiple layer.

<sup>4</sup> Supporting data have been filed at ASTM International Headquarters and may be obtained by requesting Research Report RR:F03-1001.

<sup>5</sup> See Fig. 1 through Fig. 6.

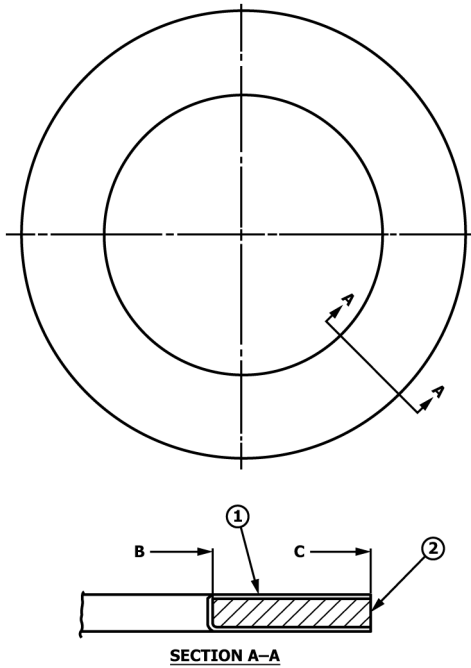

FIG. 3 Machined Design (Flat Ring)

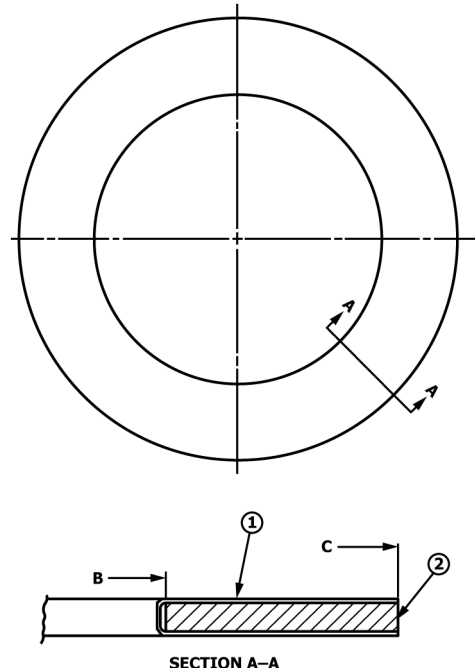

FIG. 5 Folded Design (Flat Ring)

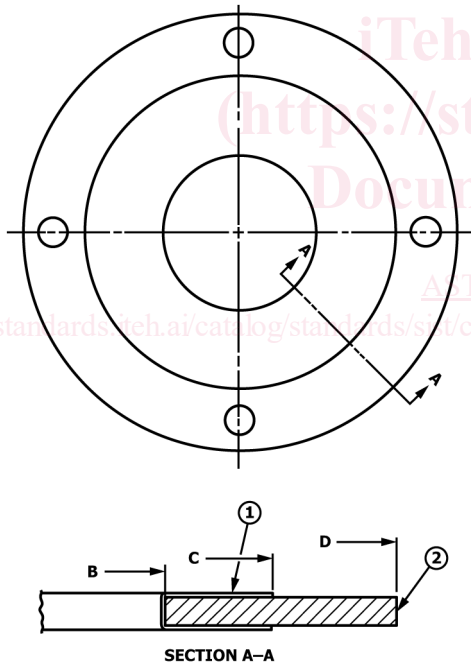

FIG. 4 Machined Design (Full Face)

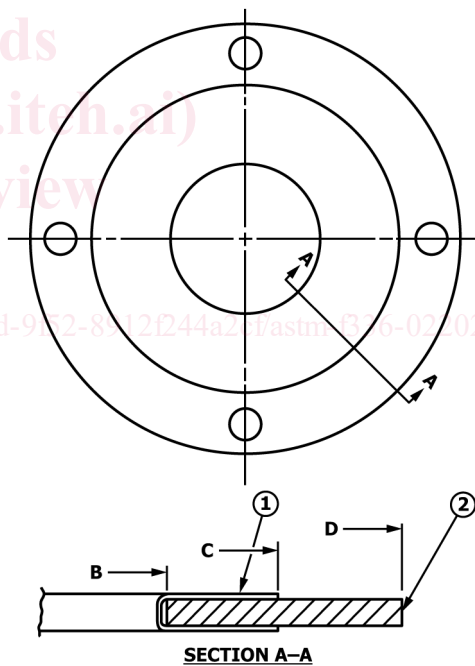

FIG. 6 Folded Design (Full Face)

6.2 *Grades*—Multiple layer constructions include the following:

6.2.1 *Grade 1*—Two layers, any combination of nonmetallic homogenous materials.

6.2.2 *Grade 2*—Three layers, any combination of nonmetallic homogenous materials.

6.2.3 *Grade 3*, Three layers, the two outer layers nonmetallic homogenous materials, the inner layer (core) metallic.

6.3 *Type*—This classification covers insert material types as follows:

6.3.1 *Nonmetallic*—Any recognized nonmetallic gasket material in accordance with Classification **F104**, taking into consideration limitations with regard to temperature and pressure.

6.3.2 *Metallic*—Inner layer (core) metallic material in Construction 2, Grade 3.

6.3.2.1 Flat solid metal center.

6.3.2.2 Corrugated metal center.

6.3.2.3 Perforated metal center.

6.3.2.4 Braided metal center.