

INTERNATIONAL  
STANDARD

**ISO**  
**5456-1**

First edition  
1996-06-15

---

---

**Technical drawings — Projection methods —**

**Part 1:**  
Synopsis

iTeh Standards  
(<https://standards.itih.ai>)  
*Dessins techniques — Méthodes de projection —*  
*Partie 1: Récapitulatif*  
Document Preview

[ISO 5456-1:1996](https://standards.itih.ai/catalog/standards/iso/5bd53ce8-5cc1-4c36-ac37-ce7a09a7abdf/iso-5456-1-1996)

<https://standards.itih.ai/catalog/standards/iso/5bd53ce8-5cc1-4c36-ac37-ce7a09a7abdf/iso-5456-1-1996>



Reference number  
ISO 5456-1:1996(E)

## Foreword

ISO (the International Organization for Standardization) is a worldwide federation of national standards bodies (ISO member bodies). The work of preparing International Standards is normally carried out through ISO technical committees. Each member body interested in a subject for which a technical committee has been established has the right to be represented on that committee. International organizations, governmental and non-governmental, in liaison with ISO, also take part in the work. ISO collaborates closely with the International Electrotechnical Commission (IEC) on all matters of electrotechnical standardization.

Draft International Standards adopted by the technical committees are circulated to the member bodies for voting. Publication as an International Standard requires approval by at least 75 % of the member bodies casting a vote.

International Standard ISO 5456-1 was prepared by Technical Committee ISO/TC 10, *Technical drawings, product definition and related documentation*, Subcommittee SC 1, *Basic conventions*.

ISO 5456 consists of the following parts, under the general title *Technical drawings — Projection methods*:

- Part 1: *Synopsis*
- Part 2: *Orthographic representations*
- Part 3: *Axonometric representations*
- Part 4: *Central projection*

Annex A of this part of ISO 5456 is for information only.

## Introduction

In the broad field of technical activities, various projection methods are used to represent objects. All these methods have their own merits, but also their inherent disadvantages.

The normal technical drawing is often an orthogonal projection, in which related representations of more than one view are utilized (see ISO 5456-2) to draw and completely define any object by means of carefully chosen views, cuts and sections.

However, the execution of such two-dimensional representations requires an understanding of both the projection method and its interpretation, so that the observer will be able to synthesize the single views into a three-dimensional object.

For many technical fields and their stages of development, however, it is necessary to provide an easily understood picture to observers. Such drawings, called pictorial representation, provide a three-dimensional view of an object as it would appear to the observer. No special technical training for reading pictorial representations is necessary.

Pictorial representations may be presented on their own or may supplement orthogonal drawings.

Various methods of pictorial representations exist, but their nomenclatures differ, and may be used even contradictorily.

The steady increase in global technical intercommunication, as well as the evolution of methods of computer-aided design and draughting with their various types of three-dimensional representations, suggest the need for ISO/TC 10 to clarify this problem.

The rules and conventions given in ISO 5456 should be used, in accordance with ISO 128, for all types of technical drawings and in all fields of technical activities, such as:

- mechanical and construction drawings;
- manuals and instruction books;
- X-ray views;
- exploded views.

**iTeh Standards**  
**(<https://standards.itih.ai>)**  
**Document Preview**

This page intentionally left blank

[ISO 5456-1:1996](#)

<https://standards.itih.ai/catalog/standards/iso/5bd53ce8-5cc1-4c36-ac37-ce7a09a7abdf/iso-5456-1-1996>

# Technical drawings — Projection methods —

## Part 1: Synopsis

### 1 Scope

This part of ISO 5456 gives a survey of the various types of projection methods as well as their geometric relationships.

Parts 2 to 4 specify details for the selection and application of the various projection methods.

### 2 Normative references

The following standards contain provisions which, through reference in this text, constitute provisions of this part of ISO 5456. At the time of publication, the editions indicated were valid. All standards are subject to revision, and parties to agreements based on this part of ISO 5456 are encouraged to investigate the possibility of applying the most recent editions of the standards indicated below. Members of IEC and ISO maintain registers of currently valid International Standards.

ISO 1503:1977, *Geometrical orientation and directions of movements*.

ISO 5456-2:1996, *Technical drawings — Projection methods — Part 2: Orthographic representations*.

ISO 5456-3:1996, *Technical drawings — Projection methods — Part 3: Axonometric representations*.

ISO 5456-4:1996, *Technical drawings — Projection methods — Part 4: Central projection*.

ISO 10209-1:1992, *Technical product documentation — Vocabulary — Part 1: Terms relating to technical drawings: general and types of drawings*.

ISO 10209-2:1993, *Technical product documentation — Vocabulary — Part 2: Terms relating to projection methods*.

### 3 Definitions

For the purposes of this part of ISO 5456, the definitions given in ISO 10209-1 and ISO 10209-2 and the following definitions apply.

**3.1 pictorial representation:** Parallel or central projection on a single projection plane giving a three-dimensional image of an object.

**3.2 true view:** View of the features of an object that lie on a plane parallel to the projection plane; geometrically similar to the corresponding features of the object.

**3.3 exploded view:** Drawing of an assembly in pictorial representation in which all the components are drawn to the same scale and correctly orientated relative to each other, but are separated from each other in their correct sequence along common axes.

NOTE 1 This term should not be confused with representations where a covering layer is removed in order to show inner portions like those presented in section (cut-away view).

**3.4 principal view:** View of an object showing the important features, which may be chosen from the point of view of design, assembly, sales, service or maintenance.

### 4 Survey of projection methods

Projection methods are defined by:

- the type of projectors, which may be either parallel or convergent;

- the position of the projection plane in relation to the projectors, either orthogonal or oblique;
- the position of the object (its main features), which may be either parallel/orthogonal or oblique to the projection plane.

A survey of the various possibilities and their relationships is given in table 1.

## 5 Geometrical orientation

Geometrical orientation in space is given by coordinate axes and coordinate planes in accordance with the arrangement given by the right-hand rule (see ISO 1503).

### 5.1 Coordinate axes

Coordinate axes are imaginary lines in space which intersect at right angles to each other at the origin.

There are three coordinate axes: X, Y and Z (see figure 1), to be designated by capital letters.

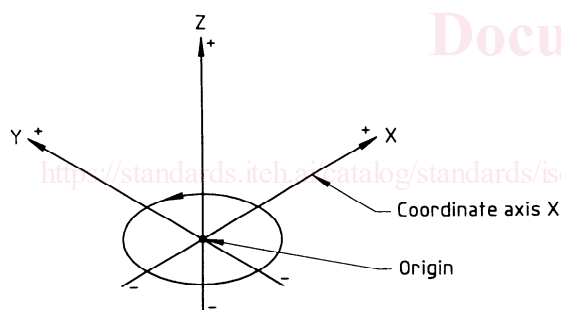

Figure 1

### 5.2 Coordinate planes

Three imaginary planes in space which intersect each other at right angles. Each of the three coordinate planes is defined by two coordinate axes and includes the origin. They are designated by capital letters XY, YZ and XZ (see figure 2).

NOTE 2 Coordinate planes and projection planes are not always the same, therefore, if necessary, appropriate indication (designation) should be shown on the drawing.

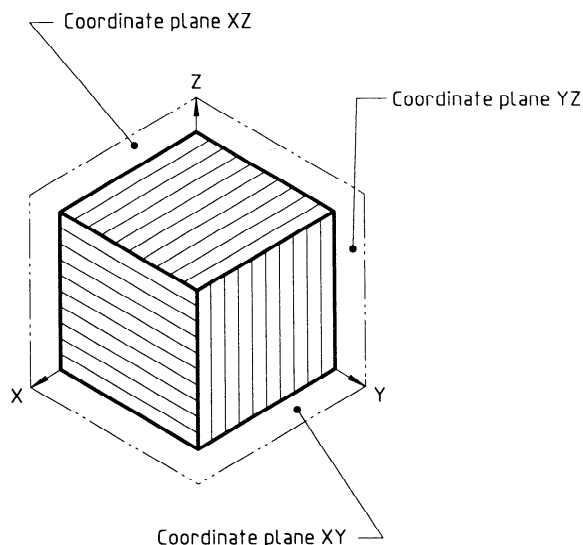

Figure 2

## 6 Invariables

Depending on the projection method chosen, certain features of the object are represented in true view as follows:

### 6.1 The central projection invariable is:

- the size of angles in planes which are parallel to the projection plane; therefore the projection plane figures lying in planes parallel to the projection plane are similar.

### 6.2 Oblique projection invariables are:

- the parallelism of lines, unless they are parallel to the projection lines;
- the divisional ratio of lines;
- the size of angles, length of lines and all plane figures in planes parallel to the projection plane.

### 6.3 Orthogonal projection invariables are:

- the parallelism of lines, unless they are parallel to the projection lines;
- the divisional ratio of lines;
- the size of angles, length of lines and all plane figures in planes parallel to the projection plane;
- right angles, if one side of the right angle in the object is parallel to the projection plane.