



Designation: **E223—16 E223 – 23**

Standard Test Methods for Analysis of Sulfuric Acid¹

This standard is issued under the fixed designation E223; the number immediately following the designation indicates the year of original adoption or, in the case of revision, the year of last revision. A number in parentheses indicates the year of last reapproval. A superscript epsilon (ϵ) indicates an editorial change since the last revision or reapproval.

This standard has been approved for use by agencies of the U.S. Department of Defense.

1. Scope*

1.1 These test methods cover the analysis of sulfuric acid.

1.2 The following applies for the purposes of determining the conformance of the test results using this test method to applicable specifications, results shall be rounded off in accordance with the rounding-off method of Practice E29.

1.3 The values stated in SI units are to be regarded as standard. The values given in parentheses are for information only.

1.4 The analytical procedures appear in the following order:

| | |
|--------------------|----------|
| Total Acidity | Sections |
| Baumé Gravity | 8 to 16 |
| Nonvolatile Matter | 17 to 26 |
| Iron | 27 to 33 |
| Sulfur Dioxide | 34 to 43 |
| Arsenic | 44 to 51 |
| | 52 to 61 |

1.5 *This standard does not purport to address all of the safety concerns, if any, associated with its use. It is the responsibility of the user of this standard to establish appropriate safety, health, and environmental practices and determine the applicability of regulatory limitations prior to use. Consult current OSHA regulations, suppliers' Safety Data Sheets, and local regulations for all materials used in this specification. Specific hazards statements are given in Section 5.*

1.6 *This international standard was developed in accordance with internationally recognized principles on standardization established in the Decision on Principles for the Development of International Standards, Guides and Recommendations issued by the World Trade Organization Technical Barriers to Trade (TBT) Committee.*

2. Referenced Documents

2.1 *ASTM Standards:*²

[D1193 Specification for Reagent Water](#)

[D6809 Guide for Quality Control and Quality Assurance Procedures for Aromatic Hydrocarbons and Related Materials](#)

[E1 Specification for ASTM Liquid-in-Glass Thermometers](#)

¹ These test methods are under the jurisdiction of ASTM Committee D16 on Aromatic, Industrial, Specialty and Related Chemicals and are the direct responsibility of Subcommittee D16.10 on Acids.

Current edition approved April 1, 2016 April 1, 2023. Published May 2016 April 2023. Originally approved in 1965. Last previous edition approved in 2008 2016 as E223—08: E223 – 16. DOI: 10.1520/E0223-16-10.1520/E0223-23.

² For referenced ASTM standards, visit the ASTM website, www.astm.org, or contact ASTM Customer Service at service@astm.org. For *Annual Book of ASTM Standards* volume information, refer to the standard's Document Summary page on the ASTM website.

*A Summary of Changes section appears at the end of this standard

- [E29 Practice for Using Significant Digits in Test Data to Determine Conformance with Specifications](#)
- [E60 Practice for Analysis of Metals, Ores, and Related Materials by Spectrophotometry](#)
- [E100 Specification for ASTM Hydrometers](#)
- [E180 Practice for Determining the Precision of ASTM Methods for Analysis and Testing of Industrial and Specialty Chemicals \(Withdrawn 2009\)³](#)
- [E200 Practice for Preparation, Standardization, and Storage of Standard and Reagent Solutions for Chemical Analysis](#)
- [E300 Practice for Sampling Industrial Chemicals](#)

3. Significance and Use

3.1 These test methods provide for the classification of various grades of sulfuric acid and for the determination of various impurities. Acid strength and impurity levels are important factors in many uses of sulfuric acid.

4. Purity of Reagents

4.1 *Purity of Reagents*—Reagent grade chemicals shall be used in all tests. Unless otherwise indicated, it is intended that all reagents shall conform to the specifications of the Committee on Analytical Reagents of the American Chemical Society, where such specifications are available.⁴ Other grades may be used, provided it is first ascertained that the reagent is of sufficiently high purity to permit its use without lessening the accuracy of the determination.

4.2 *Purity of Water*—Unless otherwise indicated, references to water shall be understood to mean Type HI or Type HHI reagent water conforming to Specification **D1193**.

5. Hazards

5.1 Consult current OSHA regulations, suppliers' Safety Data Sheets, and local regulations for all materials used in this test method. Use of safety goggles and gloves highly recommended.

5.2 Sulfuric acid is a strong corrosive acid and is dangerous if improperly handled. Avoid any skin or eye contact.

5.3 Clean up all spills immediately by covering the spill with vermiculite or some other inert absorbent material and sweeping into a pan. Dispose of the absorbent by flooding with water and discarding in a suitable container. Flush the area with water.

6. Photometers and Photometric Practice

6.1 Photometers and the photometric practice used in these test methods shall conform to Practice **E60**.

7. Sampling

7.1 Sampling of sulfuric acid is not within the scope of these test methods. Sample sulfuric acid in accordance with the appropriate sections of Practice **E300** methods for simple liquids.

TABLE 1 Sample Size for Total Acidity

| H ₂ SO ₄ , % mass (m/m) | Sample Size, g |
|---|----------------|
| 98 | 1.9 to 2.2 |
| 94 | 2.0 to 2.3 |
| 90 | 2.1 to 2.4 |
| 85 | 2.2 to 2.6 |
| 80 | 2.3 to 2.7 |
| 77 | 2.4 to 2.8 |
| 75 | 2.5 to 2.9 |

³ The last approved version of this historical standard is referenced on www.astm.org.

⁴ *Reagent Chemicals, American Chemical Society Specifications*; *ACS Reagent Chemicals, Specifications and Procedures for Reagents and Standard-Grade Reference Materials*, American Chemical Society, Washington, DC. For suggestions on the testing of reagents not listed by the American Chemical Society, see *Analar Standards for Laboratory Chemicals*, BDH Ltd., Poole, Dorset, U.K., and the *United States Pharmacopeia and National Formulary*, U.S. Pharmacopeial Convention, Inc. (USP); (USPC), Rockville, MD.

7.2 The sample to be analyzed shall be considered to be that sample in a single bottle submitted to the analytical laboratory.

7.3 The size of the sample shall be sufficient to perform all analyses without the reuse of any portion of the sample.

TOTAL ACIDITY

8. Scope

8.1 This test method covers the determination of the total acidity of 75.75 % to 99 % mass (m/m) sulfuric acid. Two test methods are given for weighing the sample, namely, the Dely tube and the snake tube test methods.

9. Summary of Test Method

9.1 A weighed sample of acid is diluted in water and titrated with standardized 0.5 meq/mL(N) sodium hydroxide solution, using phenolphthalein as the indicator.

10. Interferences

10.1 Acids other than sulfuric and compounds that consume sodium hydroxide will affect the accuracy of this test method.

11. Apparatus

11.1 *Dely Tube (Fig. 1) or Snake Tube (Fig. 2).*⁵

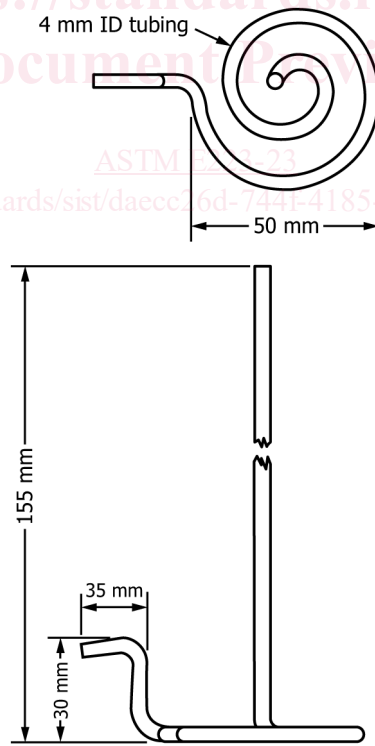

FIG. 1 Dely Tube

⁵ The sole source of supply of the Suitable Dely and snake tubes known to the committee at this time is Corning Glass Works, Corning, NY. If you are aware of alternative suppliers, please provide this information to ASTM International Headquarters. Your comments will receive careful consideration at a meeting of the responsible technical committee,¹ which you may attend.

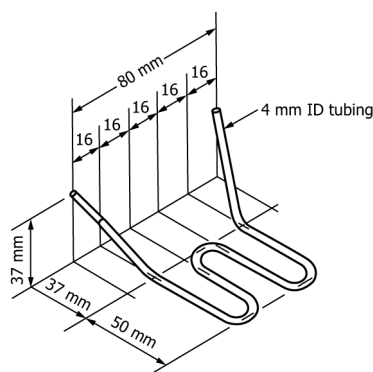

FIG. 2 Snake Tube

11.2 *Buret*, ~~400-mL~~, 100 mL, Class A, bulb-type.

12. Reagents

12.1 *Phenolphthalein Indicator Solution* (10 g/L)—Dissolve 1 g of phenolphthalein in 100 mL of ethanol (95 %), methanol, or isopropanol.⁶

12.2 *Sodium Hydroxide, Standard Solution* (0.5 meq/mL(N))—See Practice E200.

13. Procedure

13.1 *Dely Tube Test Method*—Invert the sample bottle several times. (Hold the stopper in tight.) Insert the long arm of a dry, weighed Dely tube and withdraw by suction a convenient size sample depending upon the acid strength as given in Table 1 (Note 1). Invert the Dely tube and wipe the acid from the long arm with disposable tissue several layers thick. Discard the tissue immediately to avoid burning the fingers. Reweigh to the nearest 0.0001 g and record the weight of the sample. Incline the tube so that the acid runs back nearly to the bend of the short arm. Attach the short arm to an elevated water reservoir by means of a rubber tube closed near the lower end with a pinch clamp. Insert the long arm of the Dely tube into ~~400-mL~~ 400 mL glass beaker containing approximately 100 mL of water. Open the pinch clamp and flush the sample into the beaker. Continue the flow of water until all acid is washed from the Dely Tube (Note 2 and Note 3). Wash the long end of the Dely tube, collecting the washings in the beaker. Add 3 to 5 drops of phenolphthalein indicator solution. Record the temperature of the 0.5 meq/mL(N) NaOH solution, and then titrate the sample to a pink end point. Record the titration to the nearest 0.02 mL.

NOTE 1—The Dely tube can be marked at points equivalent to weights given in Table 1.

NOTE 2—The presence of acid in the Dely tube may be detected by coloring the water in the reservoir with phenolphthalein indicator and the minimum amount of dilute NaOH solution that will produce a slight pink. The water flowing through the tube is dicolorized as long as acid is present, and the appearance of a pink color indicates the absence of acid.

NOTE 3—The acid and water are separated by a bubble of air.

13.2 *Snake Tube Test Method*—Invert the sample bottle several times. (Hold the stopper in tight). Insert the capillary end of a dry, weighed snake tube and withdraw by suction a convenient size sample depending upon the acid strength as given in Table 1. Invert the tube so that the double bend is in a horizontal position. Wipe the acid from the capillary with disposable tissue several layers thick. Discard the tissue immediately to avoid burning the fingers. Reweigh to the nearest 0.0001 g and record the weight of the sample. Submerge the capillary of the tube in approximately 100 mL of water contained in the ~~400-mL~~ 400 mL beaker. Force the weighed sample from the tube by a stream of water from a wash bottle by placing the delivery tip in the exposed end of the snake tube (Note 4). Wash the tube with ~~50~~ 50 mL to 70 mL of water. Remove the tube and wash the outside free of acid. Swirl the contents of the beaker gently while washing. Accumulate all washings in the beaker and add 3 to 5 drops of phenolphthalein indicator solution. Record the temperature of the 0.5 meq/mL(N) NaOH solution, and then titrate the sample to a pink end point. Record the titration to the nearest 0.02 mL.

⁶ This reagent is also described in Practice E200.

NOTE 4—Do not introduce the water into the snake tube too rapidly, as this will cause spattering.

14. Calculation

14.1 If necessary, correct the buret reading for calibration errors and record the volume of titrant as V and the temperature as t .

14.2 Correct the normality of the sodium hydroxide standard solution for any difference in temperature between time of standardization and time of use according to the following equation:

$$N = N_s + 0.00014 (s - t) \quad (1)$$

where:

- N = normality meq/mL(N) of NaOH solution at temperature t during use,
- N_s = normality meq/mL(N) of NaOH solution at temperature s during standardization,
- s = temperature of NaOH solution during standardization, and
- t = temperature of NaOH solution during analysis.

14.3 Calculate the total acidity as % mass (m/m) of sulfuric acid as follows:

$$\text{Sulfuric acid, \% mass (m/m)} = \frac{(VN \times 0.04904)}{W} \times 100 \quad (2)$$

where:

- V = corrected millilitre of NaOH solution required for titration of the sample,
- N = meq/mL(N) normality of the NaOH solution, and
- W = grams of sample used.

15. Report

15.1 Report the % mass (m/m) of sulfuric acid to the nearest 0.01 % mass(m/m).

16. Precision and Bias

16.1 The following criteria should be used for judging the acceptability of results (see [Note 5](#)):

16.1.1 *Repeatability (Single Analyst)*—The standard deviation for a single determination has been estimated to be 0.069 % mass (m/m) absolute at 56 df. The 95 % limit for the difference between two such runs is 0.19 % mass (m/m) absolute.

16.1.2 *Laboratory Precision (Within-Laboratory, Between-Days Variability)*—The standard deviation of results (each the average of duplicates), obtained by the same analyst on different days, has been estimated to be 0.104 % mass (m/m) absolute at 28 df. The 95 % limit for the difference between two such averages is 0.29 % mass (m/m) absolute.

16.1.3 *Reproducibility (Multilaboratory)*—The standard deviation of results (each the average of duplicates), obtained by analysts in different laboratories, has been estimated to be 0.124 % mass (m/m) absolute at 7 df. The 95 % limit for the difference between two such averages is 0.35 % mass (m/m) absolute.

NOTE 5—These precision estimates are based on an interlaboratory study of analyses performed in 1963 on three samples containing approximately 80, 90, and 95 % mass (m/m) sulfuric acid. One analyst in each of ten laboratories performed duplicate determinations and repeated one day later, for a total of 120 determinations.⁷ Practice [E180](#) was used in developing these precision estimates.

16.2 Since there is no accepted reference material for determining the bias for measuring the total acidity of sulfuric acid, the bias of this test method has not been determined.

⁷ Supporting data have been filed at ASTM International Headquarters and may be obtained by requesting Research Report RR:E15-1047. Contact ASTM Customer Service at service@astm.org.

BAUMÉ GRAVITY

17. Scope

17.1 This test method covers the determination of the Baumé gravity of concentrated sulfuric acid by means of a glass hydrometer in the range from ~~57–57° Baumé~~ to 66.2° Baumé. The Baumé gravity is determined at ~~15.5°C (60°F); 15.5 °C (60 °F)~~. This test method is not applicable to readings above 66.2 Baumé gravity units.

18. Definition

18.1 *Baumé Gravity*—a unit of density based on specific gravity and defined by the following equation:

$$\text{Baumé gravity} = 145 - [145/\text{sp gr}] \text{ at } 15.5/15.5^{\circ}\text{C} (60/60^{\circ}\text{F}) \quad (3)$$

19. Summary of Test Method

19.1 A sample of sulfuric acid is placed in a hydrometer cylinder and when the temperature is constant, the Baumé gravity is read from the glass hydrometer.

20. Significance and Use

20.1 The Baumé gravity is used to classify various grades of sulfuric acid. This test method is not applicable for accurate determinations of the concentration of sulfuric acid.

21. Apparatus

21.1 *Hydrometer*,⁸streamline or torpedo design, precision grade for liquids heavier than water in ranges from ~~57–57° Bé~~ to 62° Bé and ~~63–63° Bé~~ to 67° Bé. The total length shall be approximately 305 mm (12 in.) divided to 0.05° Bé over a ~~152 mm (6 in.)~~ 152 mm (6 in.) (approximate) scale and standardized at ~~15.5/15.5°C (60/60°F); 15.5 °C (60 °F/60 °F)~~ with a tolerance of 0.05° Bé throughout. The modulus is as follows:

$$\text{Bé} = 145 - [145/\text{sp gr}] \text{ at } 15.5/15.5^{\circ}\text{C} (60/60^{\circ}\text{F}) \quad (4)$$

Each of the hydrometers shall show on the scale the modulus.

21.2 *Thermometer*, having a range ~~from –2 to +80°C (30 to 180°F)~~ from –2 °C to +80 °C (30 °F to 180 °F) and conforming to the requirements for Thermometer 15C (15F) as prescribed in Specification E1.

21.3 *Cylinder; Hydrometer*, glass, with or without lip, diameter ~~38~~38 mm to 40 mm, height ~~325~~325 mm to 375 mm.

22. Temperature of Test

22.1 Baumé gravity shall be determined at ~~15.5 ± 0.3°C (60 ± 0.5°F); 15.5 °C ± 0.3 °C (60 °F ± 0.5 °F)~~.

23. Procedure

23.1 Rinse a clean hydrometer cylinder with the sample to be tested, add the sample, and adjust the temperature to ~~15.5 ± 0.3°C (60 ± 0.5°F); 15.5 °C ± 0.3 °C (60 °F ± 0.5 °F)~~. Place the cylinder in a vertical position in a location free of air currents. Insert the hydrometer in the sample. Push it down about 3 mm below the level at which it will float and release it. Read the hydrometer when it has come to rest, floating freely, and the temperature is ~~15.5°C (60°F); 15.5 °C (60 °F)~~. The correct reading is that point on the hydrometer scale at which the surface of the liquid cuts the scale. Determine this point by placing the eye slightly below the level of the liquid and slowly raising it until the surface, first seen as a distorted ellipse, appears to become a straight line cutting the hydrometer scale. Record as Baumé gravity.

⁸ See Specification E100.

24. Calculation

24.1 Calculate the specific gravity for later calculations in accordance with the following equation:

$$\text{sp gr} = \frac{145}{145 - B\acute{e}} \quad (5)$$

25. Report

25.1 Report the Baumé gravity to the nearest 0.01 unit.

26. Precision and Bias

26.1 The following criteria should be used for judging the acceptability of results (see **Note 6**):

26.1.1 *Repeatability (Single Analyst)*—The standard deviation for a single determination has been estimated to be 0.018 unit absolute at 48 df. The 95 % limit for the difference between two such runs is 0.05 unit absolute.

26.1.2 *Laboratory Precision (Within-Laboratory, Between-Days Variability)*—The standard deviation of results (each the average of duplicates), obtained by the same analyst on different days, has been estimated to be 0.016 unit absolute at 24 df. The 95 % limit for the difference between two such averages is 0.045 unit absolute.

26.1.3 *Reproducibility (Multilaboratory)*—The standard deviation of results (each the average of duplicates), obtained by analysts in different laboratories, has been estimated to be 0.063 unit absolute at 7 df. The 95 % limit for the difference between two such averages is 0.18 unit absolute.

NOTE 6—These precision estimates are based on an interlaboratory study of analyses performed in 1963 on three samples having Baumé gravities of approximately 61, 65, and 66 units. One analyst in each of nine laboratories performed duplicate determinations and repeated one day later, for a total of 104 determinations.⁷ Practice **E180** was used in developing these precision estimates.

26.2 Since there is no accepted reference material for determining the bias for measuring the Baumé gravity of sulfuric acid, the bias of this test method has not been determined.

NONVOLATILE MATTER

27. Scope

27.1 This test method covers the gravimetric determination of nonvolatile matter in sulfuric acid. The lower limit of determination of nonvolatile matter is 0.001 % mass (m/m).

28. Summary of Test Method

28.1 A weighed sample of acid is evaporated, ignited, and the residue weighed.

29. Apparatus

29.1 *Evaporating Dish*, platinum or high-silica glass, ~~±50 mL~~ 150 mL.

29.2 *Muffle Furnace*, maintained at ~~800 ± 25°C (1472 ± 45°F)~~ 800 °C ± 25 °C (1472 °F ± 45 °F).

29.3 *Crucible Tongs*.

30. Procedure

30.1 Clean a platinum or a high-silica glass dish (**Note 7** and **Note 8**) and ignite in a muffle furnace at ~~800 ± 25°C (1472 ± 45°F)~~ 800 °C ± 25 °C (1472 °F ± 45 °F) for at least 10 min. Cool in a desiccator to room temperature and weigh the dish to the nearest 0.1 mg (**Note 9**).