

INTERNATIONAL  
STANDARD

**ISO**  
**5456-2**

First edition  
1996-06-15

---

---

**Technical drawings — Projection methods —**

**Part 2:**

Orthographic representations

iTeh Standards

(<https://standards.itih.ai>)

*Dessins techniques — Méthodes de projection —*

*Partie 2: Représentations orthographiques*

Document Preview

ISO 5456-2:1996

<https://standards.itih.ai/catalog/standards/iso/26ecbc6f-88d6-468b-bfa0-f86e1c7ff59b/iso-5456-2-1996>



Reference number  
ISO 5456-2:1996(E)

## Foreword

ISO (the International Organization for Standardization) is a worldwide federation of national standards bodies (ISO member bodies). The work of preparing International Standards is normally carried out through ISO technical committees. Each member body interested in a subject for which a technical committee has been established has the right to be represented on that committee. International organizations, governmental and non-governmental, in liaison with ISO, also take part in the work. ISO collaborates closely with the International Electrotechnical Commission (IEC) on all matters of electrotechnical standardization.

Draft International Standards adopted by the technical committees are circulated to the member bodies for voting. Publication as an International Standard requires approval by at least 75 % of the member bodies casting a vote.

International Standard ISO 5456-2 was prepared by Technical Committee ISO/TC 10, *Technical drawings, product definition and related documentation*, Subcommittee SC 1, *Basic conventions*.

ISO 5456 consists of the following parts, under the general title *Technical drawings — Projection methods*:

- *Part 1: Synopsis*
- *Part 2: Orthographic representations*
- *Part 3: Axonometric representations*
- *Part 4: Central projection*

Annex A forms an integral part of this part of ISO 5456.

© ISO 1996

All rights reserved. Unless otherwise specified, no part of this publication may be reproduced or utilized in any form or by any means, electronic or mechanical, including photocopying and microfilm, without permission in writing from the publisher.

International Organization for Standardization  
Case postale 56 • CH-1211 Genève 20 • Switzerland

Printed in Switzerland

## Introduction

Orthographic representation in its various forms is the most widely used method of representing technical objects in all fields of technical drawing (mechanical, electrical, construction, etc.), and is thus considered to be the accepted technical language.

**iTeh Standards**  
**(<https://standards.iteh.ai>)**  
**Document Preview**

[ISO 5456-2:1996](https://standards.iteh.ai/catalog/standards/iso/26ecbc6f-88d6-468b-bfa0-f86e1c7ff59b/iso-5456-2-1996)

<https://standards.iteh.ai/catalog/standards/iso/26ecbc6f-88d6-468b-bfa0-f86e1c7ff59b/iso-5456-2-1996>

This page intentionally left blank

**iteh Standards**  
**(<https://standards.iteh.ai>)**  
**Document Preview**

[ISO 5456-2:1996](https://standards.iteh.ai/catalog/standards/iso/26ecbc6f-88d6-468b-bfa0-f86e1c7ff59b/iso-5456-2-1996)

<https://standards.iteh.ai/catalog/standards/iso/26ecbc6f-88d6-468b-bfa0-f86e1c7ff59b/iso-5456-2-1996>

# Technical drawings — Projection methods —

## Part 2: Orthographic representations

iTeh Standards  
(<https://standards.iteh.ai>)  
Document Preview

### 1 Scope

This part of ISO 5456 specifies basic rules for the application of orthographic representation to all types of technical drawings in all technical fields, according to the general rules specified in ISO 128, ISO 129, ISO 3098-1, ISO 3461-2 and ISO 5456-1.

### 2 Normative references

The following standards contain provisions which, through reference in this text, constitute provisions of this part of ISO 5456. At the time of publication, the editions indicated were valid. All standards are subject to revision, and parties to agreements based on this part of ISO 5456 are encouraged to investigate the possibility of applying the most recent editions of the standards indicated below. Members of IEC and ISO maintain registers of currently valid International Standards.

ISO 128:1982, *Technical drawings — General principles of presentation*.

ISO 129:1985, *Technical drawings — Dimensioning — General principles, definitions, methods of execution and special indications*.

ISO 3098-1:1974, *Technical drawings — Lettering — Part 1: Currently used characters*.

ISO 3461-2:1987, *General principles for the creation of graphical symbols — Part 2: Graphical symbols for use in technical product documentation*.

ISO 5456-1:1996, *Technical drawings — Projection methods — Part 1: Synopsis*.

ISO 10209-1:1992, *Technical product documentation — Vocabulary — Part 1: Terms relating to technical drawings: general and types of drawings*.

ISO 10209-2:1993, *Technical product documentation — Vocabulary — Part 2: Terms relating to projection methods*.

### 3 Definitions

For the purposes of this part of ISO 5456, the definitions given in ISO 5456-1, ISO 10209-1 and ISO 10209-2 apply.

## 4 General principles

### 4.1 General

Orthographic representation is obtained by means of parallel orthogonal projections and results in flat, two-dimensional views systematically positioned relative to each other. To show an object completely, the six views in the directions a, b, c, d, e and f may be necessary, in order of priority (see figure 1 and table 1).

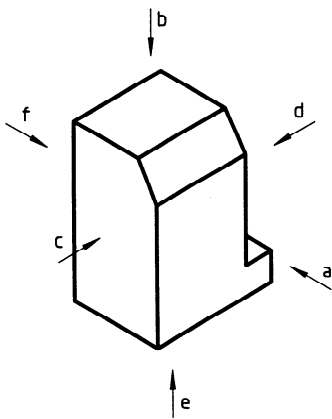

Figure 1

### 4.2 Designation of views

See table 1.

Table 1

Direction of observation		Designation of view
View in direction	View from	
a	the front	A
b	above	B (E) <sup>1)</sup>
c	the left	C
d	the right	D
e	below	E
f	the rear	F

1) See 5.4.

The most informative view of the object to be represented is normally chosen as the principal view

(front view). This is view A according to the direction of viewing a (see figure 1 and table 1), generally showing the object in the functioning or manufacturing or mounting position. The position of other views relative to the principal view in the drawing depends on the projection method chosen (first angle, third angle, reference arrows). In practice, not all six views (A to F) are needed. When views (cuts or sections) other than the principal view are necessary, these shall be selected in order to:

- limit the number of views, cuts and sections to the minimum necessary and sufficient to fully represent the object without ambiguity;
- avoid unnecessary repetition of detail.

## 5 Methods of representation

### 5.1 First angle projection

The first angle projection method is an orthographic representation in which the object to be represented (see figure 1) appears between the observer and the coordinate planes on which the object is orthogonally projected (see figure 2).

The positions of the various views relative to the principal (front) view A are determined by rotating their projection planes around lines coinciding with or parallel to the coordinate axes on the coordinate plane (drawing surface) on which the front view A is projected (see figure 2).

Therefore, in the drawing, with reference to the principal view A, the other views are arranged as follows (see figure 3):

- View B: the view from above is placed underneath;
- View E: the view from below is placed above;
- View C: the view from left is placed on the right;
- View D: the view from the right is placed on the left;
- View F: the view from the rear is placed on the right or on the left, as convenient.

The identifying graphical symbol of this method is shown in figure 4.