



Designation: B897 – 23

# Standard Specification for Configuration of Zinc and Zinc Alloy Jumbo, Block, Half Block, and Slab Ingot<sup>1</sup>

This standard is issued under the fixed designation B897; the number immediately following the designation indicates the year of original adoption or, in the case of revision, the year of last revision. A number in parentheses indicates the year of last reapproval. A superscript epsilon ( $\epsilon$ ) indicates an editorial change since the last revision or reapproval.

## 1. Scope

1.1 This specification covers zinc and zinc alloy jumbo, block, half block, and slab ingot meeting dimensional requirements.

1.2 The values stated in inch-pound units are to be regarded as standard. The values given in parentheses are mathematical conversions to SI units that are provided for information only and are not considered standard.

1.3 *This standard does not purport to address all of the safety concerns, if any, associated with its use. It is the responsibility of the user of this standard to become familiar with all hazards including those identified in the appropriate Safety Data Sheet (SDS) for this product/material as provided by the manufacturer, to establish appropriate safety, health, and environmental practices, and determine the applicability of regulatory limitations prior to use.*

1.4 *This international standard was developed in accordance with internationally recognized principles on standardization established in the Decision on Principles for the Development of International Standards, Guides and Recommendations issued by the World Trade Organization Technical Barriers to Trade (TBT) Committee.*

## 2. Referenced Documents

2.1 The following standards of the issue in effect on date of order acceptance, form a part of this specification to the extent referenced herein:

2.2 *ASTM Standards:*<sup>2</sup>

**B899 Terminology Relating to Non-ferrous Metals and Alloys**

**B949 Specification for General Requirements for Zinc and Zinc Alloy Products**

<sup>1</sup> This specification is under the jurisdiction of ASTM Committee B02 on Nonferrous Metals and Alloys and is the direct responsibility of Subcommittee B02.04 on Zinc and Cadmium.

Current edition approved April 1, 2023. Published April 2023. Originally approved in 1999. Last previous edition approved in 2018 as B897 – 18. DOI: 10.1520/B0897-23.

<sup>2</sup> For referenced ASTM standards, visit the ASTM website, www.astm.org, or contact ASTM Customer Service at service@astm.org. For *Annual Book of ASTM Standards* volume information, refer to the standard's Document Summary page on the ASTM website.

## 3. Terminology

3.1 Terms shall be defined in accordance with Terminology B899.

3.2 *Definitions of Terms Specific to This Standard:*

3.2.1 *jumbo ingot, n*—large casting of zinc or zinc alloy, having through holes for chains, designed for handling by mechanical equipment, with a nominal weight of 2400 lb, which is also referred to as a jumbo or strip jumbo.

3.2.2 *block ingot, n*—large casting of zinc or zinc alloy, having lift pockets, designed for handling by mechanical equipment, with a nominal weight of 2400 lb, which is also referred to as a block.

3.2.3 *half block ingot, n*—large casting of zinc or zinc alloy, having lift pockets, designed for handling by mechanical equipment, with a nominal weight of 1200 lb, which is also referred to as half block.

3.2.4 *slab ingot, n*—smaller casting of zinc or zinc alloy designed for manual handling, but often handled by mechanical equipment, with a nominal weight of 55 lb, which is also referred to as slab.

3.2.5 *slab bundle, n*—arrangement of typically 40 slab ingots strapped with metal or other binding, with nominal weight of 2200 lb, which is also referred to as bundle. The bundle may be stacked on a wood or other skid.

## 4. Ordering Information

4.1 Orders for jumbo, block, half block, or slab ingots under this specification shall include the following information in addition to the appropriate information specified in Specification B949, Section 4:

4.1.1 Type of ingot (Jumbo, Type 1 Block, Type 2 Block, Half Block Type 1, Half Block Type 2, or Slab).

4.1.2 Order may stipulate dimensions, or tolerances, or both, not meeting this specification only upon mutual written agreement between purchaser and producer.

## 5. Materials and Manufacture

5.1 The producer shall use care to have each lot of zinc metal or zinc alloy jumbo, block, half block, or slab ingots be of as uniform quality as possible.

**TABLE 1 Zinc Jumbo Ingot Specification**

Weight 2400 lb ± 100 lb (1089 kg ± 45 kg) Table of Dimensions					
Drawing Identification Letter	Dimension Definition	Dimension, in.		Dimension, mm	
		min	max	min	max
A	Top length	48.75	50.25	1238	1276
B	Bottom overall length <sup>A</sup>	46.00	48.00	1168	1219
C	Top width	19.25	20.25	489	514
0.5C	Center of pin hole to length edge	9.63	10.13	245	257
D	Bottom overall width <sup>A</sup>	16.50	18.50	419	470
E	Height <sup>B</sup>	11.75	13.25	298	337
F	Center of pin hole to end edge	5.75	6.75	146	171
G	Height of side fork slots	3.00	4.00	76	102
J	Upper width of side fork slot	5.50	8.00	140	203
K	Lower width of side fork slot	8.00	10.50	203	267
L	Top pin hole diameter	3.00	5.00	76	127
M	Bottom pin hole diameter <sup>B</sup>	4.50	6.50	114	165
N	Bottom center leg width	11.50	15.25	292	387
P	Upper width of end fork slot <sup>B,C</sup>	5.50	8.00	140	203
R	Lower width of end fork slot <sup>C</sup>	7.50	10.00	191	254
S	Lower outer leg(s) length	6.50	8.00	165	203
T	Height of end fork slot	3.00	4.00	76	102

<sup>A</sup> Dimensions with curved corners are measured by placing straight edges on both sides of the curve and using the intersecting point for the reference measurement.

<sup>B</sup> Minimum *P* dimension must be greater than the *M* dimension maximum.

<sup>C</sup> Minimum *R* dimension must be greater than the *P* dimension maximum.

**TABLE 2 Zinc Block Ingot Specification**

Weight 2400 lb ± 100 lb (1089 kg ± 45 kg) Table of Dimensions					
Drawing Identification Letter	Dimension Definition	Dimension, in.		Dimension, mm	
		min	max	min	max
A	Top length	29.50	33.00	749	838
E	Bottom length	23.00	30.25	584	768
G	Top width	19.25	23.00	489	584
H	Bottom width	14.00	19.25	356	489
F	Height	18.50	23.50	470	597
C	Lower width of side fork slot	14.75	20.00	375	508
D	Lower leg length	2.25	4.25	57	108
B	Distance between lift pockets	21.75	28.25	552	718
J	Bottom fork slot height	2.50	3.50	64	89
N	Inside lift pocket width	3.50	6.50	89	165
P	Outside lift pocket width	4.00	8.50	102	216
K	Ingot end to lift pocket	0.00	3.25	0	83
M	Lift pocket depth	1.25	2.75	32	70
R	Ingot top to lift pocket	1.75	7.00	45	178

## 6. Dimensions, Mass, and Permissible Variations

### 6.1 Jumbo Ingots:

6.1.1 Permissible variations in dimensions and tolerances for zinc or zinc alloy jumbo ingots shall be within the limits specified in **Table 1** and **Fig. 1** unless prior written agreement exists between purchaser and producer for nonstandard dimensions and tolerances.

6.1.2 Jumbo ingot weight shall be 2400 lb ± 100 lb (1089 kg ± 45 kg).

### 6.2 Block Ingots:

6.2.1 Permissible variations in dimensions and tolerances for zinc or zinc alloy block ingot shall be within the limits specified in **Table 2** and **Fig. 2** and **Fig. 3** unless prior written agreement exists between the purchaser and producer for nonstandard dimensions and tolerances.

**TABLE 3 Zinc Half Block Ingot Specification**

Weight 1200 lb ± 50 lb (545 kg ± 23 kg) Table of Dimensions					
Drawing Identification Letter	Dimension Definition	Dimension, in.		Dimension, mm	
		min	max	min	max
A	Top length	29.50	33.00	749	838
E	Bottom length	24.50	31.50	622	800
G	Top width	19.25	23.00	489	584
H	Bottom width	16.50	21.50	419	546
F	Height	11.00	14.00	279	355
C	Lower width of side fork slot	14.75	20.00	375	508
D	Lower leg length	2.25	4.25	57	108
B	Distance between lift pockets	19.50	28.25	495	718
J	Bottom fork slot height	2.50	3.50	64	89
N	Inside lift pocket width	3.00	6.50	76	165
P	Outside lift pocket width	4.00	8.50	102	216
K	Ingot end to lift pocket	0.00	3.25	0	83
M	Lift pocket depth	1.25	2.75	32	70
R	Ingot top to lift pocket	1.75	7.00	45	178
Q	NA Lift pocket can go to the bottom of ingot				

**TABLE 4 Zinc Slab Ingot and Bundle Specification**

Slab Weight 55 lb ± 10 lb (25 kg ± 5 kg) Bundle Weight 2200 lb ± 220 lb (1000 kg ± 100 kg) Table of Dimensions					
Drawing Identification Letter	Dimension Definition	Dimension, in.		Dimension, mm	
		min	max	min	max
A	Main slab height	1.3	2.4	35	61
B	Main slab bottom width	6.6	8.7	170	221
C	Main slab top width	7.5	9.8	193	249
D	Main slab bottom length	14.0	18.0	358	458
E	Main slab top length	15.8	19.7	403	501
F	Foot slab height	3.1	4.7	81	120
G	Foot slab top width	8.9	11.0	228	280
H	Foot slab bottom overall width	5.4	10.5	139	267
I	Foot slab top length	16.9	19.7	431	501
J	Foot slab bottom overall length	14.9	16.4	381	417
K	Slab bundle overall height	16.8	30.0	429	762
L	Slab bundle overall width	15.9	20.0	406	508
M	Slab bundle overall length	32.0	39.4	815	1001
N	Fork slot height	1.9	4.3	50	110

6.2.2 In addition to lift pockets in block ingots employed for ingot handling, smaller lift pockets are sometimes located on the ingot sides or ends and are employed to remove the ingot from the ingot mold during production and may be present at the discretion of the producer.

6.2.3 Block ingot weight shall be 2400 lb ± 100 lb (1089 kg ± 45 kg).

6.3 Smaller “half height” half block ingots typically weighing 1200 lb (545 kg) are commonly used for casting and master alloy ingots.

6.3.1 Permissible variations in dimensions and tolerances for zinc or zinc alloy half block ingot shall be within the limits specified in **Table 3** and **Fig. 2** and **Fig. 3** unless prior written agreement exists between the purchaser and producer for nonstandard dimensions and tolerances.

6.3.2 In addition to lift pockets in block ingots employed for ingot handling, smaller lift pockets are sometimes located on the ingot sides or ends and are employed to remove the ingot

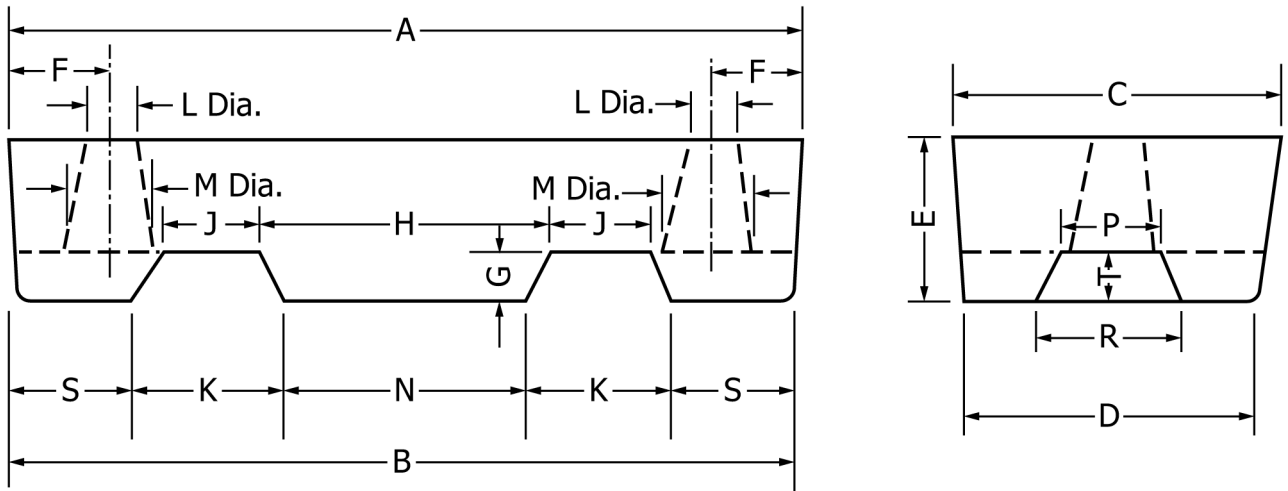

FIG. 1 Zinc Jumbo Ingot

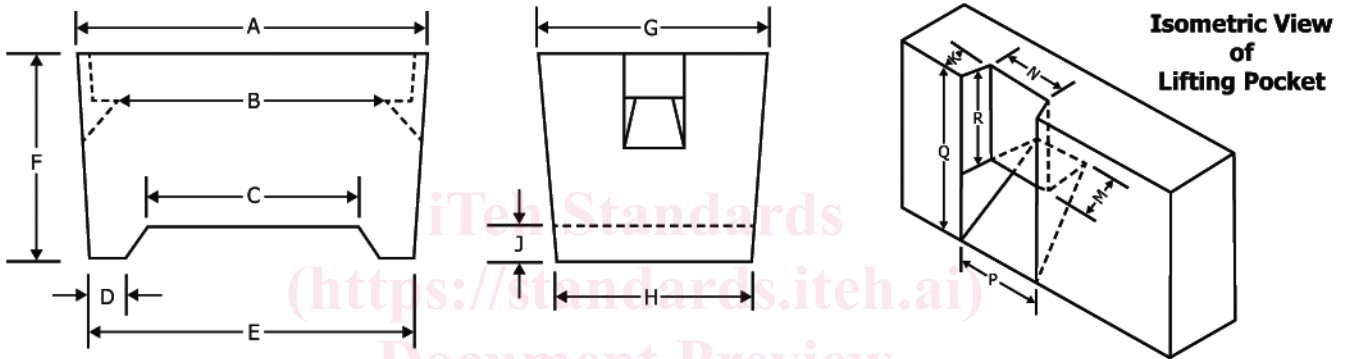

FIG. 2 Type 1 Block Ingot

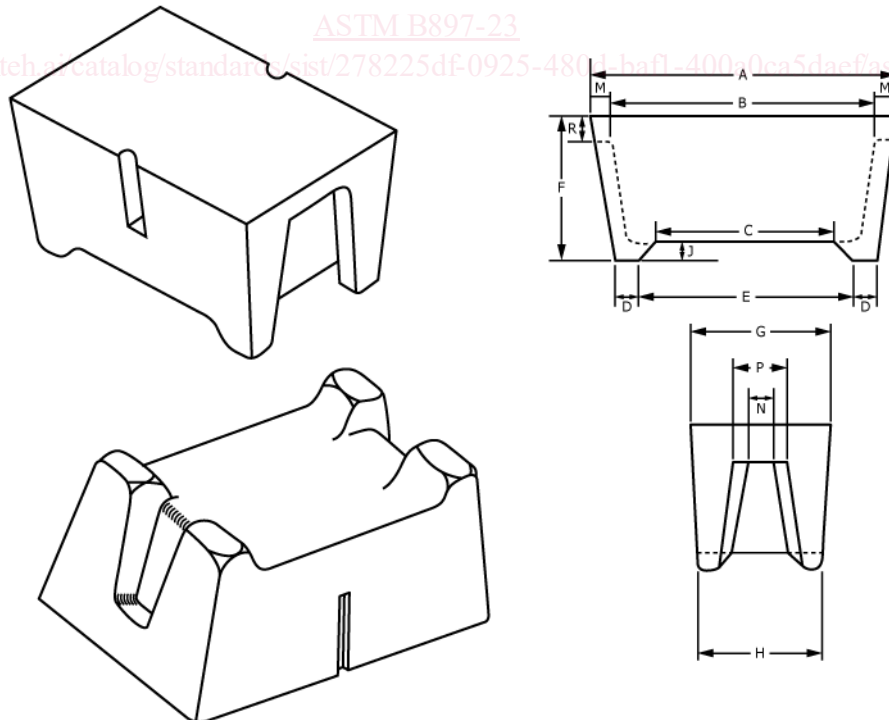

FIG. 3 Type 2 Block Ingot