

# INTERNATIONAL STANDARD

**ISO**  
**5456-4**

First edition  
1996-06-15

---

---

## Technical drawings — Projection methods —

### Part 4: Central projection

iTeh Standards  
(<https://standards.itih.ai>)  
*Dessins techniques — Méthodes de projection —  
Partie 4: Projection centrale*  
Document Preview

[ISO 5456-4:1996](https://standards.itih.ai/catalog/standards/iso/24ce4351-a303-4f22-9dbc-f41433602d6c/iso-5456-4-1996)

<https://standards.itih.ai/catalog/standards/iso/24ce4351-a303-4f22-9dbc-f41433602d6c/iso-5456-4-1996>



Reference number  
ISO 5456-4:1996(E)

## Foreword

ISO (the International Organization for Standardization) is a worldwide federation of national standards bodies (ISO member bodies). The work of preparing International Standards is normally carried out through ISO technical committees. Each member body interested in a subject for which a technical committee has been established has the right to be represented on that committee. International organizations, governmental and non-governmental, in liaison with ISO, also take part in the work. ISO collaborates closely with the International Electrotechnical Commission (IEC) on all matters of electrotechnical standardization.

Draft International Standards adopted by the technical committees are circulated to the member bodies for voting. Publication as an International Standard requires approval by at least 75 % of the member bodies casting a vote.

International Standard ISO 5456-4 was prepared by Technical Committee ISO/TC 10, *Technical drawings, product definition and related documentation*, Subcommittee SC 1, *Basic conventions*.

ISO 5456 consists of the following parts, under the general title *Technical drawings — Projection methods*:

- Part 1: *Synopsis*
- Part 2: *Orthographic representations*
- Part 3: *Axonometric representations*
- Part 4: *Central projection*

Annexes A and B of this part of ISO 5456 are for information only.

© ISO 1996

All rights reserved. Unless otherwise specified, no part of this publication may be reproduced or utilized in any form or by any means, electronic or mechanical, including photocopying and microfilm, without permission in writing from the publisher.

International Organization for Standardization  
Case postale 56 • CH-1211 Genève 20 • Switzerland

Printed in Switzerland

## Introduction

Central projection (perspective) is a realistic pictorial representation obtained by projecting the object to be represented from a point at finite distance (projection centre) on a single projection plane (normally the drawing surface). Central projection provides excellent visual appearance of the object (monocular vision) and is often used in architectural drawings.

**iTeh Standards**  
**(<https://standards.itih.ai>)**  
**Document Preview**

[ISO 5456-4:1996](https://standards.itih.ai/catalog/standards/iso/24ce4351-a303-4f22-9dbc-f41433602d6c/iso-5456-4-1996)

<https://standards.itih.ai/catalog/standards/iso/24ce4351-a303-4f22-9dbc-f41433602d6c/iso-5456-4-1996>

This page intentionally left blank

**iteh Standards**  
**(<https://standards.iteh.ai>)**  
**Document Preview**

[ISO 5456-4:1996](#)

<https://standards.iteh.ai/catalog/standards/iso/24ce4351-a303-4f22-9dbc-f41433602d6c/iso-5456-4-1996>

# Technical drawings — Projection methods —

## Part 4: Central projection

iTeh Standards  
(<https://standards.itih.ai>)  
Document Preview

### 1 Scope

This part of ISO 5456 specifies basic rules for the development and application of central projection in technical drawings.

### 2 Normative reference

The following standard contains provisions which, through reference in this text, constitute provisions of this part of ISO 5456. At the time of publication, the edition indicated was valid. All standards are subject to revision, and parties to agreements based on this part of ISO 5456 are encouraged to investigate the possibility of applying the most recent edition of the standard indicated below. Members of IEC and ISO maintain registers of currently valid International Standards.

ISO 10209-2:1993, *Technical product documentation — Vocabulary — Part 2: Terms relating to projection methods*.

### 3 Definitions

For the purposes of this part of ISO 5456, the definitions given in ISO 10209-2 and the following definitions apply.

**3.1 alignment line:** Line parallel to a given line passing through the projection centre. Its intersection with the projection plane gives the vanishing point of all lines parallel to the given line.

**3.2 height of projection:** Vertical distance of the projection centre from the basic plane.

**3.3 horizontal distance:** Distance between the projection centre and the projection plane.

**3.4 projection angle:** Angle formed by the projection plane and the horizon plane.

**3.5 scale point:** Vanishing point of the horizontal direction orthogonal to that bisecting the angle formed by the horizon line and the alignment line of the given horizontal line, and allowing the true length of the projection of the given line to be determined.

**3.6 station of observation:** Orthogonal projection of the projection centre onto the basic plane.

## 4 Symbols

Letter symbols for terms used in central projection are given in table 1 and illustrated in figures 1 and 2, as well as in the figures mentioned in table 1.

**Table 1 — Letter symbols**

No.	Term	Letter symbol	Figure
1)	Projection plane	T	1
1)	Basic plane	G	1
1)	Basic line	X	1
3.4	Projection angle	$\beta$	5
1)	Horizon plane	HT	1
1)	Horizon line	h	1
3.1	Alignment line	VI	4
1)	Main point	C	1
1)	Vanishing point	V	4
1)	Main projector	pL	1
1)	Projection centre	O	1
3.2	Height of projection	H	1
3.3	Horizontal distance	d	1
1)	Vision cone	K	2
1)	Circle of vision	Ks	3
1)	Vision angle	$\alpha$	2
1)	Projector	PI	3
1)	Distance point	DP	15
3.5	Scale point	MP	16
3.6	Station of observation	Sp	1

1) Terms already defined in ISO 10209-2.

plane retain their direction in this representation (horizontal lines remain horizontal and vertical lines remain vertical). All lines perpendicular to the projection plane converge at the vanishing point, V, coinciding with the main point, C, (see figure 3 and 7.2.1 and 7.3).

## 5.2 Two-point perspective

A two-point perspective is a central projection of an object having its vertical outlines and edges parallel to the projection plane (particular position). All horizontal lines of a representation converge at the relative vanishing point on the horizon line (see figure 4 and 7.2.2 and 7.4).

## 5.3 Three-point perspective

A three-point perspective is a central projection of an object having no outlines or edges parallel to the projection plane (any position). If the projection plane is inclined towards the projection centre, i.e.  $\beta > 90^\circ$ , the vanishing point for vertical lines is situated below the horizon line (see figure 5 and 7.5.1 and 7.5.2).

## 5.4 Coordinate method

Representation by the coordinate method is based on simple proportions.

The coordinates, related to the main projector of all relevant points of the object to be represented, are taken by the graphic method from the basic plane and elevation. From these point coordinates, the image coordinates are obtained by a calculation method and entered to scale. The image points are connected to each other to provide a clear representation of the object (see figure 6).

## 5 Central projection methods

The mode of the central projection depends on the position of the object to be represented with respect to the projection plane.

### 5.1 One-point perspective

A one-point perspective is a central projection of an object having its principal face parallel to the projection plane (special position). All parallel outlines and edges of the object which are parallel to the projection

## 6 Principle

### 6.1 Location and position of the projection plane

The image size of an object can be varied by parallel shifting of the projection plane. If the object is placed in front of the projection plane, the representation will be enlarged. The object behind the projection plane will result in a smaller image. Figure 7 shows the

change in image size depending on the position of the object with respect to the projection plane.

Figure 8 shows the change in image size depending on the method of representation with vertical or inclined projection planes.

### 6.2 Two-point projection method

The two-point projection method is a central projection of an object having its vertical outlines and edges parallel to the projection plane. All horizontal lines of a representation converge at the relative vanishing point on the horizon line (see figure 9).

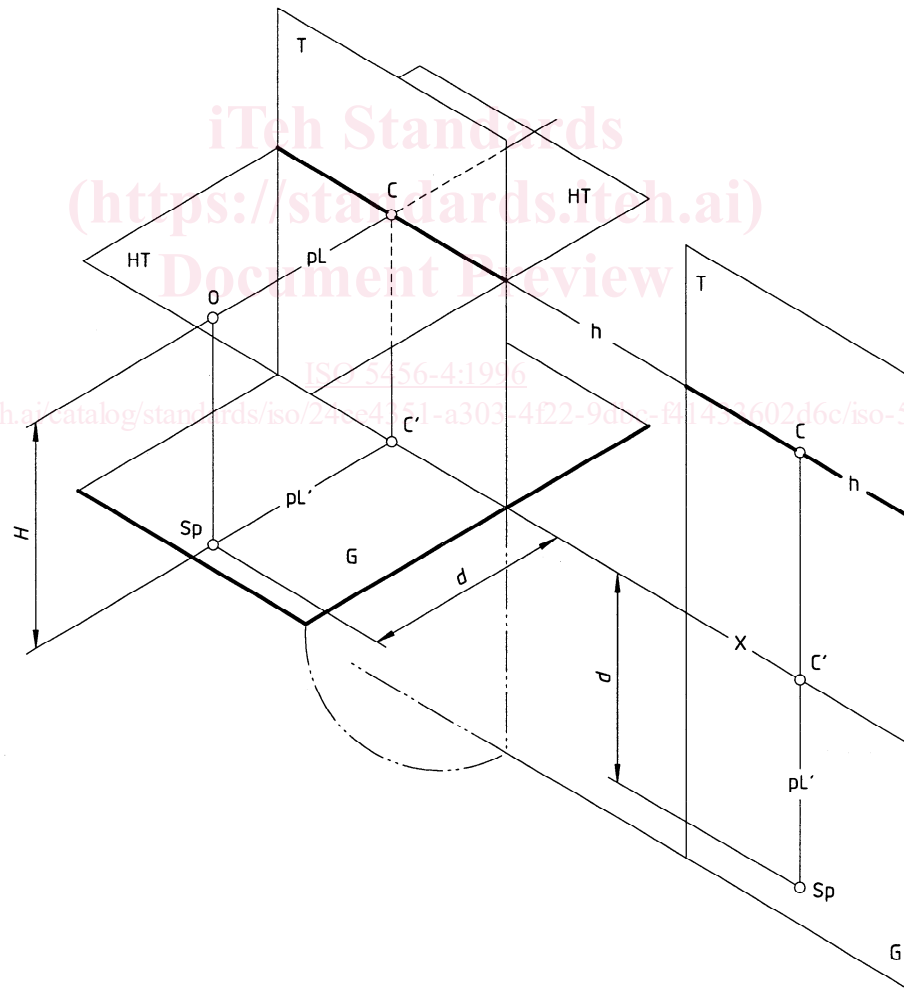

Figure 1 — Projection model of the central projection

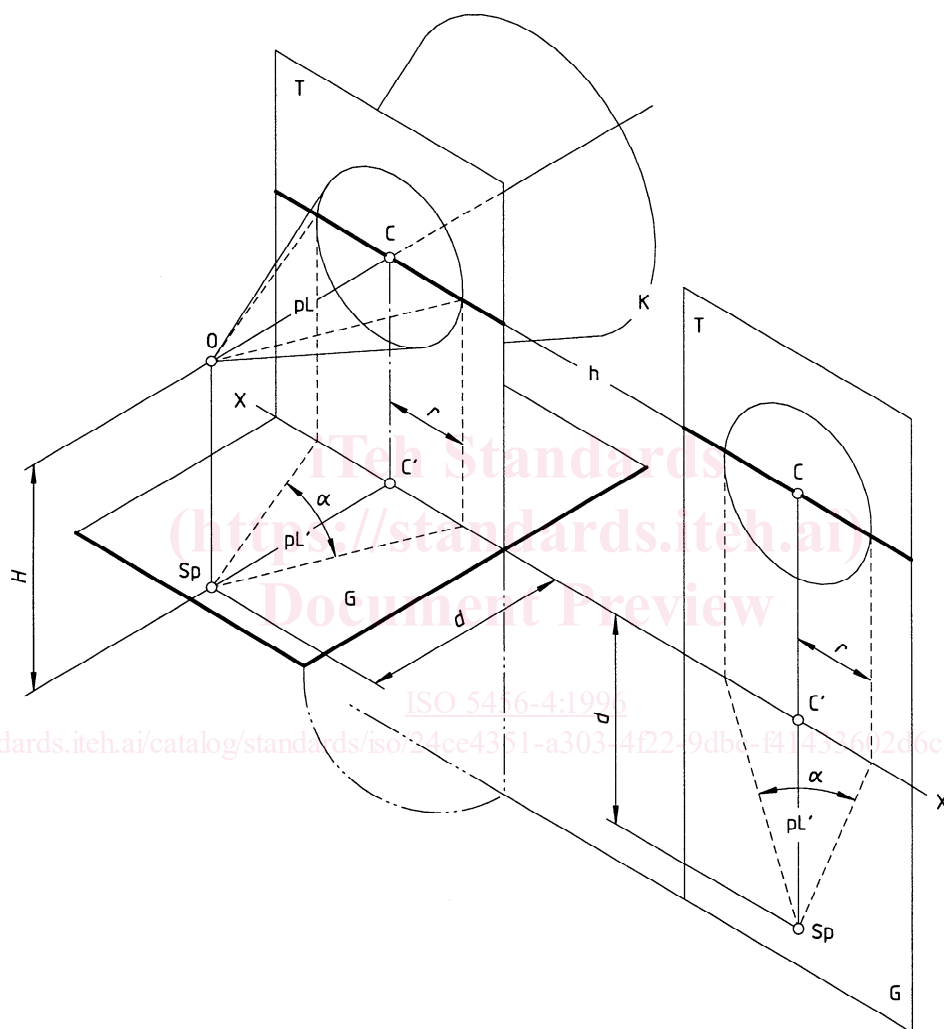

Figure 2 — Vision cone and vision angle in the projection model of the central projection



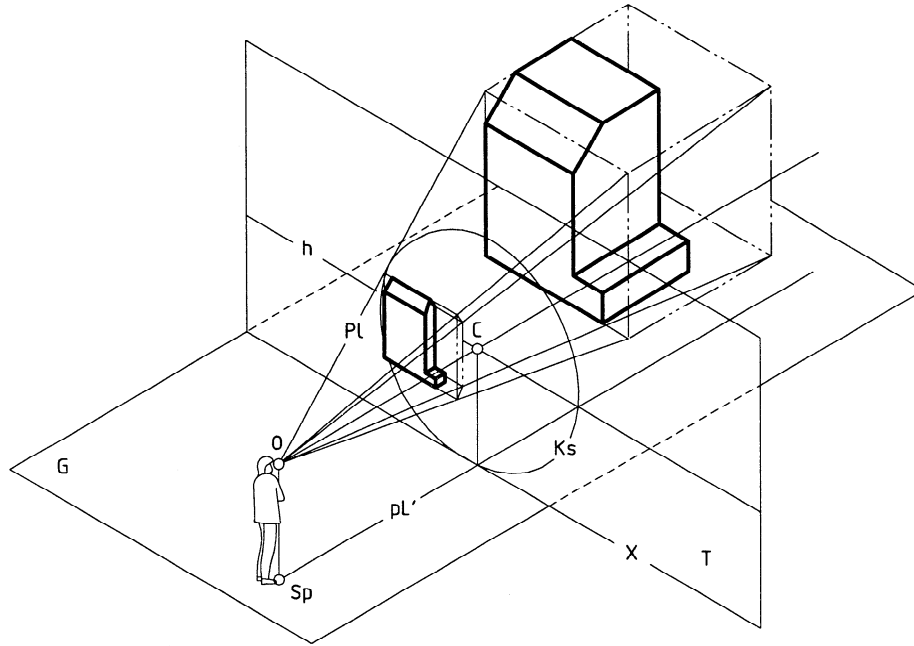

Figure 3 — Projection model with vertical projection plane and an object in a special position with respect to the projection plane

iTeh Standards  
 (https://standards.itih.ai)  
 Document Preview

ISO 5456-4:1996  
<https://standards.itih.ai/catalog/standards-iso/24ce4351-a303-4f70-bc-f11431002d6c/iso-5456-4-1996>

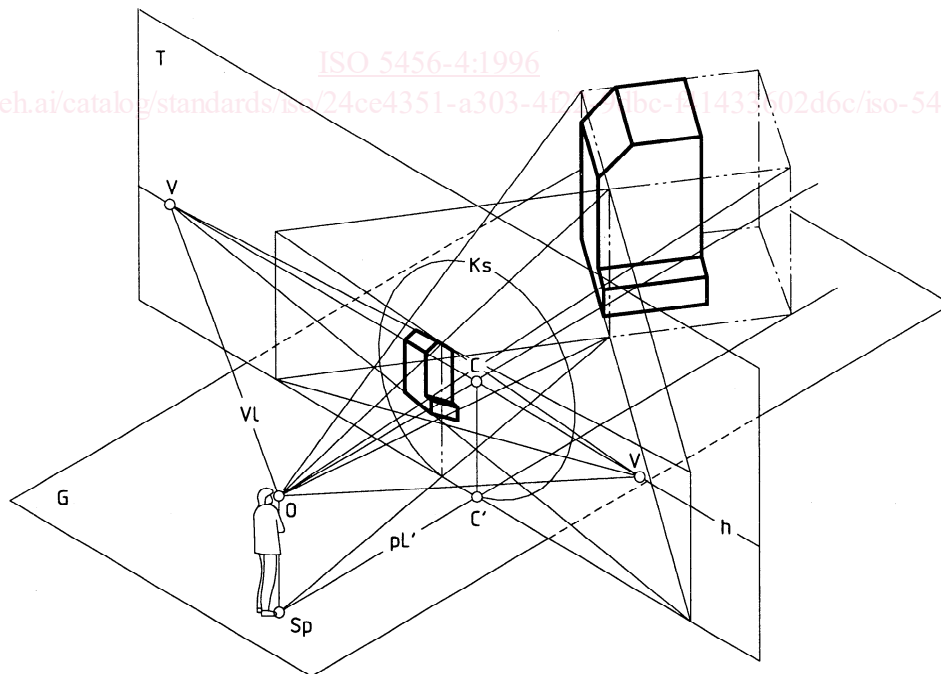
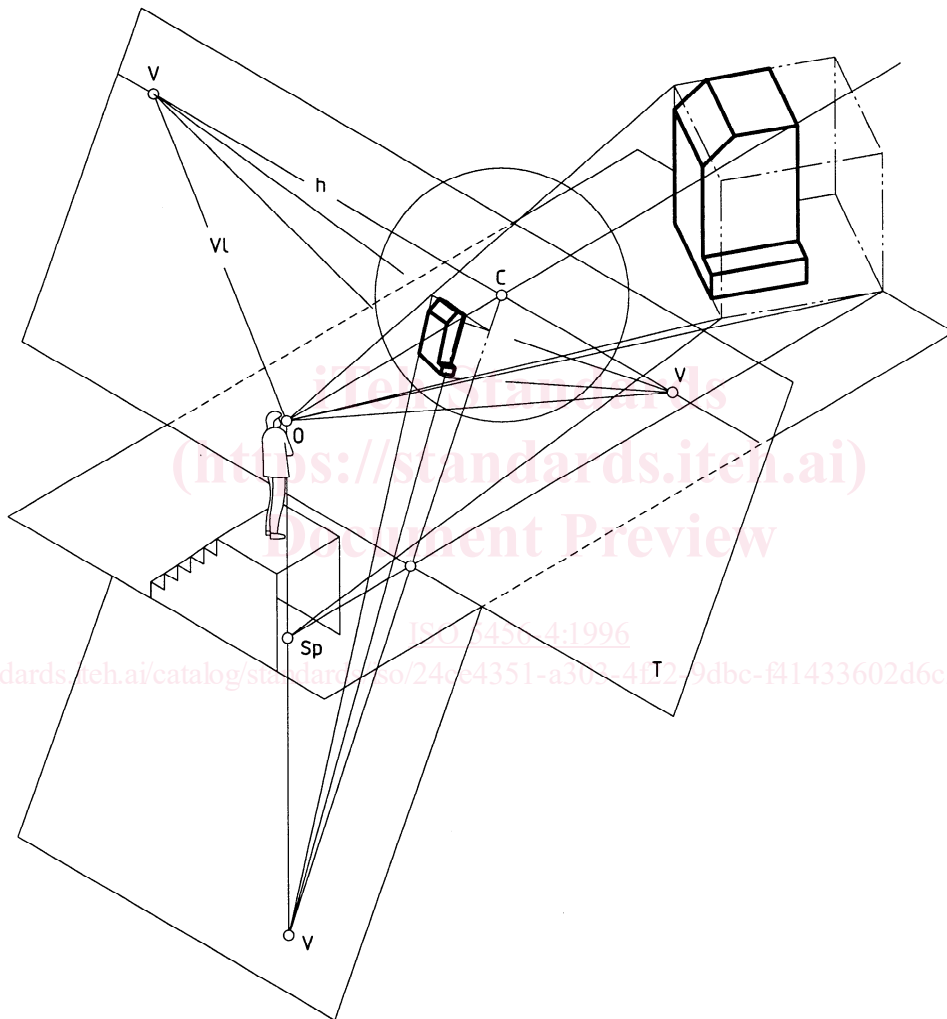

Figure 4 — Projection model with vertical projection plane and an object in a particular position with respect to the projection plane



**Figure 5 — Projection model with inclined projection plane and an object in any position with respect to the projection plane ( $\beta > 90^\circ$ )**



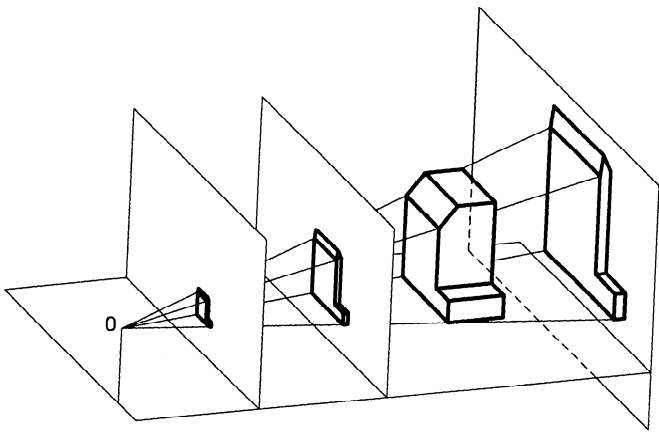

Figure 7 — Location of projection planes

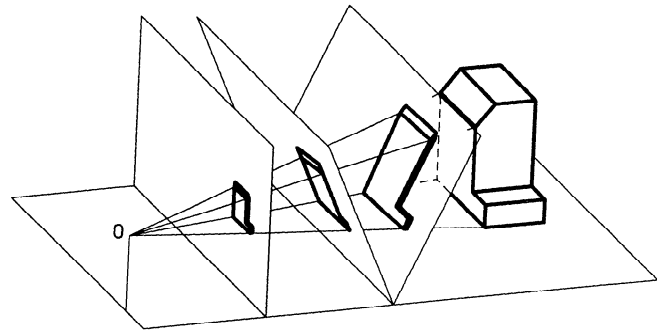

Figure 8 — Position of projection planes

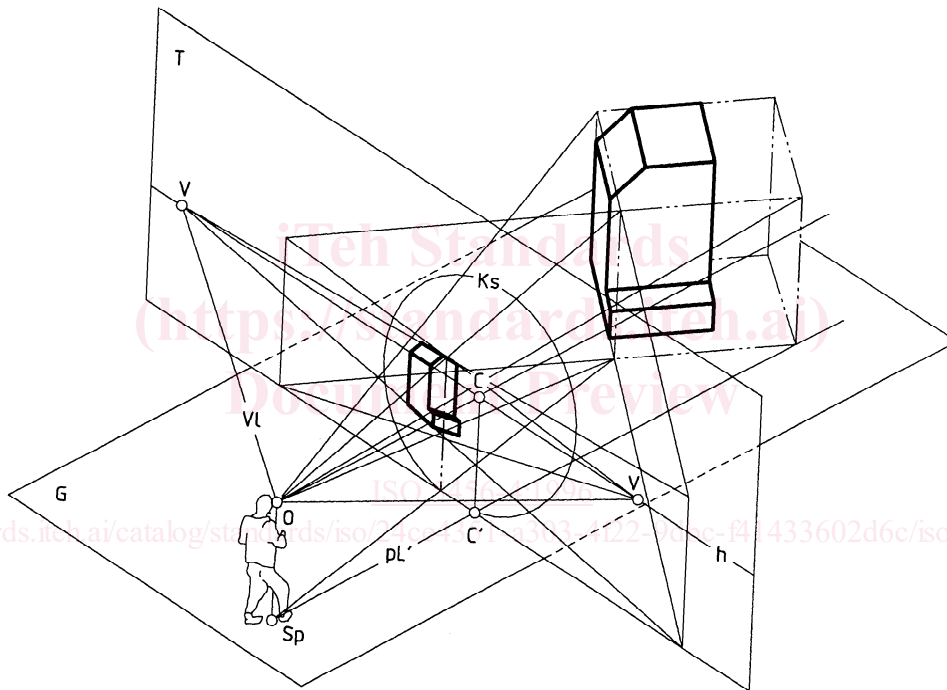

Figure 9 — Projection model with vertical projection plane and an object in any position with respect to the projection plane