



Designation: **F1276–99 (Reapproved 2016) F1276 – 23**

Standard Test Method for Creep Relaxation of Laminated Composite Gasket Materials¹

This standard is issued under the fixed designation F1276; the number immediately following the designation indicates the year of original adoption or, in the case of revision, the year of last revision. A number in parentheses indicates the year of last reapproval. A superscript epsilon (ϵ) indicates an editorial change since the last revision or reapproval.

1. Scope

1.1 This test method provides a means of measuring the amount of creep relaxation of a laminated composite gasket material at a predetermined time after a compressive stress has been applied.

1.2 Creep relaxation is measured by means of a calibrated bolt with dial indicator.

1.3 The values stated in SI units are to be regarded as the standard. The values given in parentheses are for information only.

1.4 *This standard does not purport to address all of the safety concerns, if any, associated with its use. It is the responsibility of the user of this standard to establish appropriate safety and health practices and determine the applicability of regulatory limitations prior to use.*

1.5 *This international standard was developed in accordance with internationally recognized principles on standardization established in the Decision on Principles for the Development of International Standards, Guides and Recommendations issued by the World Trade Organization Technical Barriers to Trade (TBT) Committee.*

2. Referenced Documents

2.1 ASTM Standards:²

[A193/A193M Specification for Alloy-Steel and Stainless Steel Bolting for High Temperature or High Pressure Service and Other Special Purpose Applications](#)

[B637 Specification for Precipitation-Hardening and Cold Worked Nickel Alloy Bars, Forgings, and Forging Stock for Moderate or High Temperature Service](#)

[E691 Practice for Conducting an Interlaboratory Study to Determine the Precision of a Test Method](#)

[F38 Test Methods for Creep Relaxation of a Gasket Material](#)

[F104 Classification System for Nonmetallic Gasket Materials](#)

[F436 Specification for Hardened Steel Washers \(Metric\) F0436_F0436M](#)

[F868 Classification for Laminated Composite Gasket Materials](#)

2.2 ASTM Adjuncts:

Relaxometer, Method B (Adjunct to Test Method [F38](#))³

3. Summary of Test Method

3.1 In this test method, the specimen is subjected to a compressive stress between two platens, with the stress applied by a nut

¹ This test method is under the jurisdiction of ASTM Committee [F03](#) on Gaskets and is the direct responsibility of Subcommittee [F03.20](#) on Mechanical Test Methods. Current edition approved Oct. 1, 2016/April 1, 2023. Published October 2016/May 2023. Originally approved in 1990. Last previous edition approved in 2009/2016 as F1276 – 99 (2009) (2016). DOI: [10.1520/F1276-99R16](#); [10.1520/F1276-23](#).

² For referenced ASTM standards, visit the ASTM website, [www.astm.org](#), or contact ASTM Customer Service at [service@astm.org](#). For *Annual Book of ASTM Standards* volume information, refer to the standard's Document Summary page on the ASTM website.

³ Detailed working drawings of this apparatus are available from ASTM Headquarters, 100 Barr Harbor Drive, West Conshohocken, PA 19428–2959 USA. Order Adjunct No. 12-600-381-00.

and bolt. Run at room or elevated temperatures, the stress is determined by measuring the change in length of the calibrated bolt with a dial indicator. The bolt length is measured at the beginning of the test and at the end of the test. The percent relaxation is calculated from this.

4. Significance and Use

4.1 This test method is designed to compare related materials under controlled conditions and their ability to maintain a given compressive stress as a function of time. A portion of the torque loss on the bolted flange is a result of creep relaxation. Torque loss can also be caused by elongation of the bolts, distortion of the flanges, and vibration; therefore, the results obtained should be correlated with field results. This test method may be used as a routine test when agreed upon between the user and the producer.

5. Apparatus

5.1 *Relaxometer*,⁴ composed of two platens, special drilled and calibrated bolt, washer and nut composed of Specification **A193/A193M** Grade B7 or Specification **B637** Grade UNS N07718, or other alloys of construction that would satisfy the calibration Procedure (see Annex) for the test temperature specified and a dial indicator assembly as shown in **Fig. 1**.

5.2 *Box End Wrench*.

5.3 *Steel Blanking Die*.

6. Test Specimens

6.1 Specimen size shall be 10.16 ± 0.381 mm (0.400 ± 0.015 in.) wide by 31.75 ± 0.381 mm (1.250 ± 0.015 in.) long.

6.2 Four specimens are required per test.

6.3 A minimum of three tests shall be conducted.

6.4 Nominal thickness of specimens shall be that of the laminated composite gasket.

7. Conditioning

7.1 When all nonmetallic layers of the laminated composite are the same type, condition in accordance with that type as shown in **Table 1**.

7.2 When the nonmetallic layers of the laminated composite are of different types, the specimen shall be conditioned for 22 h in a controlled-humidity room or in a closed chamber of air at 21 to 30°C (70 to 85°F) and 50 to 55 % relative humidity. In all cases where testing is conducted outside the area of specified humidity, specimens shall be removed from the chamber one at a time as needed.

7.3 Other conditioning may be as agreed upon between the producer and the user.

8. Procedure

8.1 Clean all surfaces and lightly lubricate the washer and bolt threads; graphite and molybdenum disulfide have been found to be acceptable lubricants.

8.2 Place the specimens between the platens in accordance with **Fig. 1** making sure they are no closer than 2 mm (0.078 in) to the other pieces and the edge of the platens.

8.3 Place the washer in position and screw on the nut, finger tight.

⁴ Dario P. Bernasconi, 40 Farrington St., Stoughton, MA 02072, and Donald G. Johnson, Metal Samples, P.O. Box 8, Munford, AL 36268, are suppliers of the relaxometer.

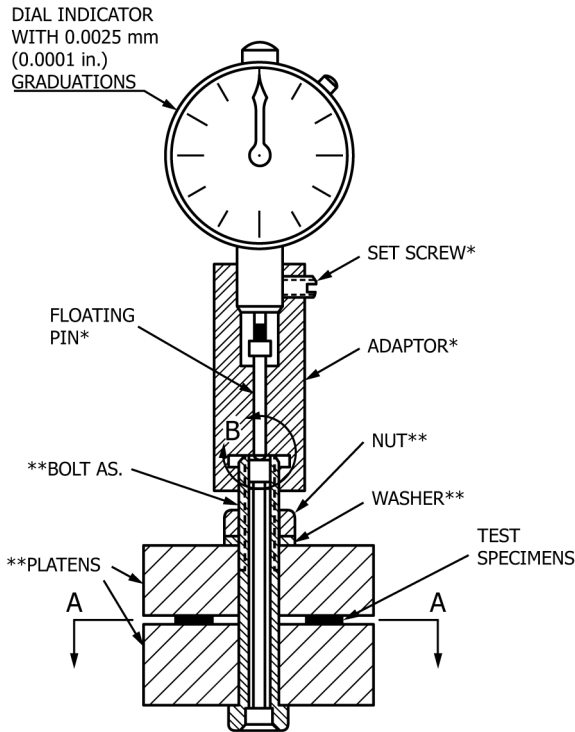

*PARTS REFERRED TO AS DIAL INDICATOR ASSEMBLY

**PARTS REFERRED TO AS RELAXOMETER

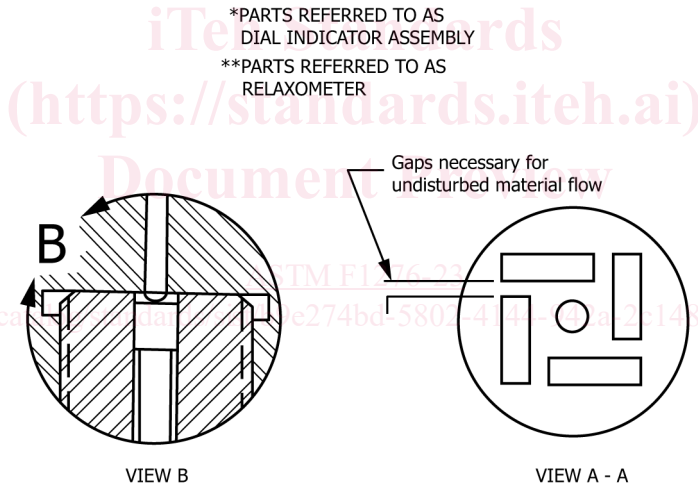

FIG. 1 Relaxometer and Dial Indicator Assembly

8.4 Screw on the dial indicator assembly, finger tight, and set the dial indicator at the zero reading.

8.5 Apply stress to the specimens by tightening the nut with a wrench until the desired dial indicator reading is reached; record the reading (D_o). Apply the stress in one continuous motion with a maximum loading time of 3 s. A bolt elongation of 0.1222 to 0.1270 mm (0.00481 to 0.00500 in.) is typical for a compressive force of 26.7 kN (6000 lbf). Remove the dial indicator assembly. (The calibration procedure is outlined in Annex A1.)

NOTE 1—When testing materials thicker than 0.8 mm (0.03 in.), the time to tighten the nut may be extended to 5 s maximum to allow for the longer arc required to apply the test load.

8.6 Place the specimen unit in a hot air-circulating oven for 22 h at $100 \pm 2^\circ\text{C}$ ($212 \pm 3.6^\circ\text{F}$), unless otherwise specified. The maximum test temperature for Specification A193/A193M Grade B7 shall not exceed 204°C (400°F). The maximum test temperature for Grade UNS N07718 shall not exceed 482°C (900°F).

TABLE 1 Test Method for Creep Relaxation of Laminated Composite Materials Conditioning for Laminated Composite Gasket Materials

Type of Gasket Material in the Nonmetallic Layers	Classification	
	Identification	Conditioning Procedure
	F104	
	First Two Numerals of Six-Digit Number	
Compressed asbestos sheet; asbestos beater sheet; flexible graphite	F11, F12, F51, F52	1 h at 100 ± 2°C (212 ± 3.6°F) Cool in desiccator over anhydrous calcium chloride 21 to 30°C (70 to 85°F)
Asbestos paper and millboard	F13	4 h at 100 ± 2°C (212 ± 3.6°F) Cool as in Procedure A of Classification F104
Cork composition Cork and cellular rubber	F21, F23	At least 46 h at 21 to 30°C (70 to 85°F) and 50 to 55 % relative humidity
Cork and rubber	F22	At least 46 h at 21 to 30°C (70 to 85°F) and 50 to 55 % relative humidity
Treated and untreated papers from cellulose or other organic fibers	F31, F32, F33, F34	4 h at 21 to 30°C (70 to 85°F) over anhydrous calcium chloride followed immediately by at least 20 h at 21 to 30°C (70 to 85°F) and 50 to 55 % relative humidity
Compressed nonasbestos sheet; nonasbestos beater sheet	F71, F72	1 h at 100 ± 2°C (212 ± 3.6°F) Cool in desiccator over anhydrous calcium chloride 21 to 30°C (70 to 85°F)
Nonasbestos paper and millboard	F73	4 h at 100 ± 2°C (212 ± 3.6°F) Cool as in Procedure A of Classification F104

TABLE 2 Precision and Bias Data

FORMAT A Precision of Creep Relaxation Test of Laminated Composite Gasket Materials Using Coefficient of Variation Method of Presenting Results on a Percentage Basis

NOTE 1— S = standard deviation, CV = % coefficient of variation = $(S \times 100)/(\text{average})$, LSD = % least significant difference between two individual test results, and based on a 95 % confidence level = $2\sqrt{2}(CV)$.

Material	Relaxation Values, % Average	Repeatability (Within Laboratories)			Reproducibility (Between Laboratories)		
		S	CV , %	LSD , %	S	CV , %	LSD , %
A	25.4	2.01	7.92	22.4	2.49	12.6	35.6
B	8.05	0.90	11.2	31.6	1.70	23.9	67.6
C	23.9	1.85	7.73	21.9	1.08	8.95	25.3
D	20.5	1.11	5.44	15.4	1.15	7.84	22.2
E	30.5	1.52	4.98	14.1	2.93	10.8	30.6
F	29.0	0.87	3.01	8.5	1.32	5.46	15.4

FORMAT B Precision and Bias Table for Creep Relaxation of Laminated Composite Gasket Materials Based on Actual Units of Measure

Note— S = standard deviation, CV = coefficient of variation = $(S)/(\text{average})$, LSD = least significant difference between two individual test results, and based on a 95 % confidence level = $2.8(S)$.

Table Mat	Range	Average	Repeatability			Reproducibility		
			S	CV	LSD	S	CV	LSD
A	19.57–31.85	25.44	2.01	0.079	5.63	2.49	0.098	6.97
B	4.78–11.02	8.05	0.90	0.112	2.52	1.70	0.211	4.76
C	18.24–29.74	23.91	1.85	0.077	5.18	1.08	0.045	3.02
D	16.80–24.59	20.47	1.11	0.054	3.11	1.15	0.056	3.22
E	23.33–38.64	30.51	1.52	0.050	4.26	2.93	0.096	8.20
F	24.69–32.44	29.00	0.87	0.030	2.44	1.32	0.046	3.70

8.7 Remove from the oven and cool to room temperature.

8.8 Replace the dial indicator assembly, finger tight, and set the dial indicator at the zero reading. Loosen the nut, without disturbing the dial indicator assembly, and record the dial reading (D_p).

8.9 Calculate the percent relaxation as follows:

$$\text{relaxation, \%} = [(D_o - D_f)/D_o] \times 100 \quad (1)$$

9. Report

9.1 Report the following information:

9.1.1 Identification and designation number of the material tested,

9.1.2 Test temperature,

9.1.3 Length of the test, in hours,

9.1.4 “Initial stress” used and the specimen thickness,

9.1.5 Percent stress loss for each specimen, and

9.1.6 Average of all the results recorded in 9.1.5.

10. Precision and Bias⁵

10.1 **Table 2** is based on a round robin test conducted in 1987 in accordance with Practice **E691**, involving six materials tested by five laboratories. For each material, the samples were blanked at two independent sources. Data analysis detected a statistically significant difference in the results obtained for each blanking source. This difference biases the results by adding variation but reflects a realistic test situation.

10.1.1 Each test result was the average of three individual determinations. Each laboratory obtained two test results for each material, a test result on material from Blanking Source 1, and a test result on material from Blanking Source 2.

10.2 Five laboratories tested the following six laminated composite gasket materials (Classifications **F868** and **F104** material designations) for creep relaxation:

<u>ASTM F1276-23</u>	
https://standards.iteh.ai/catalog/standards/sist/b9e274bd-5802-4144-942a-2c1487697706/stm-f1276-23	
	Material
9FMF1 (F = Type 1, Class 1)	A
9FMF1 (F = Type 5, Class 1)	B
9FMF2 (F = Type 1, Class 2)	C
9FMF2 (F = Type 7, Class 2)	D
9FMF1 (F = Type 1, Class 2)	E
9FMF1 (F = Type 7, Class 2)	F

10.2.1 **Table 2** conditioning was used by all laboratories. Test specimens were prepared from laminated composite gasket sheets by cutting them to size with a steel blanking die. Tests were conducted in accordance with this test method, with an initial stress of 20.68 MPa (3000 psi) applied on a 1290 mm² (2 in.²) sample area, total of 26.7 kN (6000 lb) compressive force. The tests were conducted for 22 h at 100°C (212°F). The test was conducted in triplicate on each material.

10.3 The precision results are given in **Table 2**.

11. Keywords

11.1 creep relaxation; deflection; gasket material; platens; relaxometer; strain; stress; temperature; torque bolt; torque loss

⁵ Supporting data have been filed at ASTM International Headquarters and may be obtained by requesting Research Report RR:F03-1012.